

STATE OF NORTH CAROLINA
DEPARTMENT OF TRANSPORTATION
RALEIGH, N.C.

C203844

CONTRACT AND
CONTRACT BONDS

FOR CONTRACT NO. C203844

WBS 34900.3.5 STATE FUNDED

T.I.P NO. U-3109A

COUNTY OF ALAMANCE

THIS IS THE ROADWAY & STRUCTURE CONTRACT

ROUTE NUMBER NC 119 LENGTH 3.457 MILES

LOCATION NC-119 RELOCATION FROM I-40/85 TO SR-1921 (MEBANE ROGERS RD/
STAGE COACH RD).

CONTRACTOR THALLE CONSTRUCTION CO., INC.

ADDRESS 900 NC 86 NORTH
HILLSBOROUGH, NC 27278

BIDS OPENED MAY 16, 2017

CONTRACT EXECUTION 6/15/2017

STATE OF NORTH CAROLINA
DEPARTMENT OF TRANSPORTATION
RALEIGH, N.C.

PROPOSAL

INCLUDES ADDENDUM No. 1 DATED 05-10-2017

DATE AND TIME OF BID OPENING: **MAY 16, 2017 AT 2:00 PM**

CONTRACT ID C203844
WBS 34900.3.5

FEDERAL-AID NO. STATE FUNDED

COUNTY ALAMANCE

T.I.P. NO. U-3109A

MILES 3.457

ROUTE NO. NC 119

LOCATION NC-119 RELOCATION FROM I-40/85 TO SR-1921 (MEBANE ROGERS RD/
STAGE COACH RD).

TYPE OF WORK GRADING, DRAINAGE, PAVING, SIGNALS & STRUCTURES.

NOTICE:

ALL BIDDERS SHALL COMPLY WITH ALL APPLICABLE LAWS REGULATING THE PRACTICE OF GENERAL CONTRACTING AS CONTAINED IN CHAPTER 87 OF THE GENERAL STATUTES OF NORTH CAROLINA WHICH REQUIRES THE BIDDER TO BE LICENSED BY THE N.C. LICENSING BOARD FOR CONTRACTORS WHEN BIDDING ON ANY NON-FEDERAL AID PROJECT WHERE THE BID IS \$30,000 OR MORE, EXCEPT FOR CERTAIN SPECIALTY WORK AS DETERMINED BY THE LICENSING BOARD. BIDDERS SHALL ALSO COMPLY WITH ALL OTHER APPLICABLE LAWS REGULATING THE PRACTICES OF ELECTRICAL, PLUMBING, HEATING AND AIR CONDITIONING AND REFRIGERATION CONTRACTING AS CONTAINED IN CHAPTER 87 OF THE GENERAL STATUTES OF NORTH CAROLINA. NOTWITHSTANDING THESE LIMITATIONS ON BIDDING, THE BIDDER WHO IS AWARDED ANY FEDERAL - AID FUNDED PROJECT SHALL COMPLY WITH CHAPTER 87 OF THE GENERAL STATUTES OF NORTH CAROLINA FOR LICENSING REQUIREMENTS WITHIN 60 CALENDAR DAYS OF BID OPENING.

BIDS WILL BE RECEIVED AS SHOWN BELOW:

THIS IS A ROADWAY & STRUCTURE PROPOSAL

5% BID BOND OR BID DEPOSIT REQUIRED

**PROPOSAL FOR THE CONSTRUCTION OF
CONTRACT No. C203844 IN ALAMANCE COUNTY, NORTH CAROLINA**

Date _____ 20 _____

**DEPARTMENT OF TRANSPORTATION,
RALEIGH, NORTH CAROLINA**

The Bidder has carefully examined the location of the proposed work to be known as Contract No. C203844 has carefully examined the plans and specifications, which are acknowledged to be part of the proposal, the special provisions, the proposal, the form of contract, and the forms of contract payment bond and contract performance bond; and thoroughly understands the stipulations, requirements and provisions. The undersigned bidder agrees to bound upon his execution of the bid and subsequent award to him by the Board of Transportation in accordance with this proposal to provide the necessary contract payment bond and contract performance bond within fourteen days after the written notice of award is received by him. The undersigned Bidder further agrees to provide all necessary machinery, tools, labor, and other means of construction; and to do all the work and to furnish all materials, except as otherwise noted, necessary to perform and complete the said contract in accordance with *the 2012 Standard Specifications for Roads and Structures* by the dates(s) specified in the Project Special Provisions and in accordance with the requirements of the Engineer, and at the unit or lump sum prices, as the case may be, for the various items given on the sheets contained herein.

The Bidder shall provide and furnish all the materials, machinery, implements, appliances and tools, and perform the work and required labor to construct and complete State Highway Contract No. C203844 in Alamance County, for the unit or lump sum prices, as the case may be, bid by the Bidder in his bid and according to the proposal, plans, and specifications prepared by said Department, which proposal, plans, and specifications show the details covering this project, and hereby become a part of this contract.

The published volume entitled *North Carolina Department of Transportation, Raleigh, Standard Specifications for Roads and Structures, January 2012* with all amendments and supplements thereto, is by reference incorporated into and made a part of this contract; that, except as herein modified, all the construction and work included in this contract is to be done in accordance with the specifications contained in said volume, and amendments and supplements thereto, under the direction of the Engineer.

If the proposal is accepted and the award is made, the contract is valid only when signed either by the Contract Officer or such other person as may be designated by the Secretary to sign for the Department of Transportation. The conditions and provisions herein cannot be changed except over the signature of the said Contract Officer.

The quantities shown in the itemized proposal for the project are considered to be approximate only and are given as the basis for comparison of bids. The Department of Transportation may increase or decrease the quantity of any item or portion of the work as may be deemed necessary or expedient.

An increase or decrease in the quantity of an item will not be regarded as sufficient ground for an increase or decrease in the unit prices, nor in the time allowed for the completion of the work, except as provided for the contract.

Accompanying this bid is a bid bond secured by a corporate surety, or certified check payable to the order of the Department of Transportation, for five percent of the total bid price, which deposit is to be forfeited as liquidated damages in case this bid is accepted and the Bidder shall fail to provide the required payment and performance bonds with the Department of Transportation, under the condition of this proposal, within 14 calendar days after the written notice of award is received by him, as provided in the *Standard Specifications*; otherwise said deposit will be returned to the Bidder.



State Contract Officer

DocuSigned by:
Ronald Elton Davenport, Jr.
F81B6038A47A442...

5/10/2017

TABLE OF CONTENTS

COVER SHEET PROPOSAL SHEET

PROJECT SPECIAL PROVISIONS

| | |
|---|------|
| CONTRACT TIME AND LIQUIDATED DAMAGES: | G-1 |
| INTERMEDIATE CONTRACT TIME NUMBER 1 AND LIQUIDATED DAMAGES: | G-1 |
| INTERMEDIATE CONTRACT TIME NUMBER 2 AND LIQUIDATED DAMAGES: | G-2 |
| INTERMEDIATE CONTRACT TIME NUMBER 3 AND LIQUIDATED DAMAGES: | G-3 |
| INTERMEDIATE CONTRACT TIME NUMBER 4 AND LIQUIDATED DAMAGES: | G-4 |
| INTERMEDIATE CONTRACT TIME NUMBER 5, INCENTIVE/DISINCENTIVE, AND BONUS CLAUSE: | G-4 |
| INTERMEDIATE CONTRACT TIME NUMBER 6 AND LIQUIDATED DAMAGES: | G-5 |
| INTERMEDIATE CONTRACT TIME NUMBER 7 AND LIQUIDATED DAMAGES: | G-5 |
| INTERMEDIATE CONTRACT TIME NUMBER 8 AND LIQUIDATED DAMAGES: | G-6 |
| INTERMEDIATE CONTRACT TIME NUMBER 9 AND LIQUIDATED DAMAGES: | G-6 |
| INTERMEDIATE CONTRACT TIME NUMBER 10 AND LIQUIDATED DAMAGES: | G-6 |
| INTERMEDIATE CONTRACT TIME NUMBER 11 AND LIQUIDATED DAMAGES: | G-6 |
| PERMANENT VEGETATION ESTABLISHMENT:..... | G-7 |
| DELAY IN RIGHT OF ENTRY: | G-7 |
| MAJOR CONTRACT ITEMS: | G-8 |
| SPECIALTY ITEMS:..... | G-8 |
| FUEL PRICE ADJUSTMENT:..... | G-8 |
| PAYOUT SCHEDULE: | G-9 |
| SCHEDULE OF ESTIMATED COMPLETION PROGRESS:..... | G-9 |
| MINORITY BUSINESS ENTERPRISE AND WOMEN BUSINESS ENTERPRISE: | G-9 |
| CONTRACTOR'S LICENSE REQUIREMENTS: | G-24 |
| SUBSURFACE INFORMATION:..... | G-24 |
| LOCATING EXISTING UNDERGROUND UTILITIES:..... | G-24 |
| VALUE ENGINEERING PROPOSAL: | G-24 |
| RESOURCE CONSERVATION AND ENV. SUSTAINABLE PRACTICES:..... | G-25 |
| DOMESTIC STEEL: | G-26 |
| PORTABLE CONCRETE BARRIER - (Partial Payments for Materials):..... | G-26 |
| REMOVABLE PAVEMENT MARKINGS - (Partial Payments for Materials):..... | G-27 |
| MAINTENANCE OF THE PROJECT: | G-27 |
| BID DOCUMENTATION: | G-28 |
| TWELVE MONTH GUARANTEE: | G-31 |
| OUTSOURCING OUTSIDE THE USA: | G-31 |
| IRAN DIVESTMENT ACT: | G-32 |
| GIFTS FROM VENDORS AND CONTRACTORS: | G-32 |
| LIABILITY INSURANCE:..... | G-33 |
| EROSION AND SEDIMENT CONTROL/STORMWATER CERTIFICATION: | G-33 |
| PROCEDURE FOR MONITORING BORROW PIT DISCHARGE:..... | G-38 |
| EMPLOYMENT:..... | G-39 |
| STATE HIGHWAY ADMINISTRATOR TITLE CHANGE:..... | G-40 |
| SUBLETTING OF CONTRACT: | G-40 |
| RECEIPT OF PERMITS: | G-40 |

ROADWAY..... R-1

STANDARD SPECIAL PROVISIONS

AVAILABILITY FUNDS – TERMINATION OF CONTRACTS SSP-1
 NCDOT GENERAL SEED SPECIFICATION FOR SEED QUALITY SSP-2
 ERRATA..... SSP-5
 PLANT AND PEST QUARANTINES SSP-7
 MINIMUM WAGES SSP-8
 AWARD OF CONTRACT..... SSP-9
 ON-THE-JOB TRAINING SSP-14
 NCDENR NAME CHANGE..... SSP-17

UNIT PROJECT SPECIAL PROVISIONS

GEOTECHNICAL.....GT-0.1
 GEOENVIRONMENTAL..... GV-1
 SIGNING SN-1
 TRAFFIC CONTROL TC-1
 UTILITY CONSTRUCTION UC-1
 UTILITY BY OTHERSUBO-1
 EROSION CONTROLEC-1
 TRAFFIC SIGNALS TS-1
 STRUCTURE / CULVERTS..... ST-1
 CULVERTS C-1

PROPOSAL ITEM SHEET

ITEM SHEET(S) (TAN SHEETS)

PROJECT SPECIAL PROVISIONS**GENERAL****CONTRACT TIME AND LIQUIDATED DAMAGES:**

(8-15-00) (Rev. 12-18-07)

108

SP1 G07 A

The date of availability for this contract is **June 26, 2017**, except that work in jurisdictional waters and wetlands shall not begin until a meeting between the DOT, Regulatory Agencies, and the Contractor is held as stipulated in the permits contained elsewhere in this proposal. This delay in availability has been considered in determining the contract time for this project.

The completion date for this contract is **January 28, 2021**.

Except where otherwise provided by the contract, observation periods required by the contract will not be a part of the work to be completed by the completion date and/or intermediate contract times stated in the contract. The acceptable completion of the observation periods that extend beyond the final completion date shall be a part of the work covered by the performance and payment bonds.

The liquidated damages for this contract are **Two Hundred Dollars (\$ 200.00)** per calendar day. These liquidated damages will not be cumulative with any liquidated damages which may become chargeable under Intermediate Contract Time Number 1.

INTERMEDIATE CONTRACT TIME NUMBER 1 AND LIQUIDATED DAMAGES:

(7-1-95) (Rev. 2-21-12)

108

SP1 G13 A

Except for that work required under the Project Special Provisions entitled *Planting, Reforestation* and/or *Permanent Vegetation Establishment*, included elsewhere in this proposal, the Contractor will be required to complete all work included in this contract and shall place and maintain traffic on same.

The date of availability for this intermediate contract time is **June 26, 2017**.

The completion date for this intermediate contract time is **August 1, 2020**.

The liquidated damages for this intermediate contract time are **Three Thousand Dollars (\$ 3,000.00)** per calendar day.

Upon apparent completion of all the work required to be completed by this intermediate date, a final inspection will be held in accordance with Article 105-17 and upon acceptance, the Department will assume responsibility for the maintenance of all work except *Planting, Reforestation* and/or *Permanent Vegetation Establishment*. The Contractor will be responsible for and shall make corrections of all damages to the completed roadway caused by his planting operations, whether occurring prior to or after placing traffic through the project.

INTERMEDIATE CONTRACT TIME NUMBER 2 AND LIQUIDATED DAMAGES:

(2-20-07)

108

SP1 G14 A

The Contractor shall complete the required work of installing, maintaining, and removing the traffic control devices for lane closures and restoring traffic to the existing traffic pattern. The Contractor shall not close or narrow a lane of traffic on **I-85 and All I-85 Ramps** during the following time restrictions:

DAY AND TIME RESTRICTIONS

| | | |
|----------------------------|--------------------------|----------------------|
| I-85 (1 of 4 Lanes) | 6:00AM to 8:00PM | Monday-Sunday |
| I-85 (2 of 4 Lanes) | 6:00AM to 10:00PM | Monday-Sunday |
| I-85 (3 of 4 Lanes) | 6:00AM to 1:00AM | Monday-Sunday |
| All I-85 Ramps | 6:00AM to 8:00PM | Monday-Sunday |

In addition, the Contractor shall not close or narrow a lane of traffic on **I-85 and All I-85 Ramps** detain and/or alter the traffic flow on or during holidays, holiday weekends, special events, or any other time when traffic is unusually heavy, including the following schedules:

HOLIDAY AND HOLIDAY WEEKEND LANE CLOSURE RESTRICTIONS

1. For any **unexpected occurrence** that creates unusually high traffic volumes, as directed by the Engineer.
2. For **New Year's Day**, between the hours of **6:00AM** December 31st and **8:00PM** January 2nd. If New Year's Day is on a Friday, Saturday, Sunday or Monday, then until **8:00PM** the following Tuesday.
3. For **Easter**, between the hours of **6:00AM** Thursday and **8:00PM** Monday.
4. For **Memorial Day**, between the hours of **6:00AM** Friday and **8:00PM** Tuesday.
5. For **Independence Day**, between the hours of **6:00AM** the day before Independence Day and **8:00PM** the day after Independence Day.

If **Independence Day** is on a Friday, Saturday, Sunday or Monday, then between the hours of **6:00AM** the Thursday before Independence Day and **8:00PM** the Tuesday after Independence Day.
6. For **Labor Day**, between the hours of **6:00AM** Friday and **8:00PM** Tuesday.
7. For **Thanksgiving**, between the hours of **6:00AM** Tuesday and **8:00PM** Monday.
8. For **Christmas**, between the hours of **6:00AM** the Friday before the week of Christmas Day and **8:00PM** the following Tuesday after the week of Christmas Day.
9. For **Football & Basketball Games at UNC in Chapel Hill**, between **five (5)** hours before the start and **five (5)** hours after the end of the **Football & Basketball Games at UNC in Chapel Hill**.

Holidays and holiday weekends shall include New Year's Day, Easter, Memorial Day, Independence Day, Labor Day, Thanksgiving, and Christmas. The Contractor shall schedule his work so that lane closures will not be required during these periods, unless otherwise directed by the Engineer.

The time of availability for this intermediate contract work shall be the time the Contractor begins to install all traffic control devices for lane closures according to the time restrictions listed herein.

The completion time for this intermediate contract work shall be the time the Contractor is required to complete the removal of all traffic control devices for lane closures according to the time restrictions stated above and place traffic in the existing traffic pattern.

The liquidated damages are **Two Thousand Five Hundred Dollars (\$ 2,500.00)** per fifteen (15) minute time period.

INTERMEDIATE CONTRACT TIME NUMBER 3 AND LIQUIDATED DAMAGES:

(2-20-07)

108

SP1 G14 C

The Contractor shall complete the required work of installing, maintaining and removing the traffic control devices for lane closures and restoring traffic to the existing traffic pattern. The Contractor shall not close or narrow a lane of traffic on **the following roads** during the following time restrictions:

DAY AND TIME RESTRICTIONS

| | | |
|-----------------------------|-------------------------------------|----------------------|
| -L,-Y2,-Y3,-Y6,-Y6A- | 6:00AM-9:00AM, 4:00PM-6:00PM | Monday-Friday |
| -Y5B,-Y5C,-Y7,-Y7A- | 6:00AM-9:00AM | Monday-Friday |
| -Y7B,-Y8,-Y9- | 6:00AM-9:00AM | Monday-Friday |
| -Y10,-Y16,-Y19,-Y20- | 6:00AM-9:00AM | Monday-Friday |

The time of availability for this intermediate contract time will be the time the Contractor begins to install traffic control devices required for the lane closures according to the time restrictions stated herein.

The completion time for this intermediate contract time will be the time the Contractor is required to complete the removal of traffic control devices required for the lane closures according to the time restrictions stated herein and restore traffic to the existing traffic pattern.

The liquidated damages are **Five Hundred Dollars (\$ 500.00)** per fifteen (15) minute time period.

INTERMEDIATE CONTRACT TIME NUMBER 4 AND LIQUIDATED DAMAGES:

(2-20-07)

108

SP1 G14 D

The Contractor shall complete the required work of installing, maintaining and removing the traffic control devices for road closures and restoring traffic to the existing traffic pattern. The Contractor shall not close **I-85, -Y16-, or -Y26-** during the following time restrictions:

DAY AND TIME RESTRICTIONS

| | | |
|--------------|----------------------------------|----------------------|
| I-85 | 6:00AM-1:00AM | Monday-Sunday |
| -Y16- | 6:00AM-12:00AM (Midnight) | Monday-Sunday |
| -Y26- | 6:00AM-12:00AM (Midnight) | Monday-Sunday |

The time of availability for this intermediate contract time will be the time the Contractor begins to install traffic control devices required for road closures according to the time restrictions stated herein.

The completion time for this intermediate contract time will be the time the Contractor is required to complete the removal of traffic control devices required for the road closures according to the time restrictions stated herein and restore traffic to the existing traffic pattern

The liquidated damages are **Two Thousand Five Hundred Dollars (\$ 2,500.00)** per fifteen (15) minute time period.

INTERMEDIATE CONTRACT TIME NUMBER 5, INCENTIVE/DISINCENTIVE, AND BONUS CLAUSE:

The Contractor shall complete all work required of **Phase II, Step #5** as shown on Sheet **TMP-3A** and shall place and maintain traffic **in the diverging diamond interchange traffic pattern**.

The date of availability for this intermediate contract time is **June 26, 2017**.

The completion date for this intermediate contract time is the date which is **four hundred twenty (420)** consecutive calendar days after and including the date of availability.

It is mutually agreed that time is of the essence in completing Intermediate Contract Time Number 5 and opening same to traffic. It is further mutually agreed a delay in completing this work will result in damage due to increased engineering and inspection costs to the Department, great hardship to the general public, public inconvenience, and obstruction of traffic, interference with business and increased cost of maintaining traffic.

By reason of the necessity of expeditious completion of the work included in Intermediate Contract Time Number 5 and placing and maintaining traffic on same, it is mutually agreed the Contractor shall receive an incentive payment of **Two Thousand Five Hundred Dollars (\$2,500.00)** per calendar day for each day prior to the completion date established for Intermediate Contract Time Number 5 that this work is completed. Incentive payment shall be limited to a maximum of **Three Hundred Thousand Dollars (\$300,000.00)**. No incentive payment shall be allowed for any calendar day after the completion date established for Intermediate Contract Time

Number 5 that this work remains incomplete. **This date shall be utilized in determining incentive payments and it shall not be revised for any reason whatsoever.** Incentive payment determined to be due the Contractor, shall be paid by the Department within **forty-five (45)** calendar days after completion of all the work. No incentive payment shall be allowed if the contract is terminated under the provisions of Article 108.13.

Disincentive of **Two Thousand Five Hundred Dollars (\$2,500.00)** per calendar day shall be assessed the Contractor for each day beyond the completion date established for Intermediate Contract Time Number 5 that the work is not completed.

In addition to the above time limit, the Department desires that Intermediate Contract Time Number 5 be completed by the date which is **three hundred (300)** consecutive calendar days after the date of availability, and that the Contractor pursue the work with such labor, equipment and materials as necessary to ensure that the completion date will be met without regard to time extensions and time reliefs provided for in the specifications. **This date shall be utilized in determining Bonus payment and it shall not be revised for any reason whatsoever.** Therefore, as full compensation for all extra costs involved, the Department agrees to pay as a bonus, in addition to the aforementioned daily incentive payments for early completion, the sum of **Two Hundred Thousand Dollars (\$200,000.00)** to the Contractor for satisfactorily completing Intermediate Contract Time Number 5 on or prior to the date which is **three hundred (300)** consecutive calendar days after the date of availability. Should the Contractor fail to complete Intermediate Contract Time Number 5 by this date, no bonus will be allowed.

INTERMEDIATE CONTRACT TIME NUMBER 6 AND LIQUIDATED DAMAGES:

(2-20-07) (Rev. 6-18-13)

108

SP1 G14 H

The Contractor shall complete the work required of **Phase II, Steps #6A & #6B** as shown on Sheet **TMP-3A** and shall place and maintain traffic on same.

The date of availability for this intermediate contract time is **June 26, 2017**.

The completion date for this intermediate contract time is the date which is **five hundred fifty (550)** consecutive calendar days after and including the date the Contractor begins this work.

The liquidated damages are **One Thousand Dollars (\$ 1,000.00)** per calendar day.

INTERMEDIATE CONTRACT TIME NUMBER 7 AND LIQUIDATED DAMAGES:

(2-20-07) (Rev. 6-18-13)

108

SP1 G14 H

The Contractor shall complete the work required of **Phase I, Steps #2A thru #2F** as shown on Sheet **TMP-3** and shall place and maintain traffic on same.

The date of availability for this intermediate contract time is the date the Contractor elects to begin the work.

The completion date for this intermediate contract time is the date which is **Sixty (60)** consecutive calendar days after and including the date the Contractor begins this work.

The liquidated damages are **One Thousand Dollars (\$ 1,000.00)** per calendar day.

INTERMEDIATE CONTRACT TIME NUMBER 8 AND LIQUIDATED DAMAGES:

(2-20-07) (Rev. 6-18-13)

108

SPI G14 H

The Contractor shall complete the work required of **Phase I, Steps #4C thru #4G** as shown on Sheet **TMP-3** and shall place and maintain traffic on same.

The date of availability for this intermediate contract time is the date the Contractor elects to begin the work.

The completion date for this intermediate contract time is the date which is **Sixty (60)** consecutive calendar days after and including the date the Contractor begins this work.

The liquidated damages are **Five Hundred Dollars (\$ 500.00)** per calendar day.

INTERMEDIATE CONTRACT TIME NUMBER 9 AND LIQUIDATED DAMAGES:

(2-20-07) (Rev. 6-18-13)

108

SPI G14 F

The Contractor shall complete the work required of **Phase I, Steps #4F and #4G** as shown on Sheet **TMP-3** and shall place and maintain traffic on same.

The time of availability for this intermediate contract time is the **Friday** at **7:00PM** that the Contractor elects to begin the work.

The completion time for this intermediate contract time is the following **Monday** at **6:00AM** after the time of availability.

The liquidated damages are **One Thousand Dollars (\$ 1,000.00)** per fifteen (15) minute time period.

INTERMEDIATE CONTRACT TIME NUMBER 10 AND LIQUIDATED DAMAGES:

(2-20-07) (Rev. 6-18-13)

108

SPI G14 H

The Contractor shall complete the work required of **Phase II, Steps #4 and #5** as shown on Sheet **TMP-3A** and shall place and maintain traffic on same.

The time of availability for this intermediate contract time is the **Friday** at **9:00PM** that the Contractor elects to begin the work.

The completion time for this intermediate contract time is the following **Monday** at **6:00AM** after the time of availability.

The liquidated damages are **One Thousand Dollars (\$ 1,000.00)** per fifteen (15) minute time period.

INTERMEDIATE CONTRACT TIME NUMBER 11 AND LIQUIDATED DAMAGES:

(2-20-07) (Rev. 6-18-13)

108

SPI G14 H

The Contractor shall complete the work required of **Phase III, Step #1D** as shown on Sheet **TMP-3A** and shall place and maintain traffic on same.

The date of availability for this intermediate contract time is the date the Contractor elects to begin the work.

The completion date for this intermediate contract time is the date which is **Seven (7)** consecutive calendar days after and including the date the Contractor begins this work.

The liquidated damages are **One Thousand Dollars (\$ 1,000.00)** per calendar day.

PERMANENT VEGETATION ESTABLISHMENT:

(2-16-12) (Rev. 10-15-13)

104

SP1 G16

Establish a permanent stand of the vegetation mixture shown in the contract. During the period between initial vegetation planting and final project acceptance, perform all work necessary to establish permanent vegetation on all erodible areas within the project limits, as well as, in borrow and waste pits. This work shall include erosion control device maintenance and installation, repair seeding and mulching, supplemental seeding and mulching, mowing, and fertilizer topdressing, as directed. All work shall be performed in accordance with the applicable section of the *2012 Standard Specifications*. All work required for initial vegetation planting shall be performed as a part of the work necessary for the completion and acceptance of the Intermediate Contract Time (ICT). Between the time of ICT and Final Project acceptance, or otherwise referred to as the vegetation establishment period, the Department will be responsible for preparing the required National Pollutant Discharge Elimination System (NPDES) inspection records.

Once the Engineer has determined that the permanent vegetation establishment requirement has been achieved at an 80% vegetation density (the amount of established vegetation per given area to stabilize the soil) and no erodible areas exist within the project limits, the Contractor will be notified to remove the remaining erosion control devices that are no longer needed. The Contractor will be responsible for, and shall correct any areas disturbed by operations performed in permanent vegetation establishment and the removal of temporary erosion control measures, whether occurring prior to or after placing traffic on the project.

Payment for *Response for Erosion Control, Seeding and Mulching, Repair Seeding, Supplemental Seeding, Mowing, Fertilizer Topdressing, Silt Excavation, and Stone for Erosion Control* will be made at contract unit prices for the affected items. Work required that is not represented by contract line items will be paid in accordance with Articles 104-7 or 104-3 of the *2012 Standard Specifications*. No additional compensation will be made for maintenance and removal of temporary erosion control items.

DELAY IN RIGHT OF ENTRY:

(7-1-95) (Rev. 7-15-14)

108

SP1 G22

The Contractor will not be allowed right of entry to the following parcel(s) prior to the listed date(s) unless otherwise permitted by the Engineer.

| <u>Parcel No.</u> | <u>Property Owner</u> | <u>Date</u> |
|--------------------------|------------------------------|--------------------|
| 180 | United States Postal Service | June 2, 2017 |

MAJOR CONTRACT ITEMS:

(2-19-02)

104

SP1 G28

The following listed items are the major contract items for this contract (see Article 104-5 of the 2012 *Standard Specifications*):

| Line # | Description |
|---------------|-------------------------------|
| 6 | Unclassified Excavation |
| 9 | Borrow Excavation |
| 337 | Reinforced Concrete Deck Slab |

SPECIALTY ITEMS:

(7-1-95)(Rev. 1-17-12)

108-6

SP1 G37

Items listed below will be the specialty items for this contract (see Article 108-6 of the 2012 *Standard Specifications*).

| Line # | Description |
|------------------|-----------------------------|
| 128-139 | Guardrail |
| 140-148 | Fencing |
| 154-171 | Signing |
| 194-204, 206-207 | Long-Life Pavement Markings |
| 205 | Removable Tape |
| 220-221 | Permanent Pavement Markers |
| 223-229 | Utility Construction |
| 230-265, 268 | Erosion Control |
| 266-267 | Reforestation |
| 269-314, 356 | Signals/ITS System |
| 331-336 | Drilled Piers |

FUEL PRICE ADJUSTMENT:

(11-15-05) (Rev. 2-18-14)

109-8

SP1 G43

Revise the 2012 *Standard Specifications* as follows:

Page 1-83, Article 109-8, Fuel Price Adjustments, add the following:

The base index price for DIESEL #2 FUEL is \$ **1.5765** per gallon. Where any of the following are included as pay items in the contract, they will be eligible for fuel price adjustment.

The pay items and the fuel factor used in calculating adjustments to be made will be as follows:

| Description | Units | Fuel Usage Factor Diesel |
|---|--------------|---------------------------------|
| Unclassified Excavation | Gal/CY | 0.29 |
| Borrow Excavation | Gal/CY | 0.29 |
| Class IV Subgrade Stabilization | Gal/Ton | 0.55 |
| Aggregate Base Course | Gal/Ton | 0.55 |
| Sub-Ballast | Gal/Ton | 0.55 |
| Asphalt Concrete Base Course, Type ____ | Gal/Ton | 2.90 |

| | | |
|---|---------|-------|
| Asphalt Concrete Intermediate Course, Type ____ | Gal/Ton | 2.90 |
| Asphalt Concrete Surface Course, Type ____ | Gal/Ton | 2.90 |
| Open-Graded Asphalt Friction Course | Gal/Ton | 2.90 |
| Permeable Asphalt Drainage Course, Type ____ | Gal/Ton | 2.90 |
| Sand Asphalt Surface Course, Type ____ | Gal/Ton | 2.90 |
| Aggregate for Cement Treated Base Course | Gal/Ton | 0.55 |
| Portland Cement for Cement Treated Base Course | Gal/Ton | 0.55 |
| __" Portland Cement Concrete Pavement | Gal/SY | 0.245 |
| Concrete Shoulders Adjacent to __" Pavement | Gal/SY | 0.245 |

PAYOUT SCHEDULE:

(1-19-10) (Rev. 1-17-12)

108

SP1 G57

Submit an Anticipated Monthly Payout Schedule prior to beginning construction. The Anticipated Monthly Payout Schedule will be used by the Department to monitor funding levels for this project. Include a monthly percentage breakdown (in terms of the total contract amount) of the work anticipated to be completed. The schedule should begin with the date the Contractor plans to begin construction and end with the anticipated completion date. Submit updates of the Anticipated Monthly Payout Schedule on March 15, June 15, September 15, and December 15 of each calendar year until project acceptance. Submit the original Anticipated Monthly Payout Schedule and all subsequent updates to the Resident Engineer with a copy to the State Construction Engineer at 1 South Wilmington Street, 1543 Mail Service Center, Raleigh, NC 27699-1543.

SCHEDULE OF ESTIMATED COMPLETION PROGRESS:

(7-15-08) (Rev. 5-17-16)

108-2

SP1 G58

The Contractor's attention is directed to the Standard Special Provision entitled *Availability of Funds Termination of Contracts* included elsewhere in this proposal. The Department of Transportation's schedule of estimated completion progress for this project as required by that Standard Special Provision is as follows:

| | <u>Fiscal Year</u> | <u>Progress (% of Dollar Value)</u> |
|------|---------------------------|--|
| 2018 | (7/01/17 - 6/30/18) | 44% of Total Amount Bid |
| 2019 | (7/01/18 - 6/30/19) | 34% of Total Amount Bid |
| 2020 | (7/01/19 - 6/30/20) | 21% of Total Amount Bid |
| 2021 | (7/01/20 - 6/30/21) | 1% of Total Amount Bid |

The Contractor shall also furnish his own progress schedule in accordance with Article 108-2 of the *2012 Standard Specifications*. Any acceleration of the progress as shown by the Contractor's progress schedule over the progress as shown above shall be subject to the approval of the Engineer.

MINORITY BUSINESS ENTERPRISE AND WOMEN BUSINESS ENTERPRISE:

(10-16-07)(Rev. 1-17-17)

102-15(J)

SP1 G66

Description

The purpose of this Special Provision is to carry out the North Carolina Department of Transportation's policy of ensuring nondiscrimination in the award and administration of contracts financed in whole or in part with State funds.

Definitions

Additional MBE/WBE Subcontractors - Any MBE/WBE submitted at the time of bid that will not be used to meet either the MBE or WBE goal. No submittal of a Letter of Intent is required, unless the additional participation is used for banking purposes.

Committed MBE/WBE Subcontractor - Any MBE/WBE submitted at the time of bid that is being used to meet either the MBE or WBE goal by submission of a Letter of Intent. Or any MBE or WBE used as a replacement for a previously committed MBE or WBE firm.

Contract Goals Requirement - The approved MBE and WBE participation at time of award, but not greater than the advertised contract goals for each.

Goal Confirmation Letter - Written documentation from the Department to the bidder confirming the Contractor's approved, committed MBE and WBE participation along with a listing of the committed MBE and WBE firms.

Manufacturer - A firm that operates or maintains a factory or establishment that produces on the premises, the materials or supplies obtained by the Contractor.

MBE Goal - A portion of the total contract, expressed as a percentage, that is to be performed by committed MBE subcontractor(s).

Minority Business Enterprise (MBE) - A firm certified as a Disadvantaged Minority-Owned Business Enterprise through the North Carolina Unified Certification Program.

Regular Dealer - A firm that owns, operates, or maintains a store, warehouse, or other establishment in which the materials or supplies required for the performance of the contract are bought, kept in stock, and regularly sold to the public in the usual course of business. A regular dealer engages in, as its principal business and in its own name, the purchase and sale or lease of the products in question. A regular dealer in such bulk items as steel, cement, gravel, stone, and petroleum products need not keep such products in stock, if it owns and operates distribution equipment for the products. Brokers and packagers are not regarded as manufacturers or regular dealers within the meaning of this section.

North Carolina Unified Certification Program (NCUCP) - A program that provides comprehensive services and information to applicants for MBE/WBE certification. The MBE/WBE program follows the same regulations as the federal Disadvantaged Business Enterprise (DBE) program in accordance with 49 CFR Part 26.

United States Department of Transportation (USDOT) - Federal agency responsible for issuing regulations (49 CFR Part 26) and official guidance for the DBE program.

WBE Goal - A portion of the total contract, expressed as a percentage, that is to be performed by committed WBE subcontractor(s).

Women Business Enterprise (WBE) - A firm certified as a Disadvantaged Women-Owned Business Enterprise through the North Carolina Unified Certification Program.

Forms and Websites Referenced in this Provision

Payment Tracking System - On-line system in which the Contractor enters the payments made to MBE and WBE subcontractors who have performed work on the project.
<https://apps.dot.state.nc.us/Vendor/PaymentTracking/>

DBE-IS Subcontractor Payment Information - Form for reporting the payments made to all MBE/WBE firms working on the project. This form is for paper bid projects only.
<https://connect.ncdot.gov/business/Turnpike/Documents/Form%20DBE-IS%20Subcontractor%20Payment%20Information.pdf>

RF-1 MBE/WBE Replacement Request Form - Form for replacing a committed MBE or WBE.
<http://connect.ncdot.gov/projects/construction/Construction%20Forms/DBE%20MBE%20WBE%20Replacement%20Request%20Form.pdf>

SAF Subcontract Approval Form - Form required for approval to sublet the contract.
<http://connect.ncdot.gov/projects/construction/Construction%20Forms/Subcontract%20Approval%20Form%20Rev.%202012.zip>

JC-1 Joint Check Notification Form - Form and procedures for joint check notification. The form acts as a written joint check agreement among the parties providing full and prompt disclosure of the expected use of joint checks.
<http://connect.ncdot.gov/projects/construction/Construction%20Forms/Joint%20Check%20Notification%20Form.pdf>

Letter of Intent - Form signed by the Contractor and the MBE/WBE subcontractor, manufacturer or regular dealer that affirms that a portion of said contract is going to be performed by the signed MBE/WBE for the amount listed at the time of bid.
<http://connect.ncdot.gov/letting/LetCentral/Letter%20of%20Intent%20to%20Perform%20as%20a%20Subcontractor.pdf>

Listing of MBE and WBE Subcontractors Form - Form for entering MBE/WBE subcontractors on a project that will meet this MBE and WBE goals. This form is for paper bids only.
[http://connect.ncdot.gov/municipalities/Bid%20Proposals%20for%20LGA%20Content/09%20MBE-WBE%20Subcontractors%20\(State\).docx](http://connect.ncdot.gov/municipalities/Bid%20Proposals%20for%20LGA%20Content/09%20MBE-WBE%20Subcontractors%20(State).docx)

Subcontractor Quote Comparison Sheet - Spreadsheet for showing all subcontractor quotes in the work areas where MBEs and WBEs quoted on the project. This sheet is submitted with good faith effort packages.
<http://connect.ncdot.gov/business/SmallBusiness/Documents/DBE%20Subcontractor%20Quote%20Comparison%20Example.xls>

MBE and WBE Goal

The following goals for participation by Minority Business Enterprises and Women Business Enterprises are established for this contract:

(A) Minority Business Enterprises 4.0 %

- (1) *If the MBE goal is more than zero*, the Contractor shall exercise all necessary and reasonable steps to ensure that MBEs participate in at least the percent of the contract as set forth above as the MBE goal.
- (2) *If the MBE goal is zero*, the Contractor shall make an effort to recruit and use MBEs during the performance of the contract. Any MBE participation obtained shall be reported to the Department.

(B) Women Business Enterprises 5.0 %

- (1) *If the WBE goal is more than zero*, the Contractor shall exercise all necessary and reasonable steps to ensure that WBEs participate in at least the percent of the contract as set forth above as the WBE goal.
- (2) *If the WBE goal is zero*, the Contractor shall make an effort to recruit and use WBEs during the performance of the contract. Any WBE participation obtained shall be reported to the Department.

Directory of Transportation Firms (Directory)

Real-time information is available about firms doing business with the Department and firms that are certified through NCUCP in the Directory of Transportation Firms. Only firms identified in the Directory as MBE and WBE certified shall be used to meet the MBE and WBE goals respectively. The Directory can be found at the following link. <https://www.ebs.nc.gov/VendorDirectory/default.html>

The listing of an individual firm in the directory shall not be construed as an endorsement of the firm's capability to perform certain work.

Listing of MBE/WBE Subcontractors

At the time of bid, bidders shall submit all MBE and WBE participation that they anticipate to use during the life of the contract. Only those identified to meet the MBE goal and the WBE goal will be considered committed, even though the listing shall include both committed MBE/WBE subcontractors and additional MBE/WBE subcontractors. Any additional MBE/WBE subcontractor participation above the goal for which letters of intent are received will follow the banking guidelines found elsewhere in this provision. All other additional MBE/WBE subcontractor participation submitted at the time of bid will be used toward the Department's overall race-neutral goals. Only those firms with current MBE and WBE certification at the time of bid opening will be acceptable for listing in the bidder's submittal of MBE and WBE participation. The Contractor shall indicate the following required information:

(A) Electronic Bids

Bidders shall submit a listing of MBE and WBE participation in the appropriate section of Expedite, the bidding software of Bid Express®.

- (1) Submit the names and addresses of MBE and WBE firms identified to participate in the contract. If the bidder uses the updated listing of MBE and WBE firms shown in Expedite, the bidder may use the dropdown menu to access the name and address of the firms.
- (2) Submit the contract line numbers of work to be performed by each MBE and WBE firm. When no figures or firms are entered, the bidder will be considered to have no MBE or WBE participation.
- (3) The bidder shall be responsible for ensuring that the MBE and WBE are certified at the time of bid by checking the Directory of Transportation Firms. If the firm is not certified at the time of the bid-letting, that MBE's or WBE's participation will not count towards achieving either the MBE or WBE goal.

(B) Paper Bids

- (1) *If either the MBE or WBE goal is more than zero,*
 - (a) Bidders, at the time the bid proposal is submitted, shall submit a listing of MBE/WBE participation, including the names and addresses on *Listing of MBE and WBE Subcontractors* contained elsewhere in the contract documents in order for the bid to be considered responsive. Bidders shall indicate the total dollar value of the MBE and WBE participation for the contract.
 - (b) If bidders have no MBE or WBE participation, they shall indicate this on the *Listing of MBE and WBE Subcontractors* by entering the word "None" or the number "0." This form shall be completed in its entirety. **Blank forms will not be deemed to represent zero participation.** Bids submitted that do not have MBE and WBE participation indicated on the appropriate form will not be read publicly during the opening of bids. The Department will not consider these bids for award and the proposal will be rejected.
 - (c) The bidder shall be responsible for ensuring that the MBE/WBE is certified at the time of bid by checking the Directory of Transportation Firms. If the firm is not certified at the time of the bid-letting, that MBE's or WBE's participation will not count towards achieving the corresponding goal.
- (2) *If either the MBE or WBE goal is zero,* entries on the *Listing of MBE and WBE Subcontractors* are not required for the zero goal, however any MBE or WBE

participation that is achieved during the project shall be reported in accordance with requirements contained elsewhere in the special provision.

MBE or WBE Prime Contractor

When a certified MBE or WBE firm bids on a contract that contains MBE and WBE goals, the firm is responsible for meeting the goals or making good faith efforts to meet the goals, just like any other bidder. In most cases, a MBE or WBE bidder on a contract will meet one of the goals by virtue of the work it performs on the contract with its own forces. However, all the work that is performed by the MBE or WBE bidder and any other similarly certified subcontractors will count toward the goal. The MBE or WBE bidder shall list itself along with any MBE or WBE subcontractors, if any, in order to receive credit toward the goals.

For example, on a proposed contract, the WBE goal is 10%, and the MBE goal is 8%. A WBE bidder puts in a bid where they will perform 40% of the contract work and have a WBE subcontractor which will perform another 5% of the work. Together the two WBE firms submit on the *Listing of MBE and WBE Subcontractors* a value of 45% of the contract which fulfills the WBE goal. The 8% MBE goal shall be obtained through MBE participation with MBE certified subcontractors or documented through a good faith effort. It should be noted that you cannot combine the two goals to meet an overall value. The two goals shall remain separate.

MBE/WBE prime contractors shall also follow Sections A and B listed under *Listing of MBE and WBE Subcontractor* just as a non-MBE/WBE bidder would.

Written Documentation – Letter of Intent

The bidder shall submit written documentation for each MBE/WBE that will be used to meet the MBE and WBE goals of the contract, indicating the bidder's commitment to use the MBE/WBE in the contract. This documentation shall be submitted on the Department's form titled *Letter of Intent*.

The documentation shall be received in the office of the State Contractor Utilization Engineer or at DBE@ncdot.gov no later than 10:00 a.m. of the sixth calendar day following opening of bids, unless the sixth day falls on an official state holiday. In that situation, it is due in the office of the State Contractor Utilization Engineer no later than 10:00 a.m. on the next official state business day.

If the bidder fails to submit the Letter of Intent from each committed MBE and WBE to be used toward the MBE and WBE goals, or if the form is incomplete (i.e. both signatures are not present), the MBE/WBE participation will not count toward meeting the MBE/WBE goal. If the lack of this participation drops the commitment below either the MBE or WBE goal, the Contractor shall submit evidence of good faith efforts for the goal not met, completed in its entirety, to the State Contractor Utilization Engineer or DBE@ncdot.gov no later than 10:00 a.m. on the eighth calendar day following opening of bids, unless the eighth day falls on an official state holiday. In that situation, it is due in the office of the State Contractor Utilization Engineer no later than 10:00 a.m. on the next official state business day.

Banking MBE/WBE Credit

If the bid of the lowest responsive bidder exceeds \$500,000 and if the committed MBE/WBE participation submitted by Letter of Intent exceeds the algebraic sum of the MBE or WBE goal by \$1,000 or more, the excess will be placed on deposit by the Department for future use by the bidder. Separate accounts will be maintained for MBE and WBE participation and these may accumulate for a period not to exceed 24 months.

When the apparent lowest responsive bidder fails to submit sufficient participation by MBE firms to meet the contract goal, as part of the good faith effort, the Department will consider allowing the bidder to withdraw funds to meet the MBE goal as long as there are adequate funds available from the bidder's MBE bank account.

When the apparent lowest responsive bidder fails to submit sufficient participation by WBE firms to meet the contract goal, as part of the good faith effort, the Department will consider allowing the bidder to withdraw funds to meet the WBE goal as long as there are adequate funds available from the bidder's WBE bank account.

Submission of Good Faith Effort

If the bidder fails to meet or exceed either the MBE or the WBE goal, the apparent lowest responsive bidder shall submit to the Department documentation of adequate good faith efforts made to reach that specific goal(s).

A hard copy and an electronic copy of this information shall be received in the office of the State Contractor Utilization Engineer or at DBE@ncdot.gov no later than 10:00 a.m. on the sixth calendar day following opening of bids unless the sixth day falls on an official state holiday. In that situation, it would be due in the office of the State Contractor Utilization Engineer no later than 10:00 a.m. on the next official state business day. If the contractor cannot send the information electronically, then one complete set and 9 copies of this information shall be received under the same time constraints above.

Note: Where the information submitted includes repetitious solicitation letters, it will be acceptable to submit a representative letter along with a distribution list of the firms that were solicited. Documentation of MBE/WBE quotations shall be a part of the good faith effort submittal. This documentation may include written subcontractor quotations, telephone log notations of verbal quotations, or other types of quotation documentation.

Consideration of Good Faith Effort for Projects with MBE/WBE Goals More Than Zero

Adequate good faith efforts mean that the bidder took all necessary and reasonable steps to achieve the goal which, by their scope, intensity, and appropriateness, could reasonably be expected to obtain sufficient MBE/WBE participation. Adequate good faith efforts also mean that the bidder actively and aggressively sought MBE/WBE participation. Mere *pro forma* efforts are not considered good faith efforts.

The Department will consider the quality, quantity, and intensity of the different kinds of efforts a bidder has made. Listed below are examples of the types of actions a bidder will take in making a good faith effort to meet the goals and are not intended to be exclusive or exhaustive, nor is it intended to be a mandatory checklist.

- (A) Soliciting through all reasonable and available means (e.g. attendance at pre-bid meetings, advertising, written notices, use of verifiable electronic means through the use of the NCDOT Directory of Transportation Firms) the interest of all certified MBEs/WBEs that are also prequalified subcontractors. The bidder must solicit this interest within at least 10 days prior to bid opening to allow the MBEs/WBEs to respond to the solicitation. Solicitation shall provide the opportunity to MBEs/WBEs within the Division and surrounding Divisions where the project is located. The bidder must determine with certainty if the MBEs/WBEs are interested by taking appropriate steps to follow up initial solicitations.
- (B) Selecting portions of the work to be performed by MBEs/WBEs in order to increase the likelihood that the MBE and WBE goals will be achieved.
 - (1) Where appropriate, break out contract work items into economically feasible units to facilitate MBE/WBE participation, even when the prime contractor might otherwise prefer to perform these work items with its own forces.
 - (2) Negotiate with subcontractors to assume part of the responsibility to meet the contract MBE/WBE goals when the work to be sublet includes potential for MBE/WBE participation (2nd and 3rd tier subcontractors).
- (C) Providing interested certified MBEs/WBEs that are also prequalified subcontractors with adequate information about the plans, specifications, and requirements of the contract in a timely manner to assist them in responding to a solicitation.
- (D)
 - (1) Negotiating in good faith with interested MBEs/WBEs. It is the bidder's responsibility to make a portion of the work available to MBE/WBE subcontractors and suppliers and to select those portions of the work or material needs consistent with the available MBE/WBE subcontractors and suppliers, so as to facilitate MBE/WBE participation. Evidence of such negotiation includes the names, addresses, and telephone numbers of MBEs/WBEs that were considered; a description of the information provided regarding the plans and specifications for the work selected for subcontracting; and evidence as to why additional agreements could not be reached for MBEs/WBEs to perform the work.
 - (2) A bidder using good business judgment would consider a number of factors in negotiating with subcontractors, including MBE/WBE subcontractors, and would take a firm's price and capabilities as well as contract goals into consideration. However, the fact that there may be some additional costs involved in finding and using MBEs/WBEs is not in itself sufficient reason for a bidder's failure to meet the contract MBE or WBE goals, as long as such costs are reasonable. Also, the ability or desire of a prime contractor to perform the work of a contract with its own organization does not relieve the bidder of the responsibility

to make good faith efforts. Bidding contractors are not, however, required to accept higher quotes from MBEs/WBEs if the price difference is excessive or unreasonable.

- (E) Not rejecting MBEs/WBEs as being unqualified without sound reasons based on a thorough investigation of their capabilities. The bidder's standing within its industry, membership in specific groups, organizations, or associates and political or social affiliations (for example, union vs. non-union employee status) are not legitimate causes for the rejection or non-solicitation of bids in the bidder's efforts to meet the project goal.
- (F) Making efforts to assist interested MBEs/WBEs in obtaining bonding, lines of credit, or insurance as required by the recipient or bidder.
- (G) Making efforts to assist interested MBEs/WBEs in obtaining necessary equipment, supplies, materials, or related assistance or services.
- (H) Effectively using the services of available minority/women community organizations; minority/women contractors' groups; Federal, State, and local minority/women business assistance offices; and other organizations as allowed on a case-by-case basis to provide assistance in the recruitment and placement of MBEs/WBEs. Contact within 7 days from the bid opening the Business Opportunity and Work Force Development Unit at DBE@ncdot.gov to give notification of the bidder's inability to get MBE or WBE quotes.
- (I) Any other evidence that the bidder submits which shows that the bidder has made reasonable good faith efforts to meet the MBE and WBE goal.

In addition, the Department may take into account the following:

- (1) Whether the bidder's documentation reflects a clear and realistic plan for achieving the MBE and WBE goals.
- (2) The bidders' past performance in meeting the MBE and WBE goals.
- (3) The performance of other bidders in meeting the MBE and WBE goals. For example, when the apparent successful bidder fails to meet the goals, but others meet it, you may reasonably raise the question of whether, with additional reasonable efforts the apparent successful bidder could have met the goals. If the apparent successful bidder fails to meet the MBE and WBE goals, but meets or exceeds the average MBE and WBE participation obtained by other bidders, the Department may view this, in conjunction with other factors, as evidence of the apparent successful bidder having made a good faith effort.

If the Department does not award the contract to the apparent lowest responsive bidder, the Department reserves the right to award the contract to the next lowest responsive bidder that can satisfy to the Department that the MBE and WBE goals can be met or that an adequate good faith effort has been made to meet the MBE and WBE goals.

Non-Good Faith Appeal

The State Contractual Services Engineer will notify the contractor verbally and in writing of non-good faith. A contractor may appeal a determination of non-good faith made by the Goal Compliance Committee. If a contractor wishes to appeal the determination made by the Committee, they shall provide written notification to the State Contractual Services Engineer or at DBE@ncdot.gov. The appeal shall be made within 2 business days of notification of the determination of non-good faith.

Counting MBE/WBE Participation Toward Meeting MBE/WBE Goals**(A) Participation**

The total dollar value of the participation by a committed MBE/WBE will be counted toward the contract goal requirements. The total dollar value of participation by a committed MBE/WBE will be based upon the value of work actually performed by the MBE/WBE and the actual payments to MBE/WBE firms by the Contractor.

(B) Joint Checks

Prior notification of joint check use shall be required when counting MBE/WBE participation for services or purchases that involves the use of a joint check. Notification shall be through submission of Form JC-1 (*Joint Check Notification Form*) and the use of joint checks shall be in accordance with the Department's Joint Check Procedures.

(C) Subcontracts (Non-Trucking)

A MBE/WBE may enter into subcontracts. Work that a MBE subcontracts to another MBE firm may be counted toward the MBE contract goal requirement. The same holds for work that a WBE subcontracts to another WBE firm. Work that a MBE subcontracts to a non-MBE firm does not count toward the MBE contract goal requirement. Again, the same holds true for the work that a WBE subcontracts to a non-WBE firm. If a MBE or WBE contractor or subcontractor subcontracts a significantly greater portion of the work of the contract than would be expected on the basis of standard industry practices, it shall be presumed that the MBE or WBE is not performing a commercially useful function. The MBE/WBE may present evidence to rebut this presumption to the Department. The Department's decision on the rebuttal of this presumption may be subject to review by the Office of Inspector General, NCDOT.

(D) Joint Venture

When a MBE or WBE performs as a participant in a joint venture, the Contractor may count toward its contract goal requirement a portion of the total value of participation with the MBE or WBE in the joint venture, that portion of the total dollar value being a distinct clearly defined portion of work that the MBE or WBE performs with its forces.

(E) Suppliers

A contractor may count toward its MBE or WBE requirement 60 percent of its expenditures for materials and supplies required to complete the contract and obtained from a MBE or WBE regular dealer and 100 percent of such expenditures from a MBE or WBE manufacturer.

(F) Manufacturers and Regular Dealers

A contractor may count toward its MBE or WBE requirement the following expenditures to MBE/WBE firms that are not manufacturers or regular dealers:

- (1) The fees or commissions charged by a MBE/WBE firm for providing a *bona fide* service, such as professional, technical, consultant, or managerial services, or for providing bonds or insurance specifically required for the performance of a DOT-assisted contract, provided the fees or commissions are determined to be reasonable and not excessive as compared with fees and commissions customarily allowed for similar services.
- (2) With respect to materials or supplies purchased from a MBE/WBE, which is neither a manufacturer nor a regular dealer, count the entire amount of fees or commissions charged for assistance in the procurement of the materials and supplies, or fees or transportation charges for the delivery of materials or supplies required on a job site (but not the cost of the materials and supplies themselves), provided the fees are determined to be reasonable and not excessive as compared with fees customarily allowed for similar services.

Commercially Useful Function

(A) MBE/WBE Utilization

The Contractor may count toward its contract goal requirement only expenditures to MBEs and WBEs that perform a commercially useful function in the work of a contract. A MBE/WBE performs a commercially useful function when it is responsible for execution of the work of the contract and is carrying out its responsibilities by actually performing, managing, and supervising the work involved. To perform a commercially useful function, the MBE/WBE shall also be responsible with respect to materials and supplies used on the contract, for negotiating price, determining quality and quantity, ordering the material and installing (where applicable) and paying for the material itself. To determine whether a MBE/WBE is performing a commercially useful function, the Department will evaluate the amount of work subcontracted, industry practices, whether the amount the firm is to be paid under the contract is commensurate with the work it is actually performing and the MBE/WBE credit claimed for its performance of the work, and any other relevant factors.

(B) MBE/WBE Utilization in Trucking

The following factors will be used to determine if a MBE or WBE trucking firm is performing a commercially useful function:

- (1) The MBE/WBE shall be responsible for the management and supervision of the entire trucking operation for which it is responsible on a particular contract, and there shall not be a contrived arrangement for the purpose of meeting the MBE or WBE goal.
- (2) The MBE/WBE shall itself own and operate at least one fully licensed, insured, and operational truck used on the contract.
- (3) The MBE/WBE receives credit for the total value of the transportation services it provides on the contract using trucks it owns, insures, and operates using drivers it employs.
- (4) The MBE may subcontract the work to another MBE firm, including an owner-operator who is certified as a MBE. The same holds true that a WBE may subcontract the work to another WBE firm, including an owner-operator who is certified as a WBE. When this occurs, the MBE or WBE who subcontracts work receives credit for the total value of the transportation services the subcontracted MBE or WBE provides on the contract. It should be noted that every effort shall be made by MBE and WBE contractors to subcontract to the same certification (i.e., MBEs to MBEs and WBEs to WBEs), in order to fulfill the goal requirement. This, however, may not always be possible due to the limitation of firms in the area. If the MBE or WBE firm shows a good faith effort has been made to reach out to similarly certified transportation service providers and there is no interest or availability, and they can get assistance from other certified providers, the Engineer will not hold the prime liable for meeting the goal.
- (5) The MBE/WBE may also subcontract the work to a non-MBE/WBE firm, including from an owner-operator. The MBE/WBE who subcontracts the work to a non-MBE/WBE is entitled to credit for the total value of transportation services provided by the non-MBE/WBE subcontractor not to exceed the value of transportation services provided by MBE/WBE-owned trucks on the contract. Additional participation by non-MBE/WBE subcontractors receives credit only for the fee or commission it receives as a result of the subcontract arrangement. The value of services performed under subcontract agreements between the MBE/WBE and the Contractor will not count towards the MBE/WBE contract requirement.
- (6) A MBE/WBE may lease truck(s) from an established equipment leasing business open to the general public. The lease must indicate that the MBE/WBE has exclusive use of and control over the truck. This requirement does not preclude the leased truck from working for others during the term of the lease with the consent of the MBE/WBE, so long as the lease gives the MBE/WBE absolute priority for use of the leased truck. This type of lease may count toward the MBE/WBE's credit as long as the driver is under the MBE/WBE's payroll.

- (7) Subcontracted/leased trucks shall display clearly on the dashboard the name of the MBE/WBE that they are subcontracted/leased to and their own company name if it is not identified on the truck itself. Magnetic door signs are not permitted.

MBE/WBE Replacement

When a Contractor has relied on a commitment to a MBE or WBE firm (or an approved substitute MBE or WBE firm) to meet all or part of a contract goal requirement, the contractor shall not terminate the MBE/WBE for convenience. This includes, but is not limited to, instances in which the Contractor seeks to perform the work of the terminated subcontractor with another MBE/WBE subcontractor, a non-MBE/WBE subcontractor, or with the Contractor's own forces or those of an affiliate. A MBE/WBE may only be terminated after receiving the Engineer's written approval based upon a finding of good cause for the termination. The prime contractor must give the MBE/WBE firm five (5) calendar days to respond to the prime contractor's notice of termination and advise the prime contractor and the Department of the reasons, if any, why the firm objects to the proposed termination of its subcontract and why the Department should not approve the action. All requests for replacement of a committed MBE/WBE firm shall be submitted to the Engineer for approval on Form RF-1 (*Replacement Request*). If the Contractor fails to follow this procedure, the Contractor may be disqualified from further bidding for a period of up to 6 months.

The Contractor shall comply with the following for replacement of a committed MBE/WBE:

(A) Performance Related Replacement

When a committed MBE is terminated for good cause as stated above, an additional MBE that was submitted at the time of bid may be used to fulfill the MBE commitment. The same holds true if a committed WBE is terminated for good cause, an additional WBE that was submitted at the time of bid may be used to fulfill the WBE goal. A good faith effort will only be required for removing a committed MBE/WBE if there were no additional MBEs/WBEs submitted at the time of bid to cover the same amount of work as the MBE/WBE that was terminated.

If a replacement MBE/WBE is not found that can perform at least the same amount of work as the terminated MBE/WBE, the Contractor shall submit a good faith effort documenting the steps taken. Such documentation shall include, but not be limited to, the following:

- (1) Copies of written notification to MBEs/WBEs that their interest is solicited in contracting the work defaulted by the previous MBE/WBE or in subcontracting other items of work in the contract.
- (2) Efforts to negotiate with MBEs/WBEs for specific subbids including, at a minimum:
 - (a) The names, addresses, and telephone numbers of MBEs/WBEs who were contacted.
 - (b) A description of the information provided to MBEs/WBEs regarding the plans and specifications for portions of the work to be performed.

- (3) A list of reasons why MBE/WBE quotes were not accepted.
 - (4) Efforts made to assist the MBEs/WBEs contacted, if needed, in obtaining bonding or insurance required by the Contractor.
- (B) Decertification Replacement
- (1) When a committed MBE/WBE is decertified by the Department after the SAF (*Subcontract Approval Form*) has been received by the Department, the Department will not require the Contractor to solicit replacement MBE/WBE participation equal to the remaining work to be performed by the decertified firm. The participation equal to the remaining work performed by the decertified firm will count toward the contract goal requirement.
 - (2) When a committed MBE/WBE is decertified prior to the Department receiving the SAF (*Subcontract Approval Form*) for the named MBE/WBE firm, the Contractor shall take all necessary and reasonable steps to replace the MBE/WBE subcontractor with another similarly certified MBE/WBE subcontractor to perform at least the same amount of work to meet the MBE/WBE goal requirement. If a MBE/WBE firm is not found to do the same amount of work, a good faith effort must be submitted to NCDOT (see A herein for required documentation).

Changes in the Work

When the Engineer makes changes that result in the reduction or elimination of work to be performed by a committed MBE/WBE, the Contractor will not be required to seek additional participation. When the Engineer makes changes that result in additional work to be performed by a MBE/WBE based upon the Contractor's commitment, the MBE/WBE shall participate in additional work to the same extent as the MBE/WBE participated in the original contract work.

When the Engineer makes changes that result in extra work, which has more than a minimal impact on the contract amount, the Contractor shall seek additional participation by MBEs/WBEs unless otherwise approved by the Engineer.

When the Engineer makes changes that result in an alteration of plans or details of construction, and a portion or all of the work had been expected to be performed by a committed MBE/WBE, the Contractor shall seek participation by MBEs/WBEs unless otherwise approved by the Engineer.

When the Contractor requests changes in the work that result in the reduction or elimination of work that the Contractor committed to be performed by a MBE/WBE, the Contractor shall seek additional participation by MBEs/WBEs equal to the reduced MBE/WBE participation caused by the changes.

Reports and Documentation

A SAF (*Subcontract Approval Form*) shall be submitted for all work which is to be performed by a MBE/WBE subcontractor. The Department reserves the right to require copies of actual subcontract agreements involving MBE/WBE subcontractors.

When using transportation services to meet the contract commitment, the Contractor shall submit a proposed trucking plan in addition to the SAF. The plan shall be submitted prior to beginning construction on the project. The plan shall include the names of all trucking firms proposed for use, their certification type(s), the number of trucks owned by the firm, as well as the individual truck identification numbers, and the line item(s) being performed.

Within 30 calendar days of entering into an agreement with a MBE/WBE for materials, supplies or services, not otherwise documented by the SAF as specified above, the Contractor shall furnish the Engineer a copy of the agreement. The documentation shall also indicate the percentage (60% or 100%) of expenditures claimed for MBE/WBE credit.

Reporting Minority and Women Business Enterprise Participation

The Contractor shall provide the Engineer with an accounting of payments made to all MBE and WBE firms, including material suppliers and contractors at all levels (prime, subcontractor, or second tier subcontractor). This accounting shall be furnished to the Engineer for any given month by the end of the following month. Failure to submit this information accordingly may result in the following action:

- (A) Withholding of money due in the next partial pay estimate; or
- (B) Removal of an approved contractor from the prequalified bidders' list or the removal of other entities from the approved subcontractors list.

While each contractor (prime, subcontractor, 2nd tier subcontractor) is responsible for accurate accounting of payments to MBEs/WBEs, it shall be the prime contractor's responsibility to report all monthly and final payment information in the correct reporting manner.

Failure on the part of the Contractor to submit the required information in the time frame specified may result in the disqualification of that contractor and any affiliate companies from further bidding until the required information is submitted.

Failure on the part of any subcontractor to submit the required information in the time frame specified may result in the disqualification of that contractor and any affiliate companies from being approved for work on future DOT projects until the required information is submitted.

Contractors reporting transportation services provided by non-MBE/WBE lessees shall evaluate the value of services provided during the month of the reporting period only.

At any time, the Engineer can request written verification of subcontractor payments.

The Contractor shall report the accounting of payments through the Department's Payment Tracking System.

Failure to Meet Contract Requirements

Failure to meet contract requirements in accordance with Subarticle 102-15(J) of the *2012 Standard Specifications* may be cause to disqualify the Contractor.

CONTRACTOR'S LICENSE REQUIREMENTS:

(7-1-95)

102-14

SP1 G88

If the successful bidder does not hold the proper license to perform any plumbing, heating, air conditioning, or electrical work in this contract, he will be required to sublet such work to a contractor properly licensed in accordance with *Article 2 of Chapter 87 of the General Statutes* (licensing of heating, plumbing, and air conditioning contractors) and *Article 4 of Chapter 87 of the General Statutes* (licensing of electrical contractors).

SUBSURFACE INFORMATION:

(7-1-95)

450

SP1 G112 D

Subsurface information is available on the roadway and structure portions of this project.

LOCATING EXISTING UNDERGROUND UTILITIES:

(3-20-12)

105

SP1 G115

Revise the *2012 Standard Specifications* as follows:

Page 1-43, Article 105-8, line 28, after the first sentence, add the following:

Identify excavation locations by means of pre-marking with white paint, flags, or stakes or provide a specific written description of the location in the locate request.

VALUE ENGINEERING PROPOSAL:

(05-19-15)

104

SP01 G116

Revise the *2012 Standard Specifications* as follows:

Page 1-36, Subarticle 104-12(B) Evaluation of Proposals, lines 42-44, replace the fourth sentence of the second paragraph with the following:

Pending execution of a formal supplemental agreement implementing an approved VEP and transfer of final plans (hard copy and electronic) sealed by an engineer licensed in the State of North Carolina incorporating an approved VEP to the Resident Engineer and the State Value Management Engineer, the Contractor shall remain obligated to perform the work in accordance with the terms of the existing contract.

Page 1-37, Subarticle 104-12(D) Preliminary Review, lines 9-12, replace the first sentence of the first paragraph with the following:

Should the Contractor desire a preliminary review of a possible VEP, before expending considerable time and expense in full development, a copy of the Preliminary VEP shall be

submitted to the Resident Engineer and the State Value Management Engineer at ValueManagementUnit@ncdot.gov.

Page 1-37, Subarticle 104-12(E) Final Proposal, lines 22-23, replace the first sentence of the first paragraph with the following:

A copy of the Final VEP shall be submitted by the Contractor to the Resident Engineer and the State Value Management Engineer at ValueManagementUnit@ncdot.gov.

Page 1-38, Subarticle 104-12(F) Modifications, lines 2-8, replace the first paragraph with the following:

To facilitate the preparation of revisions to contract drawings, the Contractor may purchase reproducible copies of drawings for his use through the Department's Value Management Unit. The preparation of new design drawings by or for the Contractor shall be coordinated with the appropriate Design Branch through the State Value Management Engineer. The Contractor shall provide, at no charge to the Department, one set of reproducible drawings of the approved design needed to implement the VEP. Drawings (hard copy and electronic) which are sealed by an engineer licensed in the State of North Carolina shall be submitted to the State Value Management Engineer no later than ten (10) business days after acceptance of a VEP unless otherwise permitted.

Page 1-38, Subarticle 104-12(F) Modifications, line 17, add the following at the end of the third paragraph:

Supplemental agreements executed for design-bid-build contracts shall reflect any realized savings in the corresponding line items. Supplemental agreements executed for design-build contracts shall add one line item deducting the full savings from the total contract price and one line item crediting the Contractor with 50% of the total VEP savings.

Page 1-38, Subarticle 104-12(F) Modifications, lines 45-47, replace the eighth paragraph with the following:

Unless and until a supplemental agreement is executed and issued by the Department and final plans (hard copy and electronic) sealed by an engineer licensed in the State of North Carolina incorporating an approved VEP have been provided to the Resident Engineer and the State Value Management Engineer, the Contractor shall remain obligated to perform the work in accordance with the terms of the existing contract.

RESOURCE CONSERVATION AND ENV. SUSTAINABLE PRACTICES:

(5-21-13) (Rev. 5-19-15)

104-13

SP1 G118

In accordance with North Carolina Executive Order 156, NCGS 130A-309.14(3), and NCGS 136-28.8, it is the objective of the Department to aid in the reduction of materials that become a part of our solid waste stream, to divert materials from landfills, to find ways to recycle and reuse materials, to consider and minimize, where economically feasible, the environmental impacts associated with agency land use and acquisition, construction, maintenance and facility management for the benefit of the Citizens of North Carolina.

To achieve the mission of reducing environmental impacts across the state, the Department is committed to supporting the efforts to initiate, develop and use products and construction methods that incorporate the use of recycled, solid waste products and environmentally sustainable practices in accordance with Article 104-13 of the *Standard Specifications*.

Report the quantities of reused or recycled materials either incorporated in the project or diverted from landfills and any practice that minimizes the environmental impact on the project annually on the Project Construction Reuse and Recycling Reporting Form. The Project Construction Reuse and Recycling Reporting Form and a location tool for local recycling facilities are available at:

<http://connect.ncdot.gov/resources/Environmental/Pages/North-Carolina-Recycling-Locations.aspx>.

Submit the Project Construction Reuse and Recycling Reporting Form by August 1 annually to valuemanagementunit@ncdot.gov. For questions regarding the form or reporting, please contact the State Value Management Engineer at 919-707-4810.

DOMESTIC STEEL:

(4-16-13)

106

SP1 G120

Revise the *2012 Standard Specifications* as follows:

Page 1-49, Subarticle 106-1(B) Domestic Steel, lines 2-7, replace the first paragraph with the following:

All steel and iron products that are permanently incorporated into this project shall be produced in the United States except minimal amounts of foreign steel and iron products may be used provided the combined material cost of the items involved does not exceed 0.1% of the total amount bid for the entire project or \$2,500, whichever is greater. If invoices showing the cost of the material are not provided, the amount of the bid item involving the foreign material will be used for calculations. This minimal amount of foreign produced steel and iron products permitted for use is not applicable to high strength fasteners. Domestically produced high strength fasteners are required.

PORTABLE CONCRETE BARRIER - (Partial Payments for Materials):

(7-1-95) (Rev. 8-16-11)

1170-4

SP1 G121

When so authorized by the Engineer, partial materials payments will be made up to 95 percent of the delivered cost of portable concrete barrier, provided that these materials have been delivered on the project and stored in an acceptable manner, and further provided the documents listed in Subarticle 109-5(C) of the *2012 Standard Specifications* have been furnished to the Engineer.

The provisions of Subarticle 109-5(B) of the *2012 Standard Specifications* will apply to the portable concrete barrier.

REMOVABLE PAVEMENT MARKINGS - (Partial Payments for Materials):

(7-1-95) (Rev. 8-16-11)

1205-10

SP1 G124

When so authorized by the Engineer, partial materials payments will be made up to 95 percent of the delivered cost of pavement marking tape, provided that these materials have been delivered on or in the vicinity of the project, stored in an acceptable manner, not to exceed the shelf life recommended by the manufacturer, and further provided the documents listed in Subarticle 109-5(C) of the *2012 Standard Specifications* have been furnished to the Engineer.

The Contractor shall be responsible for the material and the satisfactory performance of the material when used in the work.

The provisions of Article 109-6 of the *2012 Standard Specifications* will not apply to removable pavement marking materials.

MAINTENANCE OF THE PROJECT:

(11-20-07) (Rev. 1-17-12)

104-10

SP1 G125

Revise the *2012 Standard Specifications* as follows:

Page 1-35, Article 104-10 Maintenance of the Project, line 25, add the following after the first sentence of the first paragraph:

All guardrail/guiderail within the project limits shall be included in this maintenance.

Page 1-35, Article 104-10 Maintenance of the Project, line 30, add the following as the last sentence of the first paragraph:

The Contractor shall perform weekly inspections of guardrail and guiderail and shall report damages to the Engineer on the same day of the weekly inspection. *Where damaged guardrail or guiderail is repaired or replaced as a result of maintaining the project* in accordance with this article, such repair or replacement shall be performed within 7 consecutive calendar days of such inspection report.

Page 1-35, Article 104-10 Maintenance of the Project, lines 42-44, replace the last sentence of the last paragraph with the following:

The Contractor will not be directly compensated for any maintenance operations necessary, except for maintenance of guardrail/guiderail, as this work will be considered incidental to the work covered by the various contract items. The provisions of Article 104-7, Extra Work, and Article 104-8, Compensation and Record Keeping will apply to authorized maintenance of guardrail/guiderail. Performance of weekly inspections of guardrail/guiderail, and the damage reports required as described above, will be considered to be an incidental part of the work being paid for by the various contract items.

BID DOCUMENTATION:

(1-1-02) (Rev.8-18-15)

103

SP1 G142

General

The successful Bidder (Contractor) shall submit the original, unaltered bid documentation or a certified copy of the original, unaltered bid documentation used to prepare the bid for this contract to the Department within 10 days after receipt of notice of award of contract. Such documentation shall be placed in escrow with a banking institution or other bonded document storage facility selected by the Department.

The Department will not execute the contract until the original, unaltered bid documentation or a certified copy of the original, unaltered bid documentation has been received by the Department.

Terms

Bid Documentation - Bid Documentation shall mean all written information, working papers, computer printouts, electronic media, charts, and all other data compilations which contain or reflect information, data, and calculations used by the Bidder in the preparation of the bid. The term *bid documentation* includes, but is not limited to, contractor equipment rates, contractor overhead rates, labor rates, efficiency or productivity factors, arithmetical calculations, and quotations from subcontractors and material suppliers to the extent that such rates and quotations were used by the Bidder in formulating and determining the bid. The term *bid documentation* also includes any manuals, which are standard to the industry used by the Bidder in determining the bid. Such manuals may be included in the bid documentation by reference. Such reference shall include the name and date of the publication and the publisher. *Bid Documentation* does not include bid documents provided by the Department for use by the Bidder in bidding on this project. The Bid Documentation can be in the form of electronic submittal (i.e. thumb drive) or paper. If the Bidder elects to submit the Bid Documentation in electronic format, the Department requires a backup submittal (i.e. a second thumb drive) in case one is corrupted.

Contractor's Representative - Officer of the Contractor's company; if not an officer, the Contractor shall supply a letter signed and notarized by an officer of the Contractor's company, granting permission for the representative to sign the escrow agreement on behalf of the Contractor.

Escrow Agent - Officer of the select banking institution or other bonded document storage facility authorized to receive and release bid documentation.

Escrow Agreement Information

A draft copy of the Escrow Agreement will be mailed to the Bidder after the notice of award for informational purposes. The Bidder and Department will sign the actual Escrow Agreement at the time the bid documentation is delivered to the Escrow Agent.

Failure to Provide Bid Documentation

The Bidder's failure to provide the original, unaltered bid documentation or a certified copy of the original, unaltered bid documentation within 10 days after the notice of award is received may be just cause for rescinding the award of the contract and may result in the removal of the Bidder

from the Department's list of qualified bidders for a period of up to 180 days. Award may then be made to the next lowest responsible bidder or the work may be readvertised and constructed under the contract or otherwise, as the Department may decide.

Submittal of Bid Documentation

- (A) Appointment – Email specs@ncdot.gov or call 919.707.6900 to schedule an appointment.
- (B) Delivery - A representative of the Bidder shall deliver the original, unaltered bid documentation or a certified copy of the original, unaltered bid documentation to the Department, in a container suitable for sealing, within 10 days after the notice of award is received.
- (C) Packaging – The container shall be no larger than 15.5 inches in length by 12 inches wide by 11 inches high and shall be water resistant. The container shall be clearly marked on the face and the back of the container with the following information: Bid Documentation, Bidder's Name, Bidder's Address, Date of Escrow Submittal, Contract Number, TIP Number if applicable, and County.

Affidavit

Bid documentation will be considered a certified copy if the Bidder includes an affidavit stating that the enclosed documentation is an EXACT copy of the original documentation used by the Bidder to determine the bid for this project. The affidavit shall also list each bid document with sufficient specificity so a comparison may be made between the list and the bid documentation to ensure that all of the bid documentation listed in the affidavit has been enclosed for escrow. The affidavit shall attest that the affiant has personally examined the bid documentation, that the affidavit lists all of the documents used by the Bidder to determine the bid for this project, and that all bid documentation has been included. The affidavit shall be signed by a chief officer of the company, have the person's name and title typed below the signature, and the signature shall be notarized at the bottom of the affidavit.

Verification

Upon delivery of the bid documentation, the Department's Contract Officer and the Bidder's representative will verify the accuracy and completeness of the bid documentation compared to the affidavit. Should a discrepancy exist, the Bidder's representative shall immediately furnish the Department's Contract Officer with any other needed bid documentation. The Department's Contract Officer upon determining that the bid documentation is complete will, in the presence of the Bidder's representative, immediately place the complete bid documentation and affidavit in the container and seal it. Both parties will deliver the sealed container to the Escrow Agent for placement in a safety deposit box, vault, or other secure accommodation.

Confidentiality of Bid Documentation

The bid documentation and affidavit in escrow are, and will remain, the property of the Bidder. The Department has no interest in, or right to, the bid documentation and affidavit other than to verify the contents and legibility of the bid documentation unless the Contractor gives written notice of intent to file a claim, files a written claim, files a written and verified claim, or initiates litigation against the Department. In the event of such written notice of intent to file a claim, filing of a written claim, filing a written and verified claim, or initiation of litigation against the Department, or receipt of a letter from the Contractor authorizing release, the bid documentation and affidavit may become the property of the Department for use in considering any claim or in litigation as the Department may deem appropriate.

Any portion or portions of the bid documentation designated by the Bidder as a *trade secret* at the time the bid documentation is delivered to the Department's Contract Officer shall be protected from disclosure as provided by *G.S. 132-1.2*.

Duration and Use

The bid documentation and affidavit shall remain in escrow until 60 calendar days from the time the Contractor receives the final estimate; or until such time as the Contractor:

- (A) Gives written notice of intent to file a claim,
- (B) Files a written claim,
- (C) Files a written and verified claim,
- (D) Initiates litigation against the Department related to the contract; or
- (E) Authorizes in writing its release.

Upon the giving of written notice of intent to file a claim, filing a written claim, filing a written and verified claim, or the initiation of litigation by the Contractor against the Department, or receipt of a letter from the Contractor authorizing release, the Department may obtain the release and custody of the bid documentation.

The Bidder certifies and agrees that the sealed container placed in escrow contains all of the bid documentation used to determine the bid and that no other bid documentation shall be relevant or material in litigation over claims brought by the Contractor arising out of this contract.

Release of Bid Documentation to the Contractor

If the bid documentation remains in escrow 60 calendar days after the time the Contractor receives the final estimate and the Contractor has not filed a written claim, filed a written and verified claim, or has not initiated litigation against the Department related to the contract, the Department will instruct the Escrow Agent to release the sealed container to the Contractor.

The Contractor will be notified by certified letter from the Escrow Agent that the bid documentation will be released to the Contractor. The Contractor or his representative shall retrieve the bid documentation from the Escrow Agent within 30 days of the receipt of the certified letter. If the Contractor does not receive the documents within 30 days of the receipt of the certified

letter, the Department will contact the Contractor to determine final dispersion of the bid documentation.

Payment

The cost of the escrow will be borne by the Department. There will be no separate payment for all costs of compilation of the data, container, or verification of the bid documentation. Payment at the various contract unit or lump sum prices in the contract will be full compensation for all such costs.

TWELVE MONTH GUARANTEE:

(7-15-03)

108

SP1 G145

- (A) The Contractor shall guarantee materials and workmanship against latent and patent defects arising from faulty materials, faulty workmanship or negligence for a period of twelve months following the date of final acceptance of the work for maintenance and shall replace such defective materials and workmanship without cost to the Department. The Contractor will not be responsible for damage due to faulty design, normal wear and tear, for negligence on the part of the Department, and/or for use in excess of the design.
- (B) Where items of equipment or material carry a manufacturer's guarantee for any period in excess of twelve months, then the manufacturer's guarantee shall apply for that particular piece of equipment or material. The Department's first remedy shall be through the manufacturer although the Contractor is responsible for invoking the warranted repair work with the manufacturer. The Contractor's responsibility shall be limited to the term of the manufacturer's guarantee. NCDOT would be afforded the same warranty as provided by the Manufacturer.

This guarantee provision shall be invoked only for major components of work in which the Contractor would be wholly responsible for under the terms of the contract. Examples would include pavement structures, bridge components, and sign structures. This provision will not be used as a mechanism to force the Contractor to return to the project to make repairs or perform additional work that the Department would normally compensate the Contractor for. In addition, routine maintenance activities (i.e. mowing grass, debris removal, ruts in earth shoulders,) are not parts of this guarantee.

Appropriate provisions of the payment and/or performance bonds shall cover this guarantee for the project.

To ensure uniform application statewide the Division Engineer will forward details regarding the circumstances surrounding any proposed guarantee repairs to the Chief Engineer for review and approval prior to the work being performed.

OUTSOURCING OUTSIDE THE USA:

(9-21-04) (Rev. 5-16-06)

SP1 G150

All work on consultant contracts, services contracts, and construction contracts shall be performed in the United States of America. No work shall be outsourced outside of the United States of America.

Outsourcing for the purpose of this provision is defined as the practice of subcontracting labor, work, services, staffing, or personnel to entities located outside of the United States.

The North Carolina Secretary of Transportation shall approve exceptions to this provision in writing.

IRAN DIVESTMENT ACT:

(5-17-16)

SP01 G151

As a result of the Iran Divestment Act of 2015 (Act), Article 6E, N.C. General Statute § 147-86.55, the State Treasurer published the Final Divestment List (List) which includes the Final Divestment List-Iran, and the Parent and Subsidiary Guidance-Iran. These lists identify companies and persons engaged in investment activities in Iran and will be updated every 180 days. The List can be found at <https://www.nctreasurer.com/inside-the-department/OpenGovernment/Pages/Iran-Divestment-Act-Resources.aspx>

By submitting the Offer, the Contractor certifies that, as of the date of this bid, it is not on the then-current List created by the State Treasurer. The Contractor must notify the Department immediately if, at any time before the award of the contract, it is added to the List.

As an ongoing obligation, the Contractor must notify the Department immediately if, at any time during the contract term, it is added to the List. Consistent with § 147-86.59, the Contractor shall not contract with any person to perform a part of the work if, at the time the subcontract is signed, that person is on the then-current List.

During the term of the Contract, should the Department receive information that a person is in violation of the Act as stated above, the Department will offer the person an opportunity to respond and the Department will take action as appropriate and provided for by law, rule, or contract.

GIFTS FROM VENDORS AND CONTRACTORS:

(12-15-09)

107-1

SP1 G152

By Executive Order 24, issued by Governor Perdue, and *N.C.G.S. § 133-32*, it is unlawful for any vendor or contractor (i.e. architect, bidder, contractor, construction manager, design professional, engineer, landlord, offeror, seller, subcontractor, supplier, or vendor), to make gifts or to give favors to any State employee of the Governor's Cabinet Agencies (i.e. Administration, Commerce, Correction, Crime Control and Public Safety, Cultural Resources, Environment and Natural Resources, Health and Human Services, Juvenile Justice and Delinquency Prevention, Revenue, Transportation, and the Office of the Governor). This prohibition covers those vendors and contractors who:

- (A) Have a contract with a governmental agency; or
- (B) Have performed under such a contract within the past year; or
- (C) Anticipate bidding on such a contract in the future.

For additional information regarding the specific requirements and exemptions, vendors and contractors are encouraged to review Executive Order 24 and *N.C.G.S. § 133-32*.

Executive Order 24 also encouraged and invited other State Agencies to implement the requirements and prohibitions of the Executive Order to their agencies. Vendors and contractors

should contact other State Agencies to determine if those agencies have adopted Executive Order 24.

LIABILITY INSURANCE:

(5-20-14)

SP1 G160

Revise the *2012 Standard Specifications* as follows:

Page 1-60, Article 107-15 LIABILITY INSURANCE, line 16, add the following as the second sentence of the third paragraph:

Prior to beginning services, all contractors shall provide proof of coverage issued by a workers' compensation insurance carrier, or a certificate of compliance issued by the Department of Insurance for self-insured subcontractors, irrespective of whether having regularly in service fewer than three employees.

EROSION AND SEDIMENT CONTROL/STORMWATER CERTIFICATION:

(1-16-07) (Rev 11-22-16)

105-16, 225-2, 16

SP1 G180

General

Schedule and conduct construction activities in a manner that will minimize soil erosion and the resulting sedimentation and turbidity of surface waters. Comply with the requirements herein regardless of whether or not a National Pollution discharge Elimination System (NPDES) permit for the work is required.

Establish a chain of responsibility for operations and subcontractors' operations to ensure that the *Erosion and Sediment Control/Stormwater Pollution Prevention Plan* is implemented and maintained over the life of the contract.

- (A) *Certified Supervisor* - Provide a certified Erosion and Sediment Control/Stormwater Supervisor to manage the Contractor and subcontractor operations, insure compliance with Federal, State and Local ordinances and regulations, and manage the Quality Control Program.
- (B) *Certified Foreman* - Provide a certified, trained foreman for each construction operation that increases the potential for soil erosion or the possible sedimentation and turbidity of surface waters.
- (C) *Certified Installer* - Provide a certified installer to install or direct the installation for erosion or sediment/stormwater control practices.
- (D) *Certified Designer* - Provide a certified designer for the design of the erosion and sediment control/stormwater component of reclamation plans and, if applicable, for the design of the project erosion and sediment control/stormwater plan.

Roles and Responsibilities

- (A) *Certified Erosion and Sediment Control/Stormwater Supervisor* - The Certified Supervisor shall be Level II and responsible for ensuring the erosion and sediment control/stormwater

plan is adequately implemented and maintained on the project and for conducting the quality control program. The Certified Supervisor shall be on the project within 24 hours notice from initial exposure of an erodible surface to the project's final acceptance. Perform the following duties:

- (1) Manage Operations - Coordinate and schedule the work of subcontractors so that erosion and sediment control/stormwater measures are fully executed for each operation and in a timely manner over the duration of the contract.
 - (a) Oversee the work of subcontractors so that appropriate erosion and sediment control/stormwater preventive measures are conformed to at each stage of the work.
 - (b) Prepare the required National Pollutant Discharge Elimination System (NPDES) Inspection Record and submit to the Engineer.
 - (c) Attend all weekly or monthly construction meetings to discuss the findings of the NPDES inspection and other related issues.
 - (d) Implement the erosion and sediment control/stormwater site plans requested.
 - (e) Provide any needed erosion and sediment control/stormwater practices for the Contractor's temporary work not shown on the plans, such as, but not limited to work platforms, temporary construction, pumping operations, plant and storage yards, and cofferdams.
 - (f) Acquire applicable permits and comply with requirements for borrow pits, dewatering, and any temporary work conducted by the Contractor in jurisdictional areas.
 - (g) Conduct all erosion and sediment control/stormwater work in a timely and workmanlike manner.
 - (h) Fully perform and install erosion and sediment control/stormwater work prior to any suspension of the work.
 - (i) Coordinate with Department, Federal, State and Local Regulatory agencies on resolution of erosion and sediment control/stormwater issues due to the Contractor's operations.
 - (j) Ensure that proper cleanup occurs from vehicle tracking on paved surfaces or any location where sediment leaves the Right-of-Way.
 - (k) Have available a set of erosion and sediment control/stormwater plans that are initialed and include the installation date of Best Management Practices. These practices shall include temporary and permanent groundcover and be properly updated to reflect necessary plan and field changes for use and review by Department personnel as well as regulatory agencies.
- (2) Requirements set forth under the NPDES Permit - The Department's NPDES Stormwater permit (NCS000250) outlines certain objectives and management measures pertaining to construction activities. The permit references *NCG010000, General Permit to Discharge Stormwater* under the NPDES, and states that the Department shall incorporate the applicable requirements into its delegated Erosion and Sediment Control Program for construction activities disturbing one or more acres of land. The Department further incorporates these requirements on all

contracted bridge and culvert work at jurisdictional waters, regardless of size. Some of the requirements are, but are not limited to:

- (a) Control project site waste to prevent contamination of surface or ground waters of the state, i.e. from equipment operation/maintenance, construction materials, concrete washout, chemicals, litter, fuels, lubricants, coolants, hydraulic fluids, any other petroleum products, and sanitary waste.
 - (b) Inspect erosion and sediment control/stormwater devices and stormwater discharge outfalls at least once every 7 calendar days and within 24 hours after a rainfall event of 0.5 inch that occurs within a 24 hour period. Additional monitoring may be required at the discretion of Division of Water Resources personnel if the receiving stream is 303(d) listed for turbidity and the project has had documented problems managing turbidity.
 - (c) Maintain an onsite rain gauge or use the Department's Multi-Sensor Precipitation Estimate website to maintain a daily record of rainfall amounts and dates.
 - (d) Maintain erosion and sediment control/stormwater inspection records for review by Department and Regulatory personnel upon request.
 - (e) Implement approved reclamation plans on all borrow pits, waste sites and staging areas.
 - (f) Maintain a log of turbidity test results as outlined in the Department's Procedure for Monitoring Borrow Pit Discharge.
 - (g) Provide secondary containment for bulk storage of liquid materials.
 - (h) Provide training for employees concerning general erosion and sediment control/stormwater awareness, the Department's NPDES Stormwater Permit NCS000250 requirements, and the applicable requirements of the *General Permit, NCG010000*.
 - (i) Report violations of the NPDES permit to the Engineer immediately who will notify the Division of Water Quality Regional Office within 24 hours of becoming aware of the violation.
- (3) Quality Control Program - Maintain a quality control program to control erosion, prevent sedimentation and follow provisions/conditions of permits. The quality control program shall:
- (a) Follow permit requirements related to the Contractor and subcontractors' construction activities.
 - (b) Ensure that all operators and subcontractors on site have the proper erosion and sediment control/stormwater certification.
 - (c) Notify the Engineer when the required certified erosion and sediment control/stormwater personnel are not available on the job site when needed.
 - (d) Conduct the inspections required by the NPDES permit.
 - (e) Take corrective actions in the proper timeframe as required by the NPDES permit for problem areas identified during the NPDES inspections.
 - (f) Incorporate erosion control into the work in a timely manner and stabilize disturbed areas with mulch/seed or vegetative cover on a section-by-section basis.

- (g) Use flocculants approved by state regulatory authorities where appropriate and where required for turbidity and sedimentation reduction.
- (h) Ensure proper installation and maintenance of temporary erosion and sediment control devices.
- (i) Remove temporary erosion or sediment control devices when they are no longer necessary as agreed upon by the Engineer.
- (j) The Contractor's quality control and inspection procedures shall be subject to review by the Engineer. Maintain NPDES inspection records and make records available at all times for verification by the Engineer.

(B) *Certified Foreman* - At least one Certified Foreman shall be onsite for each type of work listed herein during the respective construction activities to control erosion, prevent sedimentation and follow permit provisions:

- (1) Foreman in charge of grading activities
- (2) Foreman in charge of bridge or culvert construction over jurisdictional areas
- (3) Foreman in charge of utility activities

The Contractor may request to use the same person as the Level II Supervisor and Level II Foreman. This person shall be onsite whenever construction activities as described above are taking place. This request shall be approved by the Engineer prior to work beginning.

The Contractor may request to name a single Level II Foreman to oversee multiple construction activities on small bridge or culvert replacement projects. This request shall be approved by the Engineer prior to work beginning.

(C) *Certified Installers* - Provide at least one onsite, Level I Certified Installer for each of the following erosion and sediment control/stormwater crew:

- (1) Seeding and Mulching
- (2) Temporary Seeding
- (3) Temporary Mulching
- (4) Sodding
- (5) Silt fence or other perimeter erosion/sediment control device installations
- (6) Erosion control blanket installation
- (7) Hydraulic tackifier installation
- (8) Turbidity curtain installation
- (9) Rock ditch check/sediment dam installation
- (10) Ditch liner/matting installation
- (11) Inlet protection
- (12) Riprap placement
- (13) Stormwater BMP installations (such as but not limited to level spreaders, retention/detention devices)
- (14) Pipe installations within jurisdictional areas

If a Level I *Certified Installer* is not onsite, the Contractor may substitute a Level II Foreman for a Level I Installer, provided the Level II Foreman is not tasked to another crew requiring Level II Foreman oversight.

- (D) *Certified Designer* - Include the certification number of the Level III-B Certified Designer on the erosion and sediment control/stormwater component of all reclamation plans and if applicable, the certification number of the Level III-A Certified Designer on the design of the project erosion and sediment control/stormwater plan.

Preconstruction Meeting

Furnish the names of the *Certified Erosion and Sediment Control/Stormwater Supervisor*, *Certified Foremen*, *Certified Installers* and *Certified Designer* and notify the Engineer of changes in certified personnel over the life of the contract within 2 days of change.

Ethical Responsibility

Any company performing work for the North Carolina Department of Transportation has the ethical responsibility to fully disclose any reprimand or dismissal of an employee resulting from improper testing or falsification of records.

Revocation or Suspension of Certification

Upon recommendation of the Chief Engineer to the certification entity, certification for *Supervisor*, *Certified Foremen*, *Certified Installers* and *Certified Designer* may be revoked or suspended with the issuance of an *Immediate Corrective Action (ICA)*, *Notice of Violation (NOV)*, or *Cease and Desist Order* for erosion and sediment control/stormwater related issues.

The Chief Engineer may recommend suspension or permanent revocation of certification due to the following:

- (A) Failure to adequately perform the duties as defined within this certification provision.
- (B) Issuance of an ICA, NOV, or Cease and Desist Order.
- (C) Failure to fully perform environmental commitments as detailed within the permit conditions and specifications.
- (D) Demonstration of erroneous documentation or reporting techniques.
- (E) Cheating or copying another candidate's work on an examination.
- (F) Intentional falsification of records.
- (G) Directing a subordinate under direct or indirect supervision to perform any of the above actions.
- (H) Dismissal from a company for any of the above reasons.
- (I) Suspension or revocation of one's certification by another entity.

Suspension or revocation of a certification will be sent by certified mail to the certificant and the Corporate Head of the company that employs the certificant.

A certificant has the right to appeal any adverse action which results in suspension or permanent revocation of certification by responding, in writing, to the Chief Engineer within 10 calendar days after receiving notice of the proposed adverse action.

Chief Engineer
1536 Mail Service Center
Raleigh, NC 27699-1536

Failure to appeal within 10 calendar days will result in the proposed adverse action becoming effective on the date specified on the certified notice. Failure to appeal within the time specified will result in a waiver of all future appeal rights regarding the adverse action taken. The certificant will not be allowed to perform duties associated with the certification during the appeal process.

The Chief Engineer will hear the appeal and make a decision within 7 days of hearing the appeal. Decision of the Chief Engineer will be final and will be made in writing to the certificant.

If a certification is temporarily suspended, the certificant shall pass any applicable written examination and any proficiency examination, at the conclusion of the specified suspension period, prior to having the certification reinstated.

Measurement and Payment

Certified Erosion and Sediment Control/Stormwater Supervisor, Certified Foremen, Certified Installers and Certified Designer will be incidental to the project for which no direct compensation will be made.

PROCEDURE FOR MONITORING BORROW PIT DISCHARGE:

(2-20-07) (Rev. 3-19-13)

105-16, 230, 801

SP1 G181

Water discharge from borrow pit sites shall not cause surface waters to exceed 50 NTUs (nephelometric turbidity unit) in streams not designated as trout waters and 10 NTUs in streams, lakes or reservoirs designated as trout waters. For lakes and reservoirs not designated as trout waters, the turbidity shall not exceed 25 NTUs. If the turbidity exceeds these levels due to natural background conditions, the existing turbidity level shall not be increased.

If during any operating day, the downstream water quality exceeds the standard, the Contractor shall do all of the following:

- (A) Either cease discharge or modify the discharge volume or turbidity levels to bring the downstream turbidity levels into compliance, or
- (B) Evaluate the upstream conditions to determine if the exceedance of the standard is due to natural background conditions. If the background turbidity measurements exceed the standard, operation of the pit and discharge can continue as long as the stream turbidity levels are not increased due to the discharge.
- (C) Measure and record the turbidity test results (time, date and sampler) at all defined sampling locations 30 minutes after startup and at a minimum, one additional sampling of all sampling locations during that 24-hour period in which the borrow pit is discharging.
- (D) Notify DWQ within 24 hours of any stream turbidity standard exceedances that are not brought into compliance.

During the Environmental Assessment required by Article 230-4 of the *2012 Standard Specifications*, the Contractor shall define the point at which the discharge enters into the State's surface waters and the appropriate sampling locations. Sampling locations shall include points upstream and downstream from the point at which the discharge enters these waters. Upstream sampling location shall be located so that it is not influenced by backwater conditions and represents natural background conditions. Downstream sampling location shall be located at the point where complete mixing of the discharge and receiving water has occurred.

The discharge shall be closely monitored when water from the dewatering activities is introduced into jurisdictional wetlands. Any time visible sedimentation (deposition of sediment) on the wetland surface is observed, the dewatering activity will be suspended until turbidity levels in the stilling basin can be reduced to a level where sediment deposition does not occur. Staining of wetland surfaces from suspended clay particles, occurring after evaporation or infiltration, does not constitute sedimentation. No activities shall occur in wetlands that adversely affect the functioning of a wetland. Visible sedimentation will be considered an indication of possible adverse impacts on wetland use.

The Engineer will perform independent turbidity tests on a random basis. These results will be maintained in a log within the project records. Records will include, at a minimum, turbidity test results, time, date and name of sampler. Should the Department's test results exceed those of the Contractor's test results, an immediate test shall be performed jointly with the results superseding the previous test results of both the Department and the Contractor.

The Contractor shall use the *NCDOT Turbidity Reduction Options for Borrow Pits Matrix*, available at http://www.ncdot.gov/doh/operations/dp_chief_eng/roadside/fieldops/downloads/Files/TurbidityReductionOptionSheet.pdf to plan, design, construct, and maintain BMPs to address water quality standards. Tier I Methods include stilling basins which are standard compensatory BMPs. Other Tier I methods are noncompensatory and shall be used when needed to meet the stream turbidity standards. Tier II Methods are also noncompensatory and are options that may be needed for protection of rare or unique resources or where special environmental conditions exist at the site which have led to additional requirements being placed in the DWQ's 401 Certifications and approval letters, Isolated Wetland Permits, Riparian Buffer Authorization or a DOT Reclamation Plan's Environmental Assessment for the specific site. Should the Contractor exhaust all Tier I Methods on a site exclusive of rare or unique resources or special environmental conditions, Tier II Methods may be required by regulators on a case by case basis per supplemental agreement.

The Contractor may use cation exchange capacity (CEC) values from proposed site borings to plan and develop the bid for the project. CEC values exceeding 15 milliequivalents per 100 grams of soil may indicate a high potential for turbidity and should be avoided when dewatering into surface water is proposed.

No additional compensation for monitoring borrow pit discharge will be paid.

EMPLOYMENT:

(11-15-11) (Rev. 1-17-12)

108, 102

SP1 G184

Revise the *2012 Standard Specifications* as follows:

Page 1-20, Subarticle 102-15(O), delete and replace with the following:

(O) Failure to restrict a former Department employee as prohibited by Article 108-5.

Page 1-65, Article 108-5 Character of Workmen, Methods, and Equipment, line 32, delete all of line 32, the first sentence of the second paragraph and the first word of the second sentence of the second paragraph.

STATE HIGHWAY ADMINISTRATOR TITLE CHANGE:

(9-18-12)

SP1 G185

Revise the *2012 Standard Specifications* as follows:

Replace all references to “State Highway Administrator” with “Chief Engineer”.

SUBLETTING OF CONTRACT:

(11-18-2014)

108-6

SP1 G186

Revise the *2012 Standard Specifications* as follows:

Page 1-66, Article 108-6 Subletting of Contract, line 37, add the following as the second sentence of the first paragraph:

All requests to sublet work shall be submitted within 30 days of the date of availability or prior to expiration of 20% of the contract time, whichever date is later, unless otherwise approved by the Engineer.

Page 1-67, Article 108-6 Subletting of Contract, line 7, add the following as the second sentence of the fourth paragraph:

Purchasing materials for subcontractors is not included in the percentage of work required to be performed by the Contractor. If the Contractor sublets items of work but elects to purchase material for the subcontractor, the value of the material purchased will be included in the total dollar amount considered to have been sublet.

RECEIPT OF PERMITS:

The Contractor's attention is directed to the fact that approval of Environmental Permits is pending, and receipt of final permits is not anticipated before award of the Contract.

No work in jurisdictional areas north of Third Street will be allowed until the permits are received.

PROJECT SPECIAL PROVISIONS**ROADWAY****CLEARING AND GRUBBING - METHOD II:**

(9-17-02) (Rev.8-18-15)

200

SP2 R02A

Perform clearing on this project to the limits established by Method "II" shown on Standard Drawing No. 200.02 of the *2012 Roadway Standard Drawings*. Conventional clearing methods may be used except where permit drawings or conditions have been included in the proposal which require certain areas to be cleared by hand methods.

BURNING RESTRICTIONS:

(7-1-95)

200, 210, 215

SP2 R05

Open burning is not permitted on any portion of the right-of-way limits established for this project. Do not burn the clearing, grubbing or demolition debris designated for disposal and generated from the project at locations within the project limits, off the project limits or at any waste or borrow sites in this county. Dispose of the clearing, grubbing and demolition debris by means other than burning, according to state or local rules and regulations.

TEMPORARY DETOURS:

(7-1-95) (Rev. 11-19-13)

1101

SP2 R30B

Construct temporary detours required on this project in accordance with the typical sections in the plans or as directed.

After the detours have served their purpose, remove the portions deemed unsuitable for use as a permanent part of the project as directed by the Engineer. Salvage and stockpile the aggregate base course removed from the detours at locations within the right of way, as directed by the Engineer, for removal by State Forces. Place pavement and earth material removed from the detour in embankments or dispose of in waste areas furnished by the Contractor.

Aggregate base course and earth material that is removed will be measured and will be paid at the contract unit price per cubic yard for *Unclassified Excavation*. Pavement that is removed will be measured and will be paid at the contract unit price per square yard for *Removal of Existing _____ Pavement*. Pipe culverts removed from the detours remain the property of the Contractor. Pipe culverts that are removed will be measured and will be paid at the contract unit price per linear foot for *Pipe Removal*. Payment for the construction of the detours will be made at the contract unit prices for the various items involved.

Such prices and payments will be full compensation for constructing the detours and for the work of removing, salvaging, and stockpiling aggregate base course; removing pipe culverts; and for placing earth material and pavement in embankments or disposing of earth material and pavement in waste areas.

SHOULDER AND FILL SLOPE MATERIAL:

(5-21-02)

235, 560

SP2 R45 B

Description

Perform the required shoulder and slope construction for this project in accordance with the applicable requirements of Section 560 and Section 235 of the *2012 Standard Specifications*.

Measurement and Payment

When the Contractor elects to obtain material from an area located beneath a proposed fill sections which does not require excavation for any reason other than to generate acceptable shoulder and fill slope material, the work of performing the excavation will be considered incidental to the item of *Borrow Excavation* or *Shoulder Borrow*. If there is no pay item for *Borrow* or *Shoulder Borrow* in the contract, this work will be considered incidental to *Unclassified Excavation*. Stockpile the excavated material in a manner to facilitate measurement by the Engineer. Fill the void created by the excavation of the shoulder and fill slope material with suitable material. Payment for material used from the stockpile will be made at the contract unit price for *Borrow Excavation* or *Shoulder Borrow*. If there is no pay item for *Borrow Excavation* or *Shoulder Borrow*, then the material will be paid for at the contract unit price for *Unclassified Excavation*. The material used to fill the void created by the excavation of the shoulder and fill slope material will be made at the contract unit price for *Unclassified Excavation*, *Borrow Excavation*, or *Shoulder Borrow*, depending on the source of the material.

Material generated from undercut excavation, unclassified excavation or clearing and grubbing operations that is placed directly on shoulders or slope areas, will not be measured separately for payment, as payment for the work requiring the excavation will be considered adequate compensation for depositing and grading the material on the shoulders or slopes.

When undercut excavation is performed at the direction of the Engineer and the material excavated is found to be suitable for use as shoulder and fill slope material, and there is no area on the project currently prepared to receive the material generated by the undercut operation, the Contractor may construct a stockpile for use as borrow at a later date. Payment for the material used from the stockpile will be made at the contract unit price for *Borrow Excavation* or *Shoulder Borrow*.

When shoulder material is obtained from borrow sources or from stockpiled material, payment for the work of shoulder construction will be made at the contract unit price per cubic yard for *Borrow Excavation* or *Shoulder Borrow* in accordance with the applicable provisions of Section 230 or Section 560 of the *2012 Standard Specifications*.

COAL COMBUSTION PRODUCTS IN EMBANKMENTS:

(4-16-02) (Rev. 5-19-15)

235

SP02 R70

Description

This specification allows the Contractor an option, with the approval of the Engineer, to use coal combustion products (CCPs) in embankments as a substitute for conventional borrow material. The amount of CCPs allowed to be used for this project will be less than 80,000 tons total and less than 8,000 tons per acre.

Materials

Supply coal combustion products from the Department list of potential suppliers maintained by the Value Management Unit. Site specific approval of CCP material will be required prior to beginning construction.

The following CCPs are unacceptable:

- (A) Frozen material,
- (B) Ash from boilers fired with both coal and petroleum coke, and
- (C) Material with a maximum dry unit weight of less than 65 pounds per cubic foot when tested in accordance with AASHTO T-99 Method A or C.

Collect and transport CCPs in a manner that will prevent nuisances and hazards to public health and safety. Moisture condition the CCPs as needed and transport in covered trucks to prevent dusting.

Preconstruction Requirements

When CCPs are to be used as a substitute for earth borrow material, request written approval from the Engineer at least ninety (90) days in advance of the intent to use CCPs and include the following details using the NCDOT Form #CCP-2015-V1 in accordance with NCGS § 130A-309.215(b)(1):

- (A) Description, purpose and location of project.
- (B) Estimated start and completion dates of project.
- (C) Estimated volume of CCPs to be used on project with specific locations and construction details of the placement.
- (D) Toxicity Characteristic Leaching Procedure analysis from a representative sample of each different CCP source to be used in the project for, at minimum, all of the following constituents: arsenic, barium, cadmium, lead, chromium, mercury, selenium, and silver.
- (E) The names, address, and contact information for the generator of the CCPs.
- (F) Physical location of the project at which the CCPs were generated.

Submit the form to the Engineer and the State Value Management Engineer at valuemanagementunit@ncdot.gov for review. The Engineer and the State Value Management Engineer will coordinate the requirements of NCGS § 130A-309.215(a)(1) and notify the Contractor that all the necessary requirements have been met before the placement of structural fill using coal combustion products is allowed.

Construction Methods

In accordance with the detail in the plans, place CCPs in the core of the embankment section with at least 4 feet of earth cover to the outside limits of the embankments or subgrade and at least 5 feet above the seasonal high ground-water table. CCPs used in embankments shall not be placed as follows:

- (A) Within 50 feet of any property boundary.

- (B) Within 300 horizontal feet of a private dwelling or well.
- (C) Within 50 horizontal feet of the top of the bank of a perennial stream or other surface water body.
- (D) Within a 100-year floodplain except as authorized under NCGS § 143-215.54A(b). A site located in a floodplain shall not restrict the flow of the 100-year floodplain or result in washout of solid waste so as to pose a hazard to human life, wildlife or land and water resources.
- (E) Within 50 horizontal feet of a wetland, unless, after consideration of the chemical and physical impact on the wetland, the United States Army Corps of Engineers issues a permit or waiver for the fill.

Construct embankments by placing CCPs in level uniform lifts with no more than a lift of 10 inches and compacted to at least a density of 95 percent as determined by test methods in AASHTO T-99, Determination of Maximum Dry Density and Optimum Moisture Content, Method A or C depending upon particle size of the product. Provide a moisture content at the time of compaction of within 4 percent of optimum but not greater than one percent above optimum as determined by AASHTO T-99, Method A or C.

Divert surface waters resulting from precipitation from the CCPs placement area during filling and construction activities. Construct embankments such that rainfall will not run directly off of the CCPs. Provide dust control to minimize airborne emissions. Construct fill in a manner that prevents water from accumulating and ponding and do not pump nor discharge waters from CCP's filling and construction areas.

Measurement and Payment

Borrow Excavation will be measured by truck volume and paid in cubic yards in accordance with Article 230-5 of the *2012 Standard Specifications*.

MANUFACTURED QUARRY FINES IN EMBANKMENTS:

(01-17-17)

235

SP02 R72

Description

This specification addresses the use of manufactured quarry fines that are not classified as select materials. The specification allows the Contractor an option, with the approval of the Engineer, to use manufactured quarry fines (MQFs) in embankments as a substitute for conventional borrow material. Furnish and place geotextile for pavement stabilization in accordance with the Geotextile for Pavement Stabilization special provision and detail. Geotextile for pavement stabilization is required to prevent pavement cracking and provide separation between the subgrade and pavement section at embankment locations where manufactured quarry fines are utilized and as directed by the Engineer.

Materials

Manufactured Quarry Fines.

Site specific approval of MQFs material will be required prior to beginning construction as detailed in the preconstruction requirements of this provision.

The following MQFs are unacceptable:

- (A) Frozen material,

- (B) Material with a maximum dry unit weight of less than 90 pounds per cubic foot when tested in accordance with AASHTO T-99 Method A or C.
- (C) Material with greater than 80% by weight Passing the #200 sieve

Collect and transport MQFs in a manner that will prevent nuisances and hazards to public health and safety. Moisture condition the MQFs as needed and transport in covered trucks to prevent dusting. If MQFs are blended with natural earth material, follow Borrow Criteria in Section 1018 of the *Standard Specifications*.

Geotextiles.

Areas of embankment where MQFs are incorporated, Geotextile for Pavement Stabilization shall be used. If the Geotextile for Pavement Stabilization special provision is not included elsewhere in this contract, then it along with a detail will be incorporated as part of the contractors request to use. Notification of subgrade elevation, sampling and waiting period as required in the Construction Methods section of the Geotextile for Pavement Stabilization special provision are not required.

Preconstruction Requirements

When MQFs are to be used as a substitute for earth borrow material, request written approval from the Engineer at least ninety (90) days in advance of the intent to use MQFs and include the following details:

- (A) Description, purpose and location of project.
- (B) Estimated start and completion dates of project.
- (C) Estimated volume of MQFs to be used on project with specific locations and construction details of the placement.
- (D) The names, address, and contact information for the generator of the MQFs.
- (E) Physical location of the site at which the MQFs were generated.

The Engineer will forward this information to the State Materials Engineer for review and material approval.

Construction Methods

Place MQFs in the core of the embankment section with at least 4 feet of earth cover to the outside limits of the embankments or subgrade.

Construct embankments by placing MQFs in level uniform lifts with no more than a lift of 10 inches and compacted to at least a density of 95 percent as determined by test methods in AASHTO T-99, Determination of Maximum Dry Density and Optimum Moisture Content, Method A or C depending upon particle size of the product. Provide a moisture content at the time of compaction of within 4 percent of optimum but not greater than one percent above optimum as determined by AASHTO T-99, Method A or C.

Areas of embankment where MQFs are incorporated, Geotextile for Pavement Stabilization shall be used. See Geotextile for Pavement Stabilization special provision for geotextile type and construction method.

Measurement and Payment

Borrow Excavation will be measured by truck volume and paid in cubic yards in accordance with Article 230-5 of the *2012 Standard Specifications*. As an alternate weigh tickets can be provided and payment made by converting weight to cubic yards based on the verifiable unit weight. Where the pay item of *Geotextile for Pavement Stabilization* is included in the original contract the material will be measured and paid in square yards (see *Geotextile for Pavement Stabilization* special provision). Where the pay item of *Geotextile for Pavement Stabilization* is not included in the original contract then no payment will be made for this item and will be considered incidental to the use of MQFs in embankment.

ROCK AND BROKEN PAVEMENT FILLS:

(2-16-16)

235

SP2 R85

Revise the *2012 Standard Specifications* as follows:

Page 2-22, Article 235-2 MATERIALS, add the following after line 19:

| Item | Section |
|---|----------------|
| Geotextile for Rock and Broken Pavement Fills, Type 2 | 1056 |

Provide Type 2 geotextile for filtration geotextiles. Use rip rap and No. 57 stone from either a quarry or onsite material to fill voids in rock and broken pavement fills. Provide small and large size rip rap with stone sizes that meet Class A and B in accordance with Table 1042-1 and No. 57 stone with a gradation that meets Table 1005-1 or use similar size onsite material approved by the Engineer.

Page 2-23, Subarticle 235-3(B) Embankment Formation, lines 18-19, delete the third sentence in the seventh paragraph.

Page 2-23, Subarticle 235-3(B) Embankment Formation, lines 21-23, replace the eighth paragraph with the following:

Before placing embankment fill material or filtration geotextiles over rock and broken pavement, fill voids in the top of rock and broken pavement fill with rip rap and No. 57 stone. Place and compact larger rip rap first followed by smaller rip rap. Then, fill any remaining voids with No. 57 stone so geotextiles are not torn, ripped or otherwise damaged when installed and covered. Compact rip rap and No. 57 stone with tracked equipment or other approved methods. Install filtration geotextiles on top of rock, broken pavement, rip rap and No. 57 stone in accordance with Article 270-3 before placing remaining embankment fill material.

Remove any rocks, debris or pavement pieces from the roadbed larger than 2" within 12" of the subgrade or finished grade, whichever is lower.

Page 2-24, Article 235-5 MEASUREMENT AND PAYMENT, line 13, add the following to the end of the first paragraph:

Payment for rip rap, No. 57 stone and geotextiles to construct embankments with rock and broken pavement fills will be considered incidental to the work in Sections 225, 226, 230 and 240.

BLASTING:

(2-16-16)

220

SP2 R88B

Revise the *2012 Standard Specifications* as follows:

Page 2-8, Article 220-1 DESCRIPTION, line 22, delete “cushion, ”.

Page 2-8, Article 220-1 DESCRIPTION, line 23, add the following after the third sentence:

Unless required otherwise in the contract, design blasts for the vibration and air overpressure limits in this section.

Page 2-9, Subarticle 220-3(A) Vibration and Air Overpressure Limits, line 18, add the following to the end of Subarticle 220-3(A):

Unless required otherwise in the contract or directed, design production and trench blasts in accordance with the following:

- (1) Production Blasting
 - (a) For rock cut slopes steeper than 1.5:1 (H:V) without pre-splitting, do not use production blast holes more than 4" in diameter within 10 ft of finished slope faces or neat lines
 - (b) Do not drill production holes below bottom of adjacent pre-split blast holes
 - (c) Use delay blasting to detonate production blast holes towards a free face
- (2) Trench Blasting
 - (a) Do not use trench blast holes more than 3" in diameter
 - (b) Do not use ANFO or other bulk loaded products
 - (c) Use cartridge explosives or other explosive types designed for trench blasting
 - (d) Use charges with a diameter of 1/2" to 3/4" less than the trench blast hole diameter

HAZARDOUS SPILL BASIN:

12-17-09

SPI 8-31 (Revised)

Description

The Contractor shall construct hazardous spill basins at locations indicated in the plans, in accordance with the detail and contract documents and as directed by the Engineer.

Construction

Construct the headwall and sluice gate in accordance with Standard 838.02 of the Roadway Standard Drawings.

Install pipe in accordance with the contract documents.

Perform earthwork in accordance with the contract documents.

Place rip rap and geotextile for drainage in accordance with the contract documents.

Measurement and Payment

Endwalls will be measured and paid for in accordance with Section 838 of the *Standard Specifications*.

Pipe will be measured and paid for in accordance with the contract documents.

___” *Sluice Gate* will be measured and paid in accordance with the contract document.

Rip Rap, Class B will be measured and paid for in accordance with Section 876 of the *Standard Specifications*.

Geotextile For Drainage will be measured and paid for in accordance with Section 876 of the *Standard Specifications*.

Drainage Ditch Excavation will be measured and paid for in accordance with Section 240 of the *Standard Specifications*.

Borrow Excavation will be measured and paid for in accordance with Section 230 of the *Standard Specifications*.

PIPE INSTALLATION:

(11-20-12) (Rev. 8-18-15)

300

SP3 R01

Revise the 2012 *Standard Specifications* as follows:

Page 3-1, Article 300-2, Materials, line 15, in the materials table, replace “Flowable Fill” and “Geotextiles” with the following:

| Item | Section |
|----------------------------|----------------|
| Flowable Fill, Excavatable | 1000-6 |
| Grout, Type 2 | 1003 |
| Geotextiles, Type 4 | 1056 |

Page 3-1, Article 300-2, Materials, lines 23-24, replace sentence with the following:

Provide foundation conditioning geotextile and geotextile to wrap pipe joints in accordance with Section 1056 for Type 4 geotextile.

Page 3-3, Subarticle 300-6(A), Rigid Pipe, line 2, in the first paragraph, replace “an approved non-shrink grout.” with “grout.” and line 4, in the second paragraph, replace “filtration geotextile” with “geotextile”.

Page 3-3, Article 300-7, Backfilling, lines 37-38, in the first and second sentences of the fifth paragraph, replace “Excavatable flowable fill” with “Flowable fill”.

FLOWABLE FILL:

(9-17-02) (Rev 1-17-12)

300, 340, 1000, 1530, 1540, 1550

SP3 R30

Description

This work consists of all work necessary to place flowable fill in accordance with these provisions, the plans, and as directed.

Materials

Refer to Division 10 of the *2012 Standard Specifications*.

Item

Flowable Fill

Section

1000-6

Construction Methods

Discharge flowable fill material directly from the truck into the space to be filled, or by other approved methods. The mix may be placed full depth or in lifts as site conditions dictate. The Contractor shall provide a method to plug the ends of the existing pipe in order to contain the flowable fill.

Measurement and Payment

At locations where flowable fill is called for on the plans and a pay item for flowable fill is included in the contract, *Flowable Fill* will be measured in cubic yards and paid as the actual number of cubic yards that have been satisfactorily placed and accepted. Such price and payment will be full compensation for all work covered by this provision including, but not limited to, the mix design, furnishing, hauling, placing and containing the flowable fill.

Payment will be made under:

Pay Item

Flowable Fill

Pay Unit

Cubic Yard

BRIDGE APPROACH FILLS:

(10-19-10) (Rev. 1-17-12)

422

SP4 R02

Description

Bridge approach fills include bridge approach fills for sub regional tier bridges and reinforced bridge approach fills. Construct bridge approach fills in accordance with the contract and Standard Drawing No. 422.10 or 422.11 of the *2012 Roadway Standard Drawings*. Define “geosynthetics” as geotextiles or geomembranes.

Materials

Refer to Division 10 of the *2012 Standard Specifications*.

| Item | Section |
|-------------------------------|----------------|
| Anchor Pins | 1056-2 |
| Geotextiles | 1056 |
| Portland Cement Concrete | 1000 |
| Select Material | 1016 |
| Subsurface Drainage Materials | 1044 |
| Wire Staples | 1060-8(D) |

For bridge approach fills for sub regional tier bridges, provide Type 1 geotextile for filtration geotextiles. For reinforced bridge approach fills, provide Type 5 geotextile for geotextile reinforcement and Type 1 geotextile and No. 78M stone for drains. Use Class B concrete for concrete pads.

Use Class III or V select material for reinforced bridge approach fills and only Class V select material (standard size No. 78M stone) for bridge approach fills for sub regional tier bridges. Provide PVC pipes, fittings and outlet pipes for subsurface drainage materials. For drains and PVC pipes behind end bents, use pipes with perforations that meet AASHTO M 278.

Use PVC, HDPE or linear low density polyethylene (LLDPE) geomembranes for reinforced bridge approach fills. For PVC geomembranes, provide grade PVC30 geomembranes that meet ASTM D7176. For HDPE and LLDPE geomembranes, use geomembranes with a nominal thickness of at least 30 mils that meet Geosynthetic Research Institute Standard Specifications GM13 or GM17, respectively. Handle and store geomembranes in accordance with Article 1056-2 of the *2012 Standard Specifications*. Provide material certifications for geomembranes in accordance with Article 1056-3 of the *2012 Standard Specifications*.

Construction Methods

Excavate as necessary for bridge approach fills in accordance with the contract. Notify the Engineer when foundation excavation is complete. Do not place geomembranes or filtration geotextiles until excavation dimensions and foundation material are approved. Attach geomembranes and filtration geotextiles to end bent cap back and wing walls with adhesives, tapes or other approved methods. Glue or weld geomembrane seams to prevent leakage.

For reinforced bridge approach fills, place geotextile reinforcement within 3" of locations shown in Standard Drawing No. 422.10 of the *2012 Roadway Standard Drawings* and in slight tension free of kinks, folds, wrinkles or creases. Install geotextile reinforcement with the orientation, dimensions and number of layers shown in Standard Drawing No. 422.10 of the *2012 Roadway Standard Drawings*. Place first layer of geotextile reinforcement directly on geomembranes with no void or material in between. Install geotextile reinforcement with the machine direction (MD) parallel to the roadway centerline. The MD is the direction of the length or long dimension of the geotextile roll. Do not splice or overlap geotextile reinforcement in the MD so seams are perpendicular to the roadway centerline. Wrap geotextile reinforcement at end bent cap back and wing walls as shown in Standard Drawing No. 422.10 of the *2012 Roadway Standard Drawings* and directed by the Engineer. Extend geotextile reinforcement at least 4 ft back behind end bent cap back and wing walls into select material.

Overlap adjacent geotextiles at least 18" with seams oriented parallel to the roadway centerline. Hold geotextiles in place with wire staples or anchor pins as needed. Contact the Engineer when existing or future obstructions such as foundations, pavements, pipes, inlets or utilities will interfere with geosynthetics.

For reinforced bridge approach fills, construct one foot square drains consisting of 4" diameter continuous perforated PVC pipes surrounded by No. 78M stone wrapped in Type 1 geotextiles. Install drains in accordance with Standard Drawing No. 422.10 of the *2012 Roadway Standard Drawings*. For bridge approach fills for sub regional tier bridges, install 4" diameter continuous perforated PVC drain pipes in accordance with Standard Drawing No. 422.11 of the *2012 Roadway Standard Drawings*.

Use solvent cement to connect PVC pipes so joints do not leak. Connect perforated pipes to outlet pipes just behind wing walls. Provide drain pipes and drains with positive drainage towards outlets. Place pipe sleeves in or under wing walls for outlet pipes so positive drainage is maintained. Use sleeves that can withstand wing wall loads.

Place select material in 8" to 10" thick lifts. Use only hand operated compaction equipment to compact select material for bridge approach fills. Compact Class III select material in accordance with Subarticle 235-3(C) of the *2012 Standard Specifications*. Compact No. 78M stone with a vibratory compactor to the satisfaction of the Engineer. Do not displace or damage geosynthetics, drain pipes or drains when placing and compacting select material. End dumping directly on geosynthetics is not permitted. Do not operate heavy equipment on geosynthetics, drain pipes or drains until they are covered with at least 8" of select material. Replace any damaged geosynthetics, drain pipes or drains to the satisfaction of the Engineer.

Cover open ends of outlet pipes with rodent screens as shown in Standard Drawing No. 815.03 of the *2012 Roadway Standard Drawings*. Connect ends of outlet pipes to concrete pads or existing drainage structures as directed by the Engineer. Construct concrete pads with an Ordinary surface finish that meets Subarticle 825-6(B) of the *2012 Standard Specifications*.

Measurement and Payment

Reinforced Bridge Approach Fill, Station ____ will be paid at the contract lump sum price. The contract lump sum price for *Reinforced Bridge Approach Fill, Station ____* will be full compensation for labor, tools, equipment and reinforced bridge approach fill materials, excavating, backfilling, hauling and removing excavated materials, compacting select material, connecting outlet pipes to existing drainage structures and supplying select materials, geosynthetics, drains, pipe sleeves and outlet components and any incidentals necessary to construct all reinforced bridge approach fills at each bridge.

Bridge Approach Fill - Sub Regional Tier, Station ____ will be paid at the contract lump sum price. The contract lump sum price for *Bridge Approach Fill - Sub Regional Tier, Station ____* will be full compensation for labor, tools, equipment and bridge approach fill materials, excavating, backfilling, hauling and removing excavated materials, compacting No. 78M stone, connecting outlet pipes to existing drainage structures and supplying No. 78M stone, filtration geotextiles, drain pipes, pipe sleeves and outlet components and any incidentals necessary to construct all bridge approach fills at each sub regional tier bridge.

Payment will be made under:

Pay Item

Reinforced Bridge Approach Fill, Station ____
 Bridge Approach Fill - Sub Regional Tier, Station ____

Pay Unit

Lump Sum
 Lump Sum

PREPARATION OF SUBGRADE AND BASE:

(1-16-96)

610

SP5 R05

On mainline portions and ramps of this project, prepare the subgrade and base beneath the pavement structure in accordance with the applicable sections of the *2012 Standard Specifications* except use an automatically controlled fine grading machine using string lines, laser controls or other approved methods to produce final subgrade and base surfaces meeting the lines, grades and cross sections required by the plans or established by the Engineer.

No direct payment will be made for the work required by this provision as it will be considered incidental to other work being paid for by the various items in the contract.

CLASS IV SUBGRADE STABILIZATION IN LIEU OF CHEMICAL STABILIZATION:

(6-16-15)

501, 542

SP05 R017

Description

In lieu of chemical stabilization, provide Class IV Subgrade Stabilization by replacing 8" of subgrade soils with geotextile and Class IV select material. This substitution is allowed in full typical section width and cannot result in chemically stabilized sections less than 1,000 feet in length, unless otherwise approved by the Engineer. Notify the Engineer at least 30 days in advance of starting Class IV Subgrade Stabilization in lieu of Chemical Stabilization.

Materials

Refer to the *2012 Standard Specifications*.

| Item | Section |
|---|----------------|
| Geotextile for Soil Stabilization, Type 4 | 1056 |
| Select Material, Class IV | 1016 |

Use Class IV Select Material for Class IV Subgrade Stabilization.

Construction Methods

Install geotextile for soil stabilization in accordance with Article 270-3 in the *2012 Standard Specifications*. Place Class IV subgrade stabilization (standard size no. ABC) by end dumping ABC on geotextiles. Do not operate heavy equipment on geotextiles until geotextiles are covered with Class IV subgrade stabilization. Compact ABC to 97% of AASHTO T 180 as modified by the Department.

Maintain Class IV subgrade stabilization in an acceptable condition and minimize the use of heavy equipment on ABC in order to avoid damaging aggregate subgrades. Provide and maintain drainage ditches and drains as required to prevent entrapping water in aggregate subgrades.

Measurement and Payment

Class IV Subgrade Stabilization in Lieu of Chemical Stabilization will be paid at the prices established in the contract that relate to the chemical stabilization type that is being replaced (Lime or Cement). No direct payment will be made for additional excavation required to accommodate this alternate.

The total amount paid for this subgrade stabilization alternative will be limited to the contract amounts per square yard for replacement for Portland cement or lime, theoretical tons of Portland cement or lime replaced, mixing of cement or lime, and theoretical gallons of asphalt curing seal replaced at the rate of 0.15 gallons per square yard.

A Supplement Agreement will be executed prior to starting the work to create a square yard price for the *Class IV Subgrade Stabilization in Lieu of Chemical Stabilization* and deleting the quantities associated with the work being replaced.

ASPHALT PAVEMENTS - SUPERPAVE:

(6-19-12) (Rev. 8-16-16)

605, 609, 610, 650

SP6 R01

Revise the *2012 Standard Specifications* as follows:

Page 6-3, Article 605-7, APPLICATION RATES AND TEMPERATURES, replace this article, including Table 605-1, with the following:

Apply tack coat uniformly across the existing surface at target application rates shown in Table 605-1.

| Existing Surface | Target Rate (gal/sy) |
|----------------------------|----------------------|
| | Emulsified Asphalt |
| New Asphalt | 0.04 ± 0.01 |
| Oxidized or Milled Asphalt | 0.06 ± 0.01 |
| Concrete | 0.08 ± 0.01 |

Apply tack coat at a temperature within the ranges shown in Table 605-2. Tack coat shall not be overheated during storage, transport or at application.

| Asphalt Material | Temperature Range |
|----------------------------------|-------------------|
| Asphalt Binder, Grade PG 64-22 | 350 - 400°F |
| Emulsified Asphalt, Grade RS-1H | 130 - 160°F |
| Emulsified Asphalt, Grade CRS-1 | 130 - 160°F |
| Emulsified Asphalt, Grade CRS-1H | 130 - 160°F |
| Emulsified Asphalt, Grade HFMS-1 | 130 - 160°F |
| Emulsified Asphalt, Grade CRS-2 | 130 - 160°F |

Page 6-6, Subarticle 607-5(A), Milled Asphalt Pavement, line 25, add the following to the end of the paragraph:

Areas to be paid under these items include mainline, turn lanes, shoulders, and other areas milled in conjunction with the mainline and any additional equipment necessary to remove pavement in the area of manholes, water valves, curb, gutter and other obstructions.

Page 6-6, Subarticle 607-5(C), Incidental Milling, lines 42-48, replace the paragraph with the following:

Incidental Milling to be paid will be the actual number of square yards of surface milled where the Contractor is required to mill butt joints, irregular areas and intersections milled as a separate operation from mainline milling and re-mill areas that are not due to the Contractor's negligence whose length is less than 100 feet. Measurement will be made as provided in Subarticle 607-5(A) for each cut the Contractor is directed to perform. Where the Contractor elects to make multiple cuts to achieve the final depth, no additional measurement will be made. Compensation will be made at the contract unit price per square yard for *Incidental Milling*.

Page 6-7, Article 609-3, FIELD VERIFICATION OF MIXTURE AND JOB MIX FORMULA ADJUSTMENTS, lines 35-37, delete the second sentence of the second paragraph.

Page 6-18, Article 610-1 DESCRIPTION, lines 40-41, delete the last sentence of the last paragraph.

Page 6-19, Subarticle 610-3(A), Mix Design-General, line 5, add the following as the first paragraph:

Warm mix asphalt (WMA) is allowed for use at the Contractor's option in accordance with the NCDOT Approved Products List for WMA Technologies available at:

<https://connect.ncdot.gov/resources/Materials/MaterialsResources/Warm%20Mix%20Asphalt%20Approved%20List.pdf>

Page 6-20, Subarticle 610-3(C), Job Mix Formula (JMF), lines 47-48, replace the last sentence of the third paragraph with the following:

The JMF mix temperature shall be within the ranges shown in Table 610-1 unless otherwise approved.

Page 6-21, Subarticle 610-3(C) Job Mix Formula (JMF), replace Table 610-1 with the following:

| TABLE 610-1 MIXING TEMPERATURE AT THE ASPHALT PLANT | |
|--|----------------------------|
| Binder Grade | JMF Mix Temperature |
| PG 58-28; PG 64-22 | 250 - 290°F |
| PG 70-22 | 275- 305°F |
| PG 76-22 | 300- 325°F |

Page 6-21, Subarticle 610-3(C) Job Mix Formula (JMF), lines 1-2, in the first sentence of the first paragraph, delete "and compaction". Lines 4-7, delete the second paragraph and replace with the following:

When RAS is used, the JMF mix temperature shall be established at 275°F or higher.

Page 6-22, Article 610-4, WEATHER, TEMPERATURE AND SEASONAL LIMITATIONS FOR PRODUCING AND PLACING ASPHALT MIXTURES, lines 15-17, replace the second sentence of the first paragraph with the following:

Do not place asphalt material when the air or surface temperatures, measured at the location of the paving operation away from artificial heat, do not meet Table 610-5.

Page 6-23, Article 610-4, WEATHER, TEMPERATURE AND SEASONAL LIMITATIONS FOR PRODUCING AND PLACING ASPHALT MIXTURES, replace Table 610-5 with the following:

| TABLE 610-5 PLACEMENT TEMPERATURES FOR ASPHALT | |
|---|--|
| Asphalt Concrete Mix Type | Minimum Surface and Air Temperature |
| B25.0B, C | 35°F |
| I19.0B, C, D | 35°F |
| SF9.5A, S9.5B | 40°F ^A |
| S9.5C, S12.5C | 45°F ^A |
| S9.5D, S12.5D | 50°F |

- A. For the final layer of surface mixes containing recycled asphalt shingles (RAS), the minimum surface and air temperature shall be 50°F.

Page 6-23, Subarticle 610-5(A), General, lines 33-34, replace the last sentence of the third paragraph with the following:

Produce the mixture at the asphalt plant within ± 25 °F of the JMF mix temperature. The temperature of the mixture, when discharged from the mixer, shall not exceed 350°F.

Page 6-26, Article 610-7, HAULING OF ASPHALT MIXTURE, lines 22-23, in the fourth sentence of the first paragraph replace “so as to overlap the top of the truck bed and” with “to”. Line 28, in the last paragraph, replace “+15 °F to -25 °F of the specified JMF temperature.” with “ ± 25 °F of the specified JMF mix temperature.”

Page 6-26, Article 610-8, SPREADING AND FINISHING, line 34, add the following new paragraph:

As referenced in Section 9.6.3 of the *HMA/QMS Manual*, use the automatic screed controls on the paver to control the longitudinal profile. Where approved by the Engineer, the Contractor has the option to use either a fixed or mobile string line.

Page 6-29, Article 610-13, FINAL SURFACE TESTING AND ACCEPTANCE, line 39, add the following after the first sentence in the first paragraph:

Smoothness acceptance testing using the inertial profiler is not required on ramps, loops and turn lanes.

Page 6-30, Subarticle 610-13(A), Option 1 – Inertial Profiler, lines 15-16, replace the fourth sentence of the fourth paragraph with the following:

The interval at which relative profile elevations are reported shall be 2”.

Page 6-30, Subarticle 610-13(A), Option 1 – Inertial Profiler, lines 25-28, replace the ninth paragraph with the following:

Operate the profiler at any speed as per the manufacturer’s recommendations to collect valid data.

Page 6-30, Subarticle 610-13(A), Option 1 – Inertial Profiler, lines 30-31, delete the third sentence of the tenth paragraph.

Page 6-31, Subarticle 610-13(A), Option 1 – Inertial Profiler, lines 11-13, replace the first sentence of the third paragraph with the following:

After testing, transfer the profile data from the profiler portable computer’s hard drive to a write once storage media (Flash drive, USB, DVD-R or CD-R) or electronic media approved by the Engineer.

Page 6-31, Subarticle 610-13(A), Option 1 – Inertial Profiler, lines 17-18, replace the first sentence of the fourth paragraph with the following:

Submit a report with the documentation and electronic data of the evaluation for each section to the Engineer within 10 days after completion of the smoothness testing. The report shall be in the tabular format for each 0.10 segment or a portion thereof with a summary of the MRI values and the localized roughness areas including corresponding project station numbers or acceptable reference points. Calculate the pay adjustments for all segments in accordance with the formulas in Sections (1) and (2) shown below. The Engineer shall review and approval all pay adjustments unless corrective action is required.

Page 6-31, Subarticle 610-13(A)(1), Acceptance for New Construction, lines 36-37, replace the third paragraph with the following:

The price adjustment will apply to each 0.10-mile section or prorated for a portion thereof, based on the Mean Roughness Index (MRI), the average IRI values from both wheel paths.

Page 6-32, Subarticle 610-13(A)(2), Localized Roughness, lines 12-16, replace the first paragraph with the following:

Areas of localized roughness shall be identified through the “Smoothness Assurance Module (SAM)” provided in the ProVAL software. Use the SAM report to optimize repair strategies by analyzing the measurements from profiles collected using inertial profilers. The ride quality threshold for localized roughness shall be 165 in/mile for any sections that are 15 ft. to 100 ft. in length at the continuous short interval of 25 ft. Submit a continuous roughness report to identify each section with project station numbers or reference points outside the threshold and identify all localized roughness, with the signature of the Operator included with the submitted IRI trace and electronic files.

Page 6-32, Subarticle 610-13(A)(2), Localized Roughness, line 21, add the following new paragraph:

If the Engineer does not require corrective action, the pay adjustment for each area of localized roughness shall be based on the following formula:

$$PA = (165 - LR\#) 5$$

Where:

| | | |
|-----|---|--|
| PA | = | Pay Adjustment (dollars) |
| LR# | = | The Localized Roughness number determined from SAM report for the ride quality threshold |

Page 6-41, Subarticle 650-3(B), Mix Design Criteria, replace Table 650-1 with the following:

| <i>Sieve Size (mm)</i> | <i>Type FC-1</i> | <i>Type FC-1 Modified</i> | <i>Type FC-2 Modified</i> |
|------------------------|------------------|---------------------------|---------------------------|
| 19.0 | - | - | 100 |
| 12.5 | 100 | 100 | 80 - 100 |
| 9.50 | 75 - 100 | 75 - 100 | 55 - 80 |
| 4.75 | 25 - 45 | 25 - 45 | 15 - 30 |
| 2.36 | 5 - 15 | 5 - 15 | 5 - 15 |
| 0.075 | 1.0 - 3.0 | 1.0 - 3.0 | 2.0 - 4.0 |

ASPHALT BINDER CONTENT OF ASPHALT PLANT MIXES:

(11-21-00) (Rev. 7-17-12)

609

SP6 R15

The approximate asphalt binder content of the asphalt concrete plant mixtures used on this project will be as follows:

| | | |
|--------------------------------------|---------------|------|
| Asphalt Concrete Base Course | Type B 25.0__ | 4.4% |
| Asphalt Concrete Intermediate Course | Type I 19.0__ | 4.8% |
| Asphalt Concrete Surface Course | Type S 4.75A | 6.8% |
| Asphalt Concrete Surface Course | Type SA-1 | 6.8% |
| Asphalt Concrete Surface Course | Type SF 9.5A | 6.7% |
| Asphalt Concrete Surface Course | Type S 9.5__ | 6.0% |
| Asphalt Concrete Surface Course | Type S 12.5__ | 5.6% |

The actual asphalt binder content will be established during construction by the Engineer within the limits established in the *2012 Standard Specifications*.

ASPHALT PLANT MIXTURES:

(7-1-95)

609

SP6 R20

Place asphalt concrete base course material in trench sections with asphalt pavement spreaders made for the purpose or with other equipment approved by the Engineer.

PRICE ADJUSTMENT - ASPHALT BINDER FOR PLANT MIX:

(11-21-00)

620

SP6 R25

Price adjustments for asphalt binder for plant mix will be made in accordance with Section 620 of the *2012 Standard Specifications*.

The base price index for asphalt binder for plant mix is \$ **373.50** per ton.

This base price index represents an average of F.O.B. selling prices of asphalt binder at supplier's terminals on **April 1, 2017**.

RIPRAP ENERGY DISSIPATOR BASIN:

(10-14-09) (Rev. 2-7-14)

Description

This work consists of the construction and maintenance of an armored outlet structure located at culvert outlets or ditch termini.

Materials

Refer to Division 10 of the *Standard Specifications*.

| Item | Section |
|---------------------------------|----------------|
| Class II Riprap | 1042 |
| Geotextile for Drainage, Type 2 | 1056 |

Construction Methods

Energy dissipators shall be constructed in accordance with the detail shown in the plans or as directed. From the outlet, invert of a culvert or bottom of a ditch excavation will drop to a specified depth. Excavation will continue to widen through the dissipator. Riprap shall be placed along the banks and bottom of the dissipator and along the apron.

Excavate ditch in accordance with Section 240 of the *Standard Specifications*.

The quantity of energy dissipator material may be affected by site conditions during construction of the project. The quantity of materials may be increased, decreased, or eliminated at the direction of the Engineer. Such variations in quantity will not be considered as alterations in the details of construction or a change in the character of the work.

Measurement and Payment

Energy Dissipator Basin will be measured and paid for in units of each. Such price and payment will be full compensation for all work covered by this section, including, but not limited to, furnishing and placing stone, filter fabric, materials, labor, tools, equipment, and incidentals necessary to complete the work.

Payment will be made under:

| Pay Item | Pay Unit |
|-------------------------|-----------------|
| Energy Dissipator Basin | Each |

SLUICE GATE:

(7-1-95) (Rev. 3-17-09)

838

SP8 R20

Description

This work consists of the construction of a sluice gate on an endwall in accordance with the details in the plans, the applicable requirements of Section 838 of the *2012 Standard Specifications*, in accordance with the manufacturer's recommendations and as directed by the Engineer.

Materials

Sluice gates shall meet the manufacturer's recommendations for the corresponding pipe size. Due to variations in individual manufacturer's products, a slight variation from the size specified may be allowed. Submit the proposed catalog cut to the Engineer for approval prior to use.

Construction Methods

Provide a gate that forms a watertight seal when closed.

Measurement and Payment

_____ " *Sluice Gate* will be measured and paid as each for the actual number of sluice gates incorporated into the completed and accepted work. Such prices and payment will be full compensation for all materials, labor, tools, equipment and incidentals necessary to complete the work.

The endwall will be measured and paid in accordance with Article 838-4 of the *2012 Standard Specifications*.

Payment will be made under:

Pay Item

_____ " Sluice Gate

Pay Unit

Each

GUARDRAIL ANCHOR UNITS, TYPE M-350:

(4-20-04) (Rev. 7-21-15)

862

SP08 R060

Description

Furnish and install guardrail anchor units in accordance with the details in the plans, the applicable requirements of Section 862 of the *2012 Standard Specifications*, and at locations shown in the plans.

Materials

Furnish guardrail anchor units listed on the NCDOT [Approved Products List](https://apps.dot.state.nc.us/vendor/approvedproducts/) at <https://apps.dot.state.nc.us/vendor/approvedproducts/> or approved equal.

Prior to installation the Contractor shall submit to the Engineer:

- (A) FHWA acceptance letter for each guardrail anchor unit certifying it meets the requirements of NCHRP Report 350, Test Level 3, in accordance with Article 106-2 of the *2012 Standard Specifications*.
- (B) Certified working drawings and assembling instructions from the manufacturer for each guardrail anchor unit in accordance with Article 105-2 of the *2012 Standard Specifications*.

No modifications shall be made to the guardrail anchor unit without the express written permission from the manufacturer. Perform installation in accordance with the details in the plans, and details and assembling instructions furnished by the manufacturer.

Construction Methods

Guardrail end delineation shall be required on all approach and trailing end sections for both temporary and permanent installations. Guardrail end delineation consists of yellow reflective sheeting applied to the entire end section of the guardrail in accordance with Article 1088-3 of the *2012 Standard Specifications* and is incidental to the cost of the guardrail anchor unit.

Measurement and Payment

Measurement and payment will be made in accordance with Article 862-6 of the *2012 Standard Specifications*.

Payment will be made under:

Pay Item

Guardrail Anchor Units, Type M-350

Pay Unit

Each

GUARDRAIL ANCHOR UNITS, TYPE 350 (TL-3):

(4-20-04) (Rev. 7-21-15)

862

SP08 R065

Description

Furnish and install guardrail anchor units in accordance with the details in the plans, the applicable requirements of Section 862 of the *2012 Standard Specifications*, and at locations shown in the plans.

Materials

Furnish guardrail anchor units listed on the NCDOT Approved Products List at <https://apps.dot.state.nc.us/vendor/approvedproducts/> or approved equal.

Prior to installation the Contractor shall submit to the Engineer:

- (A) FHWA acceptance letter for each guardrail anchor unit certifying it meets the requirements of NCHRP Report 350, Test Level 3, in accordance with Article 106-2 of the *2012 Standard Specifications*.
- (B) Certified working drawings and assembling instructions from the manufacturer for each guardrail anchor unit in accordance with Article 105-2 of the *2012 Standard Specifications*.

No modifications shall be made to the guardrail anchor unit without the express written permission from the manufacturer. Perform installation in accordance with the details in the plans, and details and assembling instructions furnished by the manufacturer.

Construction Methods

Guardrail end delineation is required on all approach and trailing end sections for both temporary and permanent installations. Guardrail end delineation consists of yellow reflective sheeting applied to the entire end section of the guardrail in accordance with Article 1088-3 of the *2012 Standard Specifications* and is incidental to the cost of the guardrail anchor unit.

Measurement and Payment

Measurement and payment will be made in accordance with Article 862-6 of the *2012 Standard Specifications*.

Payment will be made under:

| Pay Item | Pay Unit |
|----------------------------------|-----------------|
| Guardrail Anchor Units, Type 350 | Each |

IMPACT ATTENUATOR UNITS, TYPE 350:

(4-20-04) (Rev. 7-21-15)

SP08 R075

Description

Furnish and install impact attenuator units and any components necessary to connect the impact attenuator units in accordance with the manufacturer's requirement, the details in the plans and at locations shown in the plans.

Materials

Furnish impact attenuator units listed on the Approved Products List at <https://apps.dot.state.nc.us/vendor/approvedproducts/> or approved equal. Prior to installation the Contractor shall submit to the Engineer:

- (A) FHWA acceptance letter for each impact attenuator unit certifying it meets the requirements of NCHRP Report 350, Test Level 3, in accordance with Article 106-2 of the *2012 Standard Specifications*.
- (B) Certified working drawings and assembling instructions from the manufacturer for each impact attenuator unit in accordance with Article 105-2 of the *2012 Standard Specifications*.

No modifications shall be made to the impact attenuator unit without the express written permission from the manufacturer. Perform installation in accordance with the details in the plans and details and assembling instructions furnished by the manufacturer.

Construction Methods

If the median width is 40 feet or less, the Contractor shall supply NON-GATING Impact Attenuator Units.

If the median width is greater than 40 feet, the Contractor may use GATING or NON-GATING Impact Attenuator Units.

Measurement and Payment

Impact Attenuator Unit, Type 350 will be measured and paid at the contract unit price per each. Such prices and payment will be full compensation for all work covered by this provision including, but not limited to, furnishing, installing and all incidentals necessary to complete the work.

Payment will be made under:

| Pay Item | Pay Unit |
|-----------------------------------|-----------------|
| Impact Attenuator Units, Type 350 | Each |

MEDIAN HAZARD PROTECTION:

Description

Construct Median Hazard Protection at locations indicated in the plans, in accordance with the detail in the plans, and as directed by the Engineer.

Measurement and Payment

Median Hazard Protection will be measured and paid for per linear feet that are completed and accepted. Such price and payment will be full compensation for all labor, materials (including, but not limited to, concrete barrier, earth material, #57 stone, concrete cover, galvanized bar and grout) and incidentals necessary construct the Median Hazard Protection.

Payment will be made under:

| Pay Item | Pay Unit |
|--------------------------|-----------------|
| Median Hazard Protection | Linear Foot |

PREFORMED SCOUR HOLE WITH LEVEL SPREADER APRON:

(10-15-02) (Rev. 10-20-09)

410

SP8 R105

Description

Construct and maintain preformed scour holes with spreader aprons at the locations shown on the plans and in accordance with the details in the plans. Work includes excavation, shaping and maintaining the hole and apron, furnishing and placing filter fabric, rip rap (class as specified in the plans) and permanent soil reinforcement matting.

Materials

| Item | Section |
|---------------|----------------|
| Plain Rip Rap | 1042 |
| Filter Fabric | 1056 |

The permanent soil reinforcement matting shall be permanent erosion control reinforcement mat and shall be constructed of synthetic or a combination of coconut and synthetic fibers evenly distributed throughout the mat between a bottom UV stabilized netting and a heavy duty UV stabilized top net. The matting shall be stitched together with UV stabilized polypropylene thread to form a permanent three dimensional structure. The mat shall have the following minimum physical properties:

| Property | Test Method | Value Unit |
|--|------------------------|-------------------------|
| Light Penetration | ASTM D6567 | 9 % |
| Thickness | ASTM D6525 | 0.40 in |
| Mass Per Unit Area | ASTM D6566 | 0.55 lb/sy |
| Tensile Strength | ASTM D6818 | 385 lb/ft |
| Elongation (Maximum) | ASTM D6818 | 49 % |
| Resiliency | ASTM D1777 | >70 % |
| UV Stability * | ASTM 4355 | ≥80 % |
| Porosity (Permanent Net) | ECTC Guidelines | ≥85 % |
| Maximum Permissible Shear Stress (Vegetated) | Performance Bench Test | ≥8.0 lb/ft ² |
| Maximum Allowable Velocity (Vegetated) | Performance Bench Test | ≥16.0 ft/s |

*ASTM D1682 Tensile Strength and % strength retention of material after 1,000 hours of exposure.

Submit a certification (Type 1, 2, or 3) from the manufacturer showing:

- (A) The chemical and physical properties of the mat used, and
- (B) Conformance of the mat with this specification.

Construction Methods

All areas to be protected with the mat shall be brought to final grade and seeded in accordance with Section 1660 of the *2012 Standard Specifications*. The surface of the soil shall be smooth, firm, stable and free of rocks, clods, roots or other obstructions that would prevent the mat from lying in direct contact with the soil surface. Areas where the mat is to be placed will not need to be mulched.

Measurement and Payment

Preformed Scour Holes with Level Spreader Aprons will be measured and paid as the actual number incorporated into the completed and accepted work. Such price and payment will be full compensation for all work covered by this provision.

Payment will be made under:

| Pay Item | Pay Unit |
|---|-----------------|
| Preformed Scour Hole with Level Spreader Aprons | Each |

DETECTABLE WARNINGS FOR PROPOSED CURB RAMPS:

(6-15-10) (Rev. 8-16-11)

848

SP8 R126

Description

Construct detectable warnings consisting of integrated raised truncated domes on proposed concrete curb ramps in accordance with the *2012 Standard Specifications*, plan details, the requirements of the *28 CFR Part 36 ADA Standards for Accessible Design* and this provision.

Materials

Detectable warning for proposed curb ramps shall consist of integrated raised truncated domes. The description, size and spacing shall conform to Section 848 of the *2012 Standard Specifications*.

Use material for detectable warning systems as shown herein. Material and coating specifications must be stated in the Manufacturers Type 3 Certification and all Detectable Warning systems must be on the NCDOT Approved Products List.

Install detectable warnings created from one of the following materials: precast concrete blocks or bricks, clay paving brick, gray or ductile iron castings, mild steel, stainless steel, and engineered plastics, rubber or composite tile. Only one material type for detectable warning will be permitted per project, unless otherwise approved by the Engineer.

- (A) Detectable Warnings shall consist of a base with integrated raised truncated domes, and when constructed of precast concrete they shall conform to the material requirements of Article 848-2 of the *2012 Standard Specifications*.
- (B) Detectable Warnings shall consist of a base with integrated raised truncated domes, and may be comprised of other materials including, but not limited, to clay paving brick, gray iron or ductile iron castings, mild steel, stainless steel, and engineered plastics, rubber or composite tile, which are cast into the concrete of the curb ramps. The material shall have an integral color throughout the thickness of the material. The detectable warning shall include fasteners or anchors for attachment in the concrete and shall be furnished as a system from the manufacturer.

Prior to installation, the Contractor shall submit to the Engineer assembling instructions from the manufacturer for each type of system used in accordance with Article 105-2 of the *2012 Standard Specifications*. The system shall be furnished as a kit containing all consumable materials and consumable tools, required for the application. They shall be capable of being affixed to or anchored in the concrete curb ramp, including green concrete (concrete that has set but not appreciably hardened). The system shall be solvent free and contain no volatile organic compounds (VOC). The static coefficient of friction shall be 0.8 or greater when measured on top of the truncated domes and when measured between the domes in accordance with ASTM C1028 (dry and wet). The system shall be resistant to deterioration due to exposure to sunlight, water, salt or adverse weather conditions and impervious to degradation by motor fuels, lubricants and antifreeze.

- (C) When steel or gray iron or ductile iron casting products are provided, only products that meet the requirements of Subarticle 106-1(B) of the *2012 Standard Specifications* may be used. Submit to the Engineer a Type 6 Certification, catalog cuts and installation procedures at least 30 days prior to installation for all.

Construction Methods

- (A) Prior to placing detectable warnings in proposed concrete curb ramps, adjust the existing subgrade to the proper grade and in accordance with Article 848-3 of the *2012 Standard Specifications*.
- (B) Install all detectable warning in proposed concrete curb ramps in accordance with the manufacturer's recommendations.

Measurement and Payment

Detectable Warnings installed for construction of proposed curb ramps will not be paid for separately. Such payment will be included in the price bid for *Concrete Curb Ramps*.

FOUNDATIONS AND ANCHOR ROD ASSEMBLIES FOR METAL POLES:

(1-17-12) (Rev. 5-19-15)

9, 14, 17

SP9 R05

Description

Foundations for metal poles include foundations for signals, cameras, overhead and dynamic message signs (DMS) and high mount and low level light standards supported by metal poles or upright trusses. Foundations consist of footings with pedestals and drilled piers with or without grade beams or wings. Anchor rod assemblies consist of anchor rods (also called anchor bolts) with nuts and washers on the exposed ends of rods and nuts and a plate or washers on the other ends of rods embedded in the foundation.

Construct concrete foundations with the required resistances and dimensions and install anchor rod assemblies in accordance with the contract and accepted submittals. Construct drilled piers consisting of cast-in-place reinforced concrete cylindrical sections in excavated holes. Provide temporary casings or polymer slurry as needed to stabilize drilled pier excavations. Use a prequalified Drilled Pier Contractor to construct drilled piers for metal poles. Define "excavation" and "hole" as a drilled pier excavation and "pier" as a drilled pier.

This provision does not apply to materials and anchor rod assemblies for standard foundations for low level light standards. See Section 1405 of the *2012 Standard Specifications* and Standard Drawing No. 1405.01 of the *2012 Roadway Standard Drawings* for materials and anchor rod assemblies for standard foundations. For construction of standard foundations for low level light standards, standard foundations are considered footings in this provision.

This provision does not apply to foundations for signal pedestals; see Section 1743 of the *2012 Standard Specifications* and Standard Drawing No. 1743.01 of the *2012 Roadway Standard Drawings*.

Materials

Refer to the *2012 Standard Specifications*.

| Item | Section |
|--------------------------|----------------|
| Conduit | 1091-3 |
| Grout, Type 2 | 1003 |
| Polymer Slurry | 411-2(B) |
| Portland Cement Concrete | 1000 |
| Reinforcing Steel | 1070 |
| Rollers and Chairs | 411-2(C) |
| Temporary Casings | 411-2(A) |

Provide Type 3 material certifications in accordance with Article 106-3 of the *2012 Standard Specifications* for conduit, rollers, chairs and anchor rod assemblies. Store steel materials on blocking at least 12" above the ground and protect it at all times from damage; and when placing in the work make sure it is free from dirt, dust, loose mill scale, loose rust, paint, oil or other foreign materials. Load, transport, unload and store foundation and anchor rod assembly materials so materials are kept clean and free of damage. Bent, damaged or defective materials will be rejected.

Use conduit type in accordance with the contract. Use Class A concrete for footings and pedestals, Class Drilled Pier concrete for drilled piers and Class AA concrete for grade beams and wings including portions of drilled piers above bottom of wings elevations. Corrugated temporary casings may be accepted at the discretion of the Engineer. A list of approved polymer slurry products is available from:

connect.ncdot.gov/resources/Geological/Pages/Products.aspx

Provide anchor rod assemblies in accordance with the contract consisting of the following:

- (A) Straight anchor rods,
- (B) Heavy hex top and leveling nuts and flat washers on exposed ends of rods, and
- (C) Nuts and either flat plates or washers on the other ends of anchor rods embedded in foundations.

Do not use lock washers. Use steel anchor rods, nuts and washers that meet ASTM F1554 for Grade 55 rods and Grade A nuts. Use steel plates and washers embedded in concrete with a thickness of at least 1/4". Galvanize anchor rods and exposed nuts and washers in accordance with Article 1076-4 of the *2012 Standard Specifications*. It is not necessary to galvanize nuts, plates and washers embedded in concrete.

Construction Methods

Install the required size and number of conduits in foundations in accordance with the plans and accepted submittals. Construct top of piers, footings, pedestals, grade beams and wings flat, level and within 1" of elevations shown in the plans or approved by the Engineer. Provide an Ordinary Surface finish in accordance with Subarticle 825-6(B) of the *2012 Standard Specifications* for portions of foundations exposed above finished grade. Do not remove anchor bolt templates or pedestal or grade beam forms or erect metal poles or upright trusses onto foundations until concrete attains a compressive strength of at least 3,000 psi.

(A) Drilled Piers

Before starting drilled pier construction, hold a predrill meeting to discuss the installation, monitoring and inspection of the drilled piers. Schedule this meeting after the Drilled Pier Contractor has mobilized to the site. The Resident or Division Traffic Engineer, Contractor and Drilled Pier Contractor Superintendent will attend this predrill meeting.

Do not excavate holes, install piles or allow equipment wheel loads or vibrations within 20 ft of completed piers until 16 hours after Drilled Pier concrete reaches initial set.

Check for correct drilled pier alignment and location before beginning drilling. Check plumbness of holes frequently during drilling.

Construct drilled piers with the minimum required diameters shown in the plans. Install piers with tip elevations no higher than shown in the plans or approved by the Engineer.

Excavate holes with equipment of the sizes required to construct drilled piers. Depending on the subsurface conditions encountered, drilling through rock and boulders may be required. Do not use blasting for drilled pier excavations.

Contain and dispose of drilling spoils and waste concrete as directed and in accordance with Section 802 of the *2012 Standard Specifications*. Drilling spoils consist of all materials and fluids removed from excavations.

If unstable, caving or sloughing materials are anticipated or encountered, stabilize holes with temporary casings and/or polymer slurry. Do not use telescoping temporary casings. If it becomes necessary to replace a temporary casing during drilling, backfill the excavation, insert a larger casing around the casing to be replaced or stabilize the excavation with polymer slurry before removing the temporary casing.

If temporary casings become stuck or the Contractor proposes leaving casings in place, temporary casings should be installed against undisturbed material. Unless otherwise

approved, do not leave temporary casings in place for mast arm poles and cantilever signs. The Engineer will determine if casings may remain in place. If the Contractor proposes leaving temporary casings in place, do not begin drilling until a casing installation method is approved.

Use polymer slurry and additives to stabilize holes in accordance with the slurry manufacturer's recommendations. Provide mixing water and equipment suitable for polymer slurry. Maintain polymer slurry at all times so slurry meets Table 411-3 of the *2012 Standard Specifications* except for sand content.

Define a "sample set" as slurry samples collected from mid-height and within 2 ft of the bottom of holes. Take sample sets from excavations to test polymer slurry immediately after filling holes with slurry, at least every 4 hours thereafter and immediately before placing concrete. Do not place Drilled Pier concrete until both slurry samples from an excavation meet the required polymer slurry properties. If any slurry test results do not meet the requirements, the Engineer may suspend drilling until both samples from a sample set meet the required slurry properties.

Remove soft and loose material from bottom of holes using augers to the satisfaction of the Engineer. Assemble rebar cages and place cages and Drilled Pier concrete in accordance with Subarticle 411-4(E) of the *2012 Standard Specifications* except for the following:

- (1) Inspections for tip resistance and bottom cleanliness are not required,
- (2) Temporary casings may remain in place if approved, and
- (3) Concrete placement may be paused near the top of pier elevations for anchor rod assembly installation and conduit placement or
- (4) If applicable, concrete placement may be stopped at bottom of grade beam or wings elevations for grade beam or wing construction.

If wet placement of concrete is anticipated or encountered, do not place Drilled Pier concrete until a concrete placement procedure is approved. If applicable, temporary casings and fluids may be removed when concrete placement is paused or stopped in accordance with the exceptions above provided holes are stable. Remove contaminated concrete from exposed Drilled Pier concrete after removing casings and fluids. If holes are unstable, do not remove temporary casings until a procedure for placing anchor rod assemblies and conduit or constructing grade beams or wings is approved.

Use collars to extend drilled piers above finished grade. Remove collars after Drilled Pier concrete sets and round top edges of piers.

If drilled piers are questionable, pile integrity testing (PIT) and further investigation may be required in accordance with Article 411-5 of the *2012 Standard Specifications*. A drilled pier will be considered defective in accordance with Subarticle 411-5(D) of the *2012 Standard Specifications* and drilled pier acceptance is based in part on the criteria in Article 411-6 of the *2012 Standard Specifications* except for the top of pier tolerances in Subarticle 411-6(C) of the *2012 Standard Specifications*.

If a drilled pier is under further investigation, do not grout core holes, backfill around the pier or perform any work on the drilled pier until the Engineer accepts the pier. If the drilled pier is accepted, dewater and grout core holes and backfill around the pier with approved material to finished grade. If the Engineer determines a pier is unacceptable, remediation is required in accordance with Article 411-6 of the *2012 Standard Specifications*. No extension of completion date or time will be allowed for remediation of unacceptable drilled piers or post repair testing.

Permanently embed a plate in or mark top of piers with the pier diameter and depth, size and number of vertical reinforcing bars and the minimum compressive strength of the concrete mix at 28 days.

(B) Footings, Pedestals, Grade Beams and Wings

Excavate as necessary for footings, grade beams and wings in accordance with the plans, accepted submittals and Section 410 of the *2012 Standard Specifications*. If unstable, caving or sloughing materials are anticipated or encountered, shore foundation excavations as needed with an approved method. Notify the Engineer when foundation excavation is complete. Do not place concrete or reinforcing steel until excavation dimensions and foundation material are approved.

Construct cast-in-place reinforced concrete footings, pedestals, grade beams and wings with the dimensions shown in the plans and in accordance with Section 825 of the *2012 Standard Specifications*. Use forms to construct portions of pedestals and grade beams protruding above finished grade. Provide a chamfer with a 3/4" horizontal width for pedestal and grade beam edges exposed above finished grade. Backfill and fill in accordance with Article 410-8 of the *2012 Standard Specifications*. Proper compaction around footings and wings is critical for foundations to resist uplift and torsion forces. Place concrete against undisturbed soil and do not use forms for standard foundations for low level light standards.

(C) Anchor Rod Assemblies

Size anchor rods for design and the required projection above top of foundations. Determine required anchor rod projections from nut, washer and base plate thicknesses, the protrusion of 3 to 5 anchor rod threads above top nuts after tightening and the distance of one nut thickness between top of foundations and bottom of leveling nuts.

Protect anchor rod threads from damage during storage and installation of anchor rod assemblies. Before placing anchor rods in foundations, turn nuts onto and off rods past leveling nut locations. Turn nuts with the effort of one workman using an ordinary wrench without a cheater bar. Report any thread damage to the Engineer that requires extra effort to turn nuts.

Arrange anchor rods symmetrically about center of base plate locations as shown in the plans. Set anchor rod elevations based on required projections above top of foundations. Securely brace and hold rods in the correct position, orientation and alignment with a steel template. Do not weld to reinforcing steel, temporary casings or anchor rods.

Install top and leveling (bottom) nuts, washers and the base plate for each anchor rod assembly in accordance with the following procedure:

- (1) Turn leveling nuts onto anchor rods to a distance of one nut thickness between the top of foundation and bottom of leveling nuts. Place washers over anchor rods on top of leveling nuts.
- (2) Determine if nuts are level using a flat rigid template on top of washers. If necessary, lower leveling nuts to level the template in all directions or if applicable, lower nuts to tilt the template so the metal pole or upright truss will lean as shown in the plans. If leveling nuts and washers are not in full contact with the template, replace washers with galvanized beveled washers.
- (3) Verify the distance between the foundation and leveling nuts is no more than one nut thickness.
- (4) Place base plate with metal pole or upright truss over anchor rods on top of washers. High mount luminaires may be attached before erecting metal poles but do not attach cables, mast arms or trusses to metal poles or upright trusses at this time.
- (5) Place washers over anchor rods on top of base plate. Lubricate top nut bearing surfaces and exposed anchor rod threads above washers with beeswax, paraffin or other approved lubricant.
- (6) Turn top nuts onto anchor rods. If nuts are not in full contact with washers or washers are not in full contact with the base plate, replace washers with galvanized beveled washers.
- (7) Tighten top nuts to snug-tight with the full effort of one workman using a 12" wrench. Do not tighten any nut all at once. Turn top nuts in increments. Follow a star pattern cycling through each nut at least twice.
- (8) Repeat (7) for leveling nuts.
- (9) Replace washers above and below the base plate with galvanized beveled washers if the slope of any base plate face exceeds 1:20 (5%), any washer is not in firm contact with the base plate or any nut is not in firm contact with a washer. If any washers are replaced, repeat (7) and (8).
- (10) With top and leveling nuts snug-tight, mark each top nut on a corner at the intersection of 2 flats and a corresponding reference mark on the base plate. Mark top nuts and base plate with ink or paint that is not water-soluble. Use the turn-of-nut method for pretensioning. Do not pretension any nut all at once. Turn top nuts in increments for a total turn that meets the following nut rotation requirements:

| NUT ROTATION REQUIREMENTS (Turn-of-Nut Pretensioning Method) | |
|---|--------------------|
| Anchor Rod Diameter, inch | Requirement |
| $\leq 1 \frac{1}{2}$ | 1/3 turn (2 flats) |
| $> 1 \frac{1}{2}$ | 1/6 turn (1 flat) |

Follow a star pattern cycling through each top nut at least twice.

- (11) Ensure nuts, washers and base plate are in firm contact with each other for each anchor rod. Cables, mast arms and trusses may now be attached to metal poles and upright trusses.
- (12) Between 4 and 14 days after pretensioning top nuts, use a torque wrench calibrated within the last 12 months to check nuts in the presence of the Engineer. Completely

erect mast arm poles and cantilever signs and attach any hardware before checking top nuts for these structures. Check that top nuts meet the following torque requirements:

| TORQUE REQUIREMENTS | |
|----------------------------------|---------------------------|
| Anchor Rod Diameter, inch | Requirement, ft-lb |
| 7/8 | 180 |
| 1 | 270 |
| 1 1/8 | 380 |
| 1 1/4 | 420 |
| ≥ 1 1/2 | 600 |

If necessary, retighten top nuts in the presence of the Engineer with a calibrated torque wrench to within ± 10 ft-lb of the required torque. Do not overtighten top nuts.

- (13) Do not grout under base plate.

Measurement and Payment

Foundations and anchor rod assemblies for metal poles and upright trusses will be measured and paid for elsewhere in the contract.

No payment will be made for temporary casings that remain in drilled pier excavations. No payment will be made for PIT. No payment will be made for further investigation of defective piers. Further investigation of piers that are not defective will be paid as extra work in accordance with Article 104-7 of the *2012 Standard Specifications*. No payment will be made for remediation of unacceptable drilled piers or post repair testing.

MATERIALS:

(2-21-12) (Rev. 11-22-16) 1000, 1002, 1005, 1016, 1018, 1024, 1050, 1074, 1078, 1080, 1081, 1086, 1084, 1087, 1092 SP10 R01

Revise the *2012 Standard Specifications* as follows:

Page 10-1, Article 1000-1, DESCRIPTION, lines 9-10, replace the last sentence of the first paragraph with the following:

Type IL, IP, IS or IT blended cement may be used instead of Portland cement.

Page 10-1, Article 1000-1, DESCRIPTION, line 14, add the following:

If any change is made to the mix design, submit a new mix design (with the exception of an approved pozzolan source change).

If any major change is made to the mix design, also submit new test results showing the mix design conforms to the criteria. Define a major change to the mix design as:

- (1) A source change in coarse aggregate, fine aggregate or cement.
- (2) A pozzolan class or type change (e.g. Class F fly ash to Class C fly ash).
- (3) A quantitative change in coarse aggregate (applies to an increase or decrease greater than

5%), fine aggregate (applies to an increase or decrease greater than 5%), water (applies to an increase only), cement (applies to a decrease only), or pozzolan (applies to an increase or decrease greater than 5%).

Use materials which do not produce a mottled appearance through rusting or other staining of the finished concrete surface.

Page 10-1, Article 1000-2, MATERIALS, line 16; Page 10-8, Subarticle 1000-7(A), Materials, line 8; and Page 10-18, Article 1002-2, MATERIALS, line 9, add the following to the table of item references:

| Item | Section |
|------------------------|----------------|
| Type IL Blended Cement | 1024-1 |

Page 10-1, Subarticle 1000-3(A), Composition and Design, lines 25-27, replace the second paragraph with the following:

Fly ash may be substituted for cement in the mix design up to 30% at a rate of 1.0 lb of fly ash to each pound of cement replaced.

Page 10-2, Subarticle 1000-3(A), Composition and Design, lines 12-21, delete the third paragraph through the sixth paragraph beginning with “If any change is made to the mix design, submit...” through “...(applies to a decrease only).”

Page 10-5, Table 1000-1, REQUIREMENTS FOR CONCRETE, replace with the following:

| TABLE 1000-1 REQUIREMENTS FOR CONCRETE | | | | | | | | | | | |
|---|--|----------------------------|-------------------|----------------------------|-------------------|---------------------------------------|--------------------|----------------|-----------|--------------|-----------|
| Class of Concrete | Min. Comp. Strength at 28 days | Maximum Water-Cement Ratio | | | | Consistency Max. Slump | | Cement Content | | | |
| | | Air-Entrained Concrete | | Non Air-Entrained Concrete | | Vibrated | Non-Vibrated | Vibrated | | Non-Vibrated | |
| | | Rounded Aggregate | Angular Aggregate | Rounded Aggregate | Angular Aggregate | | | Min. | Max. | Min. | Max. |
| Units | psi | | | | | inch | inch | lb/cy | lb/cy | lb/cy | lb/cy |
| AA | 4,500 | 0.381 | 0.426 | - | - | 3.5 | - | 639 | 715 | - | - |
| AA Slip Form | 4,500 | 0.381 | 0.426 | - | - | 1.5 | - | 639 | 715 | - | - |
| Drilled Pier | 4,500 | - | - | 0.450 | 0.450 | - | 5-7 dry 7-9 wet | - | - | 640 | 800 |
| A | 3,000 | 0.488 | 0.532 | 0.550 | 0.594 | 3.5 | 4 | 564 | - | 602 | - |
| B | 2,500 | 0.488 | 0.567 | 0.559 | 0.630 | 1.5 machine-placed 2.5 hand-placed | 4 | 508 | - | 545 | - |
| Sand Light-weight | 4,500 | - | 0.420 | - | - | 4 | - | 715 | - | - | - |
| Latex Modified | 3,000 7 day | 0.400 | 0.400 | - | - | 6 | - | 658 | - | - | - |
| Flowable Fill excavatable | 150 max. at 56 days | as needed | as needed | as needed | as needed | - | Flow-able | - | - | 40 | 100 |
| Flowable Fill non-excavatable | 125 | as needed | as needed | as needed | as needed | - | Flow-able | - | - | 100 | as needed |
| Pavement | 4,500 design, field 650 flexural, design only | 0.559 | 0.559 | - | - | 1.5 slip form 3.0 hand place | - | 526 | - | - | - |
| Precast | See Table 1077-1 | as needed | as needed | - | - | 6 | as needed | as needed | as needed | as needed | as needed |
| Prestress | per contract | See Table 1078-1 | See Table 1078-1 | - | - | 8 | - | 564 | as needed | - | - |

Page 10-6, Subarticle 1000-4(I), Use of Fly Ash, lines 36-2, replace the first paragraph with the following:

Fly ash may be substituted for cement in the mix design up to 30% at a rate of 1.0 lb of fly ash to each pound of cement replaced. Use Table 1000-1 to determine the maximum allowable water-cementitious material (cement + fly ash) ratio for the classes of concrete listed.

Page 10-7, Table 1000-3, MAXIMUM WATER-CEMENTITIOUS MATERIAL RATIO, delete the table.

Page 10-7, Article 1000-5, HIGH EARLY STRENGTH PORTLAND CEMENT CONCRETE, lines 30-31, delete the second sentence of the third paragraph.

Page 10-19, Article 1002-3, SHOTCRETE FOR TEMPORARY SUPPORT OF EXCAVATIONS, line 30, add the following at the end of Section 1002:

(H) Handling and Storing Test Panels

Notify the Area Materials Engineer when preconstruction or production test panels are made within 24 hours of shooting the panels. Field cure and protect test panels from damage in accordance with ASTM C1140 until the Department transports panels to the Materials and Tests Regional Laboratory for coring.

Page 10-23, Table 1005-1, AGGREGATE GRADATION-COARSE AGGREGATE, replace with the following:

| TABLE 1005-1 AGGREGATE GRADATION - COARSE AGGREGATE | | | | | | | | | | | | | |
|--|-----|--------|--------|--------|--------|--------|--------|-------|-------|------|-------|-------------------|--|
| Percentage of Total by Weight Passing | | | | | | | | | | | | | |
| Std. Size # | 2" | 1 1/2" | 1" | 3/4" | 1/2" | 3/8" | #4 | #8 | #10 | #16 | #40 | #200 | Remarks |
| 4 | 100 | 90-100 | 20-55 | 0-15 | - | 0-5 | - | - | - | - | - | A | Asphalt Plant Mix |
| 467M | 100 | 95-100 | - | 35-70 | - | 0-30 | 0-5 | - | - | - | - | A | Asphalt Plant Mix |
| 5 | - | 100 | 90-100 | 20-55 | 0-10 | 0-5 | - | - | - | - | - | A | AST, Sediment Control Stone |
| 57 | - | 100 | 95-100 | - | 25-60 | - | 0-10 | 0-5 | - | - | - | A | AST, Structural Concrete, Shoulder Drain Stone, Sediment Control Stone |
| 57M | - | 100 | 95-100 | - | 25-45 | - | 0-10 | 0-5 | - | - | - | A | AST, Concrete Pavement |
| 6M | - | - | 100 | 90-100 | 20-55 | 0-20 | 0-8 | - | - | - | - | A | AST |
| 67 | - | - | 100 | 90-100 | - | 20-55 | 0-10 | 0-5 | - | - | - | A | Asphalt Plant Mix, AST, Structural Concrete |
| 78M | - | - | - | 100 | 98-100 | 75-100 | 20-45 | 0-15 | - | - | - | A | Asphalt Plant Mix, AST, Structural Concrete, Weep Hole Drains |
| 14M | - | - | - | - | 100 | 98-100 | 35-70 | 5-20 | - | 0-8 | - | A | Asphalt Plant Mix, AST, Structural Concrete, Weep Hole Drains |
| 9M | - | - | - | - | 100 | 98-100 | 85-100 | 10-40 | - | 0-10 | - | A | AST |
| ABC | - | 100 | 75-97 | - | 55-80 | - | 35-55 | - | 25-45 | - | 14-30 | 4-12 ^B | Aggregate Base Course, Aggregate Stabilization |
| ABC(M) | - | 100 | 75-100 | - | 45-79 | - | 20-40 | - | 0-25 | - | - | 0-12 ^B | Maintenance Stabilization |
| Light-weight ^C | - | - | - | - | 100 | 80-100 | 5-40 | 0-20 | - | 0-10 | - | 0-2.5 | AST |

- A. See Subarticle 1005-4(A).
- B. See Subarticle 1005-4(B).
- C. For Lightweight Aggregate used in Structural Concrete, see Subarticle 1014-2(E)(6).

Page 10-39, Article 1016-3, CLASSIFICATIONS , lines 27-32, replace with the following:

Select material is clean, unweathered durable, blasted rock material obtained from an approved source. While no specific gradation is required, the below criteria will be used to evaluate the materials for visual acceptance by the Engineer:

- (A) At least 50% of the rock has a diameter of from 1.5 ft to 3 ft,
- (B) 30% of the rock ranges in size from 2” to 1.5 ft in diameter, and
- (C) Not more than 20% of the rock is less than 2” in diameter. No rippable rock will be permitted.

Page 10-40, Tables 1018-1 and 1018-2, PIEDMONT, WESTERN AND COASTAL AREA CRITERIA FOR ACCEPTANCE OF BORROW MATERIAL, under second column in both tables, replace second row with the following:

Acceptable, but not to be used in the top 3 ft of embankment or backfill

Page 10-46, Article 1024-1, PORTLAND CEMENT, line 33, add the following as the ninth paragraph:

Use Type IL blended cement that meets AASHTO M 240, except that the limestone content is limited to between 5 and 12% by weight and the constituents shall be interground. Class F fly ash can replace a portion of Type IL blended cement and shall be replaced as outlined in Subarticle 1000-4(I) for Portland cement. For mixes that contain cement with alkali content between 0.6% and 1.0% and for mixes that contain a reactive aggregate documented by the Department, use a pozzolan in the amount shown in Table 1024-1.

Page 10-46, Table 1024-1, POZZOLANS FOR USE IN PORTLAND CEMENT CONCRETE, replace with the following:

| TABLE 1024-1 POZZOLANS FOR USE IN PORTLAND CEMENT CONCRETE | |
|---|--|
| Pozzolan | Rate |
| Class F Fly Ash | 20% - 30% by weight of required cement content with 1.0 lb Class F fly ash per lb of cement replaced |
| Ground Granulated Blast Furnace Slag | 35%-50% by weight of required cement content with 1.0 lb slag per lb of cement replaced |
| Microsilica | 4%-8% by weight of required cement content with 1.0 lb microsilica per lb of cement replaced |

Page 10-47, Subarticle 1024-3(B), Approved Sources, lines 16-18, replace the second sentence of the second paragraph with the following:

Tests shall be performed by AASHTO’s designated National Transportation Product Evaluation Program (NTPEP) laboratory for concrete admixture testing.

Page 10-65, Article 1050-1, GENERAL, line 41, replace the first sentence with the following:

All fencing material and accessories shall meet Section 106.

Page 10-115, Subarticle 1074-7(B), Gray Iron Castings, lines 10-11, replace the first two sentences with the following:

Supply gray iron castings meeting all facets of AASHTO M 306 excluding proof load. Proof load testing will only be required for new casting designs during the design process, and conformance to M306 loading (40,000 lb.) will be required only when noted on the design documents.

Page 10-126, Table 1078-1, REQUIREMENTS FOR CONCRETE, replace with the following:

| TABLE 1078-1 REQUIREMENTS FOR CONCRETE | | |
|---|---|--|
| Property | 28 Day Design Compressive Strength 6,000 psi or less | 28 Day Design Compressive Strength greater than 6,000 psi |
| Maximum Water/Cementitious Material Ratio | 0.45 | 0.40 |
| Maximum Slump without HRWR | 3.5" | 3.5" |
| Maximum Slump with HRWR | 8" | 8" |
| Air Content (upon discharge into forms) | 5 + 2% | 5 + 2% |

Page 10-151, Article 1080-4, INSPECTION AND SAMPLING, lines 18-22, replace (B), (C) and (D) with the following:

- (B) At least 3 panels prepared as specified in 5.5.10 of AASHTO M 300, Bullet Hole Immersion Test.
- (C) At least 3 panels of 4"x6"x1/4" for the Elcometer Adhesion Pull Off Test, ASTM D4541.
- (D) A certified test report from an approved independent testing laboratory for the Salt Fog Resistance Test, Cyclic Weathering Resistance Test, and Bullet Hole Immersion Test as specified in AASHTO M 300.
- (E) A certified test report from an approved independent testing laboratory that the product has been tested for slip coefficient and meets AASHTO M253, Class B.

Page 10-161, Subarticle 1081-1(A), Classifications, lines 29-33, delete first 3 sentences of the description for Type 2 and replace with the following:

Type 2 - A low-modulus, general-purpose adhesive used in epoxy mortar repairs. It may be used to patch spalled, cracked or broken concrete where vibration, shock or expansion and contraction are expected.

Page 10-162, Subarticle 1081-1(A), Classifications, lines 4-7, delete the second and third sentences of the description for Type 3A. **Lines 16-22,** delete Types 6A, 6B and 6C.

Page 10-162, Subarticle 1081-1(B), Requirements, lines 26-30, replace the second paragraph with the following:

For epoxy resin systems used for embedding dowel bars, threaded rods, rebar, anchor bolts and other fixtures in hardened concrete, the manufacturer shall submit test results showing that the bonding system will obtain 125% of the specified required yield strength of the fixture. Furnish certification that, for the particular bolt grade, diameter and embedment depth required, the anchor system will not fail by adhesive failure and that there is no movement of the anchor bolt. For certification and anchorage, use 3,000 psi as the minimum Portland cement concrete compressive strength used in this test. Use adhesives that meet Section 1081.

List the properties of the adhesive on the container and include density, minimum and maximum temperature application, setting time, shelf life, pot life, shear strength and compressive strength.

Page 10-163, Table 1081-1, PROPERTIES OF MIXED EPOXY RESIN SYSTEMS, replace with the following:

| Property | Type 1 | Type 2 | Type 3 | Type 3A | Type 4A | Type 4B | Type 5 |
|--|--------------|---------|--------|--------------|---------|---------|--------|
| Viscosity-Poises at 77°F ± 2°F | Gel | 10-30 | 25-75 | Gel | 40-150 | 40-150 | 1-6 |
| Spindle No. | - | 3 | 4 | -- | 4 | 4 | 2 |
| Speed (RPM) | - | 20 | 20 | -- | 10 | 10 | 50 |
| Pot Life (Minutes) | 20-50 | 30-60 | 20-50 | 5-50 | 40-80 | 40-80 | 20-60 |
| Minimum Tensile Strength at 7 days (psi) | 1,500 | 2,000 | 4,000 | 4,000 | 1,500 | 1,500 | 4,000 |
| Tensile Elongation at 7 days (%) | 30 min. | 30 min. | 2-5 | 2-5 | 5-15 | 5-15 | 2-5 |
| Min. Compressive Strength of 2" mortar cubes at 24 hours | 3,000 (Neat) | 4,000- | 6,000- | 6,000 (Neat) | 3,000 | 3,000 | 6,000 |
| Min. Compressive Strength of 2" mortar cubes at 7 days | 5,000 (Neat) | - | - | - | - | 5,000 | - |
| Maximum Water Absorption (%) | 1.5 | 1.0 | 1.0 | 1.5 | 1.0 | 1.0 | 1.0 |
| Min. Bond Strength Slant Shear Test at 14 days (psi) | 1,500 | 1,500 | 2,000 | 2,000 | 1,500 | 1,500 | 1,500 |

Page 10-164, Subarticle 1081-1(E), Prequalification, lines 31-33, replace the second sentence of the first paragraph with the following:

Manufacturers choosing to supply material for Department jobs must submit an application through the Value Management Unit with the following information for each type and brand name:

Page 10-164, Subarticle 1081-1(E)(3), line 37, replace with the following:

(3) Type of the material in accordance with Articles 1081-1 and 1081-4,

Page 10-165, Subarticle 1081-1(E)(6), line 1, in the first sentence of the first paragraph replace “AASHTO M 237” with “the specifications”.

Page 10-165, Subarticle 1081-1(E), Prequalification, line 9-10, delete the second sentence of the last paragraph.

Page 10-165, Subarticle 1081-1(F), Acceptance, line 14, in the first sentence of the first paragraph replace “Type 1” with “Type 3”.

Page 10-169, Subarticle 1081-3(G), Anchor Bolt Adhesives, delete this subarticle.

Page 10-170, Article 1081-3, HOT BITUMEN, line 9, add the following at the end of Section 1081:

1081-4 EPOXY RESIN ADHESIVE FOR BONDING TRAFFIC MARKINGS

(A) General

This section covers epoxy resin adhesive for bonding traffic markers to pavement surfaces.

(B) Classification

The types of epoxies and their uses are as shown below:

Type I – Rapid Setting, High Viscosity, Epoxy Adhesive. This type of adhesive provides rapid adherence to traffic markers to the surface of pavement.

Type II – Standard Setting, High Viscosity, Epoxy Adhesive. This type of adhesive is recommended for adherence of traffic markers to pavement surfaces when rapid set is not required.

Type III – Rapid Setting, Low Viscosity, Water Resistant, Epoxy Adhesive. This type of rapid setting adhesive, due to its low viscosity, is appropriate only for use with embedded traffic markers.

Type IV – Standard Set Epoxy for Blade Deflecting-Type Plowable Markers.

(C) Requirements

Epoxies shall conform to the requirements set forth in AASHTO M 237.

(D) Prequalification

Refer to Subarticle 1081-1(E).

(E) Acceptance

Refer to Subarticle 1081-1(F).

Page 10-173, Article 1084-2, STEEL SHEET PILES, lines 37-38, replace first paragraph with the following:

Steel sheet piles detailed for permanent applications shall be hot rolled and meet ASTM A572 or ASTM A690 unless otherwise required by the plans. Steel sheet piles shall be coated as required by the plans. Galvanized sheet piles shall be coated in accordance with Section 1076.

Metallized sheet piles shall be metallized in accordance to the Project Special Provision “Thermal Sprayed Coatings (Metallization)” with an 8 mil, 99.9% aluminum alloy coating and a 0.5 mil seal coating. Any portion of the metallized sheet piling encased in concrete shall receive a barrier coat. The barrier coat shall be an approved waterborne coating with a low-

viscosity which readily absorbs into the pores of the aluminum thermal sprayed coating. The waterborne coating shall be applied at a spreading rate that results in a theoretical 1.5 mil dry film thickness. The manufacturer shall issue a letter of certification that the resin chemistry of the waterborne coating is compatible with the 99.9% aluminum thermal sprayed alloy and suitable for tidal water applications.

Page 10-174, Subarticle 1086-1(B)(1), Epoxy, lines 18-24, replace with the following:

The epoxy shall meet Article 1081-4.

The 2 types of epoxy adhesive which may be used are Type I, Rapid Setting, and Type II, Standard Setting. Use Type II when the pavement temperature is above 60°F or per the manufacturer's recommendations whichever is more stringent. Use Type I when the pavement temperature is between 50°F and 60°F or per the manufacturer's recommendations whichever is more stringent. Epoxy adhesive Type I, Cold Set, may be used to attach temporary pavement markers to the pavement surface when the pavement temperature is between 32°F and 50°F or per the manufacturer's recommendations whichever is more stringent.

Page 10-175, Subarticle 1086-2(E), Epoxy Adhesives, line 27, replace "Section 1081" with "Article 1081-4".

Page 10-177, Subarticle 1086-3(E), Epoxy Adhesives, line 22, replace "Section 1081" with "Article 1081-4".

Page 10-179, Subarticle 1087-4(A), Composition, lines 39-41, replace the third paragraph with the following:

All intermixed and drop-on glass beads shall not contain more than 75 ppm arsenic or 200 ppm lead.

Page 10-180, Subarticle 1087-4(B), Physical Characteristics, line 8, replace the second paragraph with the following:

All intermixed and drop-on glass beads shall comply with NCGS § 136-30.2 and 23 USC § 109(r).

Page 10-181, Subarticle 1087-7(A), Intermixed and Drop-on Glass Beads, line 24, add the following after the first paragraph:

Use X-ray Fluorescence for the normal sampling procedure for intermixed and drop-on beads, without crushing, to check for any levels of arsenic and lead. If any arsenic or lead is detected, the sample shall be crushed and repeat the test using X-ray Fluorescence. If the X-ray Fluorescence test shows more than a LOD of 5 ppm, test the beads using United States Environmental Protection Agency Method 6010B, 6010C or 3052 for no more than 75 ppm arsenic or 200 ppm lead.

HIGH STRENGTH CONCRETE FOR DRIVEWAYS:

(11-21-00) (Rev. 1-17-12)

848

SP10 R02

Use high early strength concrete for all driveways shown in the plans and as directed by the Engineer. Provide high early strength concrete that meets the requirements of Article 1000-5 of the *2012 Standard Specifications*.

Measurement and payment will be in accordance with Section 848 of the *2012 Standard Specifications*.

SELECT MATERIAL, CLASS III, TYPE 3:

(1-17-12)

1016, 1044

SP10 R05

Revise the *2012 Standard Specifications* as follows:

Page 10-39, Article 1016-3, CLASS III, add the following after line 14:

Type 3 Select Material

Type 3 select material is a natural or manufactured fine aggregate material meeting the following gradation requirements and as described in Sections 1005 and 1006:

| Percentage of Total by Weight Passing | | | | | | | |
|---------------------------------------|--------|--------|-------|-------|------|------|------|
| 3/8" | #4 | #8 | #16 | #30 | #50 | #100 | #200 |
| 100 | 95-100 | 65-100 | 35-95 | 15-75 | 5-35 | 0-25 | 0-8 |

Page 10-39, Article 1016-3, CLASS III, line 15, replace “either type” with “Type 1, Type 2 or Type 3”.

Page 10-62, Article 1044-1, line 36, delete the sentence and replace with the following:

Subdrain fine aggregate shall meet Class III select material, Type 1 or Type 3.

Page 10-63, Article 1044-2, line 2, delete the sentence and replace with the following:

Subdrain coarse aggregate shall meet Class V select material.

SHOULDER AND SLOPE BORROW:

(3-19-13)

1019

SP10 R10

Use soil in accordance with Section 1019 of the *2012 Standard Specifications*. Use soil consisting of loose, friable, sandy material with a PI greater than 6 and less than 25 and a pH ranging from 5.5 to 7.0.

Soil with a pH ranging from 4.0 to 5.5 will be accepted without further testing if additional limestone is provided in accordance with the application rates shown in Table 1019-1A. Soil type is identified during the soil analysis. Soils with a pH above 7.0 require acidic amendments to be added. Submit proposed acidic amendments to the Engineer for review and approval. Soils with a pH below 4.0 or that do not meet the PI requirements shall not be used.

| pH TEST RESULT | Sandy Soils Additional Rate (lbs. / Acre) | Silt Loam Soils Additional Rate (lbs. / Acre) | Clay Loam Soils Additional Rate (lbs. / Acre) |
|-----------------------|--|--|--|
| 4.0 - 4.4 | 1,000 | 4,000 | 6,000 |
| 4.5 - 4.9 | 500 | 3,000 | 5,000 |
| 5.0 - 5.4 | NA | 2,000 | 4,000 |

Note: Limestone application rates shown in this table are in addition to the standard rate of 4000 lbs. / acre required for seeding and mulching.

No direct payment will be made for providing additional lime or acidic amendments for Ph adjustment.

GROUT PRODUCTION AND DELIVERY:

(3-17-15)

1003

SP10 R20

Revise the *2012 Standard Specifications* as follows:

Replace Section 1003 with the following:

**SECTION 1003
GROUT PRODUCTION AND DELIVERY**

1003-1 DESCRIPTION

This section addresses cement grout to be used for structures, foundations, retaining walls, concrete barriers, embankments, pavements and other applications in accordance with the contract. Produce non-metallic grout composed of Portland cement and water and at the Contractor's option or as required, aggregate and pozzolans. Include chemical admixtures as required or needed. Provide sand cement or neat cement grout as required. Define "sand cement grout" as grout with only fine aggregate and "neat cement grout" as grout without aggregate.

The types of grout with their typical uses are as shown below:

Type 1 – A cement grout with only a 3-day strength requirement and a fluid consistency that is typically used for filling subsurface voids.

Type 2 – A nonshrink grout with strength, height change and flow conforming to ASTM C1107 that is typically used for foundations, ground anchors and soil nails.

Type 3 – A nonshrink grout with high early strength and freeze-thaw durability requirements that is typically used in pile blockouts, grout pockets, shear keys, dowel holes and recesses for concrete barriers and structures.

Type 4 – A neat cement grout with low strength, a fluid consistency and high fly ash content that is typically used for slab jacking.

Type 5 – A low slump, low mobility sand cement grout with minimal strength that is typically used for compaction grouting.

1003-2 MATERIALS

Refer to Division 10.

| Item | Section |
|--------------------------------------|----------------|
| Chemical Admixtures | 1024-3 |
| Fine Aggregate | 1014-1 |
| Fly Ash | 1024-5 |
| Ground Granulated Blast Furnace Slag | 1024-6 |
| Portland Cement | 1024-1 |
| Silica Fume | 1024-7 |
| Water | 1024-4 |

Do not use grout that contains soluble chlorides or more than 1% soluble sulfate. At the Contractor's option, use an approved packaged grout instead of the materials above except for water. Use packaged grouts that are on the NCDOT Approved Products List.

Use admixtures for grout that are on the NCDOT Approved Products List or other admixtures in accordance with Subarticle 1024-3(E) except do not use concrete additives or unclassified or other admixtures in Type 4 or 5 grout. Use Class F fly ash for Type 4 grout and Type II Portland cement for Type 5 grout.

Use well graded rounded aggregate with a gradation, liquid limit (LL) and plasticity index (PI) that meet Table 1003-1 for Type 5 grout. Fly ash may be substituted for a portion of the fines in the aggregate. Do not use any other pozzolans in Type 5 grout.

| Gradation | | Maximum Liquid Limit | Maximum Plasticity Index |
|--|---|---------------------------------|-------------------------------------|
| Sieve Designation per AASHTO M 92 | Percentage Passing (% by weight) | | |
| 3/8" | 100 | N/A | N/A |
| No. 4 | 70 – 95 | | |
| No. 8 | 50 – 90 | | |
| No. 16 | 30 – 80 | | |
| No. 30 | 25 – 70 | | |
| No. 50 | 20 – 50 | | |
| No. 100 | 15 – 40 | | |
| No. 200 | 10 – 30 | 25 | 10 |

1003-3 COMPOSITION AND DESIGN

When using an approved packaged grout, a grout mix design submittal is not required. Otherwise, submit proposed grout mix designs for each grout mix to be used in the work. Mixes for all grout shall be designed by a Certified Concrete Mix Design Technician or an Engineer licensed by the State of North Carolina. Mix proportions shall be determined by a testing laboratory approved by the Department. Base grout mix designs on laboratory trial batches that meet Table 1003-2 and this section. With permission, the Contractor may use a quantity of chemical admixture within the range shown on the current list of approved admixtures maintained by the Materials and Tests Unit.

Submit grout mix designs in terms of saturated surface dry weights on Materials and Tests Form 312U at least 35 days before proposed use. Adjust batch proportions to compensate for surface moisture contained in the aggregates at the time of batching. Changes in the saturated surface dry mix proportions will not be permitted unless revised grout mix designs have been submitted to the Engineer and approved.

Accompany Materials and Tests Form 312U with a listing of laboratory test results of compressive strength, density and flow or slump and if applicable, aggregate gradation, durability and height change. List the compressive strength of at least three 2" cubes at the age of 3 and 28 days.

The Engineer will review the grout mix design for compliance with the contract and notify the Contractor as to its acceptability. Do not use a grout mix until written notice has been received. Acceptance of the grout mix design or use of approved packaged grouts does not relieve the Contractor of his responsibility to furnish a product that meets the contract. Upon written request from the Contractor, a grout mix design accepted and used satisfactorily on any Department project may be accepted for use on other projects.

Perform laboratory tests in accordance with the following test procedures:

| Property | Test Method |
|----------------------------------|--|
| Aggregate Gradation ^A | AASHTO T 27 |
| Compressive Strength | AASHTO T 106 |
| Density (Unit Weight) | AASHTO T 121, AASHTO T 133 ^B , ANSI/API RPC 13B-1 ^B (Section 4, Mud Balance) |
| Durability | AASHTO T 161 ^D |
| Flow | ASTM C939 (Flow Cone) |
| Height Change | ASTM C1090 ^E |
| Slump | AASHTO T 119 |

- A.** Applicable to grout with aggregate.
- B.** Applicable to Neat Cement Grout.
- C.** American National Standards Institute/American Petroleum Institute Recommended Practice.
- D.** Procedure A (Rapid Freezing and Thawing in Water) required.
- E.** Moist room storage required.

1003-4 GROUT REQUIREMENTS

Provide grout types in accordance with the contract. Use grouts with properties that meet Table 1003-2. The compressive strength of the grout will be considered the average compressive strength test results of three 2" cubes at each age. Make cubes that meet AASHTO T 106 from the grout delivered for the work or mixed on-site. Make cubes at such frequencies as the Engineer may determine and cure them in accordance with AASHTO T 106.

**TABLE 1003-2
GROUT REQUIREMENTS**

| Type of Grout | Minimum Compressive Strength at | | Height Change at 28 days | Flow ^A /Slump ^B | Minimum Durability Factor |
|----------------|---------------------------------|-----------|--------------------------|---|---------------------------|
| | 3 days | 28 days | | | |
| 1 | 3,000 psi | – | – | 10 – 30 sec | – |
| 2 | Table 1 ^C | | | Fluid Consistency ^C | – |
| 3 | 5,000 psi | – | 0 – 0.2% | Per Accepted Grout Mix Design/ Approved Packaged Grout | 80 |
| 4 ^D | 600 psi | 1,500 psi | – | 10 – 26 sec | – |
| 5 | – | 500 psi | – | 1 – 3" | – |

A. Applicable to Type 1 through 4 grouts.

B. Applicable to Type 5 grout.

C. ASTM C1107.

D. Use Type 4 grout with proportions by volume of 1 part cement and 3 parts fly ash.

1003-5 TEMPERATURE REQUIREMENTS

When using an approved packaged grout, follow the manufacturer's instructions for grout and air temperature at the time of placement. Otherwise, the grout temperature at the time of placement shall be not less than 50°F nor more than 90°F. Do not place grout when the air temperature measured at the location of the grouting operation in the shade away from artificial heat is below 40°F.

1003-6 ELAPSED TIME FOR PLACING GROUT

Agitate grout continuously before placement. Regulate the delivery so the maximum interval between the placing of batches at the work site does not exceed 20 minutes. Place grout before exceeding the times in Table 1003-3. Measure the elapsed time as the time between adding the mixing water to the grout mix and placing the grout.

**TABLE 1003-3
ELAPSED TIME FOR PLACING GROUT
(with continuous agitation)**

| Air or Grout Temperature, Whichever is Higher | Maximum Elapsed Time | |
|---|-----------------------------|--------------------------|
| | No Retarding Admixture Used | Retarding Admixture Used |
| 90°F or above | 30 minutes | 1 hr. 15 minutes |
| 80°F through 89°F | 45 minutes | 1 hr. 30 minutes |
| 79°F or below | 60 minutes | 1 hr. 45 minutes |

1003-7 MIXING AND DELIVERY

Use grout free of any lumps and undispersed cement. When using an approved packaged grout, mix grout in accordance with the manufacturer's instructions. Otherwise, comply with Articles 1000-8 through 1000-12 to the extent applicable for grout instead of concrete.

GEOSYNTHETICS:

(2-16-16)

1056

SP10 R25

Revise the *2012 Standard Specifications* as follows:

Replace Section 1056 with the following:

**SECTION 1056
GEOSYNTHETICS****1056-1 DESCRIPTION**

Provide geosynthetics for subsurface drainage, separation, stabilization, reinforcement, erosion control, filtration and other applications in accordance with the contract. Use geotextiles, geocomposite drains and geocells that are on the NCDOT Approved Products List. Prefabricated geocomposite drains include sheet, strip and vertical drains (PVDs), i.e., "wick drains" consisting of a geotextile attached to and/or encapsulating a plastic drainage core. Geocells are comprised of ultrasonically welded polymer strips that when expanded form a 3D honeycomb grid that is typically filled with material to support vegetation.

If necessary or required, hold geotextiles and sheet drains in place with new wire staples, i.e., "sod staples" that meet Subarticle 1060-8(D) or new anchor pins. Use steel anchor pins with a diameter of at least 3/16" and a length of at least 18" and with a point at one end and a head at the other end that will retain a steel washer with an outside diameter of at least 1.5".

1056-2 HANDLING AND STORING

Load, transport, unload and store geosynthetics so geosynthetics are kept clean and free of damage. Label, ship and store geosynthetics in accordance with Section 7 of AASHTO M 288. Geosynthetics with defects, flaws, deterioration or damage will be rejected. Do not unwrap geosynthetics until just before installation. Do not leave geosynthetics exposed for more than 7 days before covering except for geosynthetics for temporary wall faces and erosion control.

1056-3 CERTIFICATIONS

Provide Type 1, Type 2 or Type 4 material certifications in accordance with Article 106-3 for geosynthetics. Define "minimum average roll value" (MARV) in accordance with ASTM D4439. Provide certifications with MARV for geosynthetic properties as required. Test geosynthetics using laboratories accredited by the Geosynthetic Accreditation Institute (GAI) to perform the required test methods. Sample geosynthetics in accordance with ASTM D4354.

1056-4 GEOTEXTILES

When required, sew geotextiles together in accordance with Article X1.1.4 of AASHTO M 288. Provide sewn seams with seam strengths meeting the required strengths for the geotextile type and class specified.

Provide geotextile types and classes in accordance with the contract. Geotextiles will be identified by the product name printed directly on the geotextile. When geotextiles are not marked with a product name or marked with only a manufacturing plant identification code, geotextiles will be identified by product labels attached to the geotextile wrapping. When identification is based on labels instead of markings, unwrap geotextiles just before use in the presence of the Engineer to confirm that the product labels on both ends of the outside of the geotextile outer wrapping match the labels affixed to both ends of the inside of the geotextile roll core. Partial geotextile rolls without the product name printed on the geotextile or product labels affixed to the geotextile roll core may not be used.

Use woven or nonwoven geotextiles with properties that meet Table 1056-1. Define “machine direction” (MD) and “cross-machine direction” (CD) in accordance with ASTM D4439.

| TABLE 1056-1 GEOTEXTILE REQUIREMENTS | | | | | | |
|---|--|---|---------------------------|--------------------------------|--|--------------------|
| Property | Requirement | | | | | Test Method |
| | Type 1 | Type 2 | Type 3^A | Type 4 | Type 5^B | |
| <i>Typical Application</i> | <i>Shoulder Drains</i> | <i>Under Rip Rap</i> | <i>Silt Fence Fabric</i> | <i>Soil Stabilization</i> | <i>Temporary Walls</i> | |
| Elongation (MD & CD) | ≥ 50% | ≥ 50% | ≤ 25% | < 50% | < 50% | ASTM D4632 |
| Grab Strength (MD & CD) | Table 1 ^D , Class 3 | Table 1 ^D , Class 1 | 100 lb ^C | Table 1 ^D , Class 3 | – | ASTM D4632 |
| Tear Strength (MD & CD) | | | – | | | ASTM D4533 |
| Puncture Strength | | | – | | | ASTM D6241 |
| Ultimate Tensile Strength (MD & CD) | – | – | – | – | 2,400 lb/ft ^C (unless required otherwise in the contract) | ASTM D4595 |
| Permittivity | Table 2 ^D , 15% to 50% <i>in Situ</i> Soil Passing 0.075 mm | Table 6 ^D , 15% to 50% <i>in Situ</i> Soil Passing 0.075mm | Table 7 ^D | Table 5 ^D | 0.20 sec ^{-1.C} | ASTM D4491 |
| Apparent Opening Size | | | | | 0.60 mm ^E | ASTM D4751 |
| UV Stability (Retained Strength) | | | | | 70% ^C (after 500 hr of exposure) | ASTM D4355 |

- A. Minimum roll width of 36" required.
 B. Minimum roll width of 13 ft required.
 C. MARV per Article 1056-3.
 D. AASHTO M 288.
 E. Maximum average roll value.

1056-5 GEOCOMPOSITE DRAINS

Provide geocomposite drain types in accordance with the contract and with properties that meet Table 1056-2.

| TABLE 1056-2 GEOCOMPOSITE DRAIN REQUIREMENTS | | | | |
|---|---|--------------------|-------------------|--------------------|
| Property | Requirement | | | Test Method |
| | Sheet Drain | Strip Drain | Wick Drain | |
| Width | ≥ 12" (unless required otherwise in the contract) | 12" ±1/4" | 4" ±1/4" | N/A |

| | | | | |
|--|---|--|---|---------------|
| In-Plane Flow Rate ^A (with gradient of 1.0 and 24-hour seating period) | 6 gpm/ft @ applied normal compressive stress of 10 psi | 15 gpm/ft @ applied normal compressive stress of 7.26 psi | 1.5 gpm ^B @ applied normal compressive stress of 40 psi | ASTM D4716 |
|--|---|--|---|---------------|

A. MARV per Article 1056-3.

B. Per 4" drain width.

For sheet and strip drains, use accessories (e.g., pipe outlets, connectors, fittings, etc.) recommended by the Drain Manufacturer. Provide sheet and strip drains with Type 1 geotextiles heat bonded or glued to HDPE, polypropylene or high impact polystyrene drainage cores that meet Table 1056-3.

| Property | Requirement (MARV) | | Test Method |
|----------------------|--------------------|-------------|---------------------|
| | Sheet Drain | Strip Drain | |
| Thickness | 1/4" | 1" | ASTM D1777 or D5199 |
| Compressive Strength | 40 psi | 30 psi | ASTM D6364 |

For wick drains with a geotextile wrapped around a corrugated drainage core and seamed to itself, use drainage cores with an ultimate tensile strength of at least 225 lb per 4" width in accordance with ASTM D4595 and geotextiles with properties that meet Table 1056-4.

| Property | Requirement | Test Method |
|-------------------------------------|---|-------------|
| Elongation | ≥ 50% | ASTM D4632 |
| Grab Strength | Table 1 ^A , Class 3 | ASTM D4632 |
| Tear Strength | | ASTM D4533 |
| Puncture Strength | | ASTM D6241 |
| Permittivity | 0.7 sec ⁻¹ . ^B | ASTM D4491 |
| Apparent Opening Size (AOS) | Table 2 ^A , | ASTM D4751 |
| UV Stability (Retained Strength) | > 50% <i>in Situ</i> Soil Passing 0.075 mm | ASTM D4355 |

A. AASHTO M 288.

B. MARV per Article 1056-3.

For wick drains with a geotextile fused to both faces of a corrugated drainage core along the peaks of the corrugations, use wick drains with an ultimate tensile strength of at least 1,650 lb/ft in accordance with ASTM D4595 and geotextiles with a permittivity, AOS and UV stability that meet Table 1056-4.

1056-6 GEOCELLS

Geocells will be identified by product labels attached to the geocell wrapping. Unwrap geocells just before use in the presence of the Engineer. Previously opened geocell products will be rejected.

Manufacture geocells from virgin polyethylene resin with no more than 10% rework, also called “regrind”, materials. Use geocells made from textured and perforated HDPE strips with an open area of 10% to 20% and properties that meet Table 1056-5.

| Property | Minimum Requirement | Test Method |
|---|----------------------------|--|
| Cell Depth | 4" | N/A |
| Sheet Thickness | 50 mil -5%, +10% | ASTM D5199 |
| Density | 58.4 lb/cf | ASTM D1505 |
| Carbon Black Content | 1.5% | ASTM D1603 or D4218 |
| ESCR ^A | 5000 hr | ASTM D1693 |
| Coefficient of Direct Sliding (with material that meets AASHTO M 145 for soil classification A-2) | 0.85 | ASTM D5321 |
| Short-Term Seam (Peel) Strength (for 4" seam) | 320 lb | USACE ^C Technical Report GL-86-19, Appendix A |
| Long-Term Seam (Hang) Strength ^B (for 4" seam) | 160 lb | |

A. Environmental Stress Crack Resistance.

B. Minimum test period of 168 hr with a temperature change from 74°F to 130°F in 1-hour cycles.

C. US Army Corps of Engineers.

Provide geocell accessories (e.g., stakes, pins, clips, staples, rings, tendons, anchors, deadmen, etc.) recommended by the Geocell Manufacturer.

SELECT MATERIAL, CLASS VI:**Description**

Place Select Material, Class VI where designated on the plans and as directed by the Engineer.

Material**Item**

Select Material, Class VI

Section

1016-3

Construction Methods

Place Select Material, Class VI as indicated in the plans and as directed by the Engineer.

Measurement and Payment

Select Material, Class VI will be measured and paid for per ton of *Select Material, Class VI* satisfactorily placed and accepted.

Payment will be made under:

Pay Item

Select Material, Class VI

Pay Unit

Ton

TEMPORARY SHORING:

(2-20-07) (Rev. 3-17-15)

SP11 R02

Description

Temporary shoring includes cantilever, braced and anchored shoring and temporary mechanically stabilized earth (MSE) walls. Temporary shoring does not include trench boxes. At the Contractor's option, use any type of temporary shoring unless noted otherwise in the plans or as directed. Design and construct temporary shoring based on actual elevations and shoring dimensions in accordance with the contract and accepted submittals. Construct temporary shoring at locations shown in the plans and as directed. Temporary shoring is required to maintain traffic when a 2:1 (H:V) slope from the top of an embankment or bottom of an excavation will intersect the existing ground line less than 5 ft from the edge of pavement of an open travelway. This provision does not apply to pipe, inlet or utility installation unless noted otherwise in the plans.

Positive protection includes concrete barrier and temporary guardrail. Provide positive protection for temporary shoring at locations shown in the plans and as directed. Positive protection is required if temporary shoring is located in the clear zone in accordance with the *AASHTO Roadside Design Guide*.

(A) Cantilever and Braced Shoring

Cantilever shoring consists of steel sheet piles or H-piles with timber lagging. Braced shoring consists of sheet piles or H-piles with timber lagging and bracing such as beams, plates, walers, struts, rakers, etc. Define "piles" as sheet piles or H-piles.

(B) Anchored Shoring

Anchored shoring consists of sheet piles with walers or H-piles with timber lagging anchored with ground or helical anchors. Driven anchors may be accepted at the discretion of the Engineer. A ground anchor consists of a grouted steel bar or multi-strand tendon with an anchorage. A helical anchor consists of a lead section with a central steel shaft and at least one helix steel plate followed by extensions with only central shafts (no helixes) and an anchorage. Anchorages consist of steel bearing plates with washers and hex nuts for bars or steel wedge plates and wedges for strands. Use a prequalified Anchored Wall Contractor to install ground anchors. Define "anchors" as ground, helical or driven anchors.

(C) Temporary MSE Walls

Temporary MSE walls include temporary geosynthetic and wire walls. Define “temporary wall” as a temporary MSE wall. Define “reinforcement” as geotextile, geogrid, welded wire grid or metallic strip reinforcement.

Temporary geosynthetic walls consist of geotextile or geogrid reinforcement wrapped behind welded wire facing. Define “temporary geotextile wall” as a temporary geosynthetic wall with geotextile reinforcement and “temporary geogrid wall” as a temporary geosynthetic wall with geogrid reinforcement.

Temporary wire walls consist of welded wire grid or metallic strip reinforcement connected to welded wire facing. Define “Wire Wall Vendor” as the vendor supplying the temporary wire wall.

(D) Embedment

Define “embedment” for cantilever, braced and anchored shoring as the pile depth below the grade in front of shoring. Define “embedment” for temporary walls as the wall height below the grade in front of walls.

(E) Positive Protection

Define “unanchored or anchored portable concrete barrier” as portable concrete barrier (PCB) that meets Standard Drawing No. 1170.01 of the *2012 Roadway Standard Drawings*. Define “concrete barrier” as unanchored or anchored PCB or an approved equal. Define “temporary guardrail” as temporary steel beam guardrail that meets Standard Drawing No. 862.02 of the *2012 Roadway Standard Drawings*.

Materials

Refer to the *2012 Standard Specifications*.

| Item | Section |
|--------------------------------|----------------|
| Anchor Pins | 1056-2 |
| Concrete Barrier Materials | 1170-2 |
| Flowable Fill, Excavatable | 1000-6 |
| Geotextiles | 1056 |
| Grout | 1003 |
| Portland Cement Concrete | 1000 |
| Select Material | 1016 |
| Steel Beam Guardrail Materials | 862-2 |
| Steel Plates | 1072-2 |
| Steel Sheet Piles and H-Piles | 1084 |
| Untreated Timber | 1082-2 |
| Welded Wire Reinforcement | 1070-3 |
| Wire Staples | 1060-8(D) |

Provide Type 6 material certifications for shoring materials in accordance with Article 106-3 of the *2012 Standard Specifications*. Use Class IV select material (standard size No. ABC) for temporary guardrail. Use neat cement grout for Type 2 grout for ground anchors. Use Class A concrete that meets Article 450-2 of the *2012 Standard Specifications* or Type 1 grout for drilled-in piles. Provide untreated timber with a thickness of at least 3" and a bending stress of at least 1,000 psi for timber lagging. Provide steel bracing that meets ASTM A36.

(A) Shoring Backfill

Use Class II, Type 1, Class III, Class V or Class VI select material or material that meets AASHTO M 145 for soil classification A-2-4 with a maximum PI of 6 for shoring backfill except do not use A-2-4 soil for backfill around culverts.

(B) Anchors

Store anchor materials on blocking a minimum of 12" above the ground and protect it at all times from damage; and when placing in the work make sure it is free from dirt, dust, loose mill scale, loose rust, paint, oil or other foreign materials. Load, transport, unload and store anchor materials so materials are kept clean and free of damage. Bent, damaged or defective materials will be rejected.

(1) Ground Anchors

Use high-strength deformed steel bars that meet AASHTO M 275 or seven-wire strands that meet ASTM A886 or Article 1070-5 of the *2012 Standard Specifications*. Splice bars in accordance with Article 1070-9 of the *2012 Standard Specifications*. Do not splice strands. Use bondbreakers, spacers and centralizers that meet Article 6.3.5 of the *AASHTO LRFD Bridge Construction Specifications*.

(2) Helical Anchors

Use helical anchors with an ICC Evaluation Service, Inc. (ICC-ES) report. Helical anchors without an ICC-ES report may be approved at the discretion of the Engineer. Provide couplers, thread bar adapters and bolts recommended by the Anchor Manufacturer to connect helical anchors together and to piles.

(3) Anchorages

Provide steel plates for bearing plates and steel washers, hex nuts, wedge plates and wedges recommended by the Anchor Manufacturer.

(C) Temporary Walls

(1) Welded Wire Facing

Use welded wire reinforcement for welded wire facing, struts and wires. For temporary wire walls, provide welded wire facing supplied by the Wire Wall Vendor or a manufacturer approved or licensed by the vendor. For temporary wire

walls with separate reinforcement and facing components, provide connectors (e.g., bars, clamps, plates, etc.) and fasteners (e.g., bolts, nuts, washers, etc.) required by the Wire Wall Vendor.

(2) Geotextiles

Provide Type 2 geotextile for separation and retention geotextiles. Provide Type 5 geotextile for geotextile reinforcement with ultimate tensile strengths in accordance with the accepted submittals.

(3) Geogrid Reinforcement

Handle and store geogrids in accordance with Article 1056-2 of the *2012 Standard Specifications*. Define “machine direction” (MD) and “cross-machine direction” (CD) for geogrids in accordance with ASTM D4439.

Use geogrids with a roll width of at least 4 ft and an “approved” or “approved for provisional use” status code. The list of approved geogrids is available from: connect.ncdot.gov/resources/Materials/Pages/SoilsLaboratory.aspx

Provide geogrids for geogrid reinforcement with design strengths in accordance with the accepted submittals. Geogrids are typically approved for ultimate tensile strengths in the MD and CD or short-term design strengths for a 3-year design life in the MD based on material type. Define material type from the website above for shoring backfill as follows:

| Material Type | Shoring Backfill |
|----------------------|---|
| Borrow | A-2-4 Soil |
| Fine Aggregate | Class II, Type 1 or Class III Select Material |
| Coarse Aggregate | Class V or VI Select Material |

(4) Welded Wire Grid and Metallic Strip Reinforcement

Provide welded wire grid and metallic strip reinforcement supplied by the Wire Wall Vendor or a manufacturer approved or licensed by the vendor. Use welded wire grid reinforcement (“mesh”, “mats” and “ladders”) that meet Article 1070-3 of the *2012 Standard Specifications* and metallic strip reinforcement (“straps”) that meet ASTM A572 or A1011.

Preconstruction Requirements

(A) Concrete Barrier

Define “clear distance” behind concrete barrier as the horizontal distance between the barrier and edge of pavement. The minimum required clear distance for concrete barrier is shown in the plans. At the Contractor’s option or if the minimum required clear distance is not available, set concrete barrier next to and up against traffic side of temporary shoring

except for barrier above temporary walls. Concrete barrier with the minimum required clear distance is required above temporary walls.

(B) Temporary Guardrail

Define “clear distance” behind temporary guardrail as the horizontal distance between guardrail posts and temporary shoring. At the Contractor’s option or if clear distance for cantilever, braced and anchored shoring is less than 4 ft, attach guardrail to traffic side of shoring as shown in the plans. Place ABC in clear distance and around guardrail posts instead of pavement. Do not use temporary guardrail above temporary walls.

(C) Temporary Shoring Designs

Before beginning temporary shoring design, survey existing ground elevations in the vicinity of shoring locations to determine actual design heights (H). Submit 8 copies of working drawings and 3 copies of design calculations and a PDF copy of each for temporary shoring designs in accordance with Article 105-2 of the *2012 Standard Specifications*. Submit working drawings showing plan views, shoring profiles, typical sections and details of temporary shoring design and construction sequence. Do not begin shoring construction until a design submittal is accepted.

Have cantilever and braced shoring designed, detailed and sealed by an engineer licensed in the state of North Carolina. Use a prequalified Anchored Wall Design Consultant to design anchored shoring. Provide anchored shoring designs sealed by a Design Engineer approved as a Geotechnical Engineer (key person) for an Anchored Wall Design Consultant. Include details in anchored shoring working drawings of anchor locations and lock-off loads, unit grout/ground bond strengths for ground anchors or minimum installation torque and torsional strength rating for helical anchors and if necessary, obstructions extending through shoring or interfering with anchors. Include details in the anchored shoring construction sequence of pile and anchor installation, excavation and anchor testing.

Use a prequalified MSE Wall Design Consultant to design temporary walls. Provide temporary wall designs sealed by a Design Engineer approved as a Geotechnical Engineer (key person) for the MSE Wall Design Consultant. Include details in temporary wall working drawings of geotextile and reinforcement types, locations and directions and obstructions extending through walls or interfering with reinforcement.

(1) Soil Parameters

Design temporary shoring for the assumed soil parameters and groundwater elevations shown in the plans. Assume the following soil parameters for shoring backfill:

- (a) Unit weight (γ) = 120 lb/cf;

| | | |
|-----|---|---|
| (b) | Friction Angle (ϕ) | Shoring Backfill |
| | 30° | A-2-4 Soil |
| | 34° | Class II, Type 1 or Class III Select Material |
| | 38° | Class V or VI Select Material |

(c) Cohesion (c) = 0 lb/sf.

(2) Traffic Surcharge

Design temporary shoring for a traffic surcharge of 250 lb/sf if traffic will be above and within H of shoring. This traffic surcharge does not apply to construction traffic. Design temporary shoring for any construction surcharge if construction traffic will be above and within H of shoring. For LRFD shoring designs, apply traffic (live load) surcharge in accordance with Figure C11.5.5-3 of the *AASHTO LRFD Bridge Design Specifications*.

(3) Cantilever, Braced and Anchored Shoring Designs

Use shoring backfill for fill sections and voids between cantilever, braced and anchored shoring and the critical failure surface. Use concrete or grout for embedded portions of drilled-in H-piles. Do not use drilled-in sheet piles.

Define “top of shoring” for cantilever, braced and anchored shoring as where the grade intersects the back of sheet piles or H-piles and timber lagging. Design cantilever, braced and anchored shoring for a traffic impact load of 2,000 lb/ft applied 18" above top of shoring if concrete barrier is above and next to shoring or temporary guardrail is above and attached to shoring. For anchored shoring designs, apply traffic impact load as horizontal load (P_{HI}) in accordance with Figure 3.11.6.3-2(a) of the *AASHTO LRFD specifications*.

Extend cantilever, braced and anchored shoring at least 32" above top of shoring if shoring is designed for traffic impact. Otherwise, extend shoring at least 6" above top of shoring.

Design cantilever, braced and anchored shoring for a maximum deflection of 3" if the horizontal distance to the closest edge of pavement or structure is less than H. Otherwise, design shoring for a maximum deflection of 6". Design cantilever and braced shoring in accordance with the plans and *AASHTO Guide Design Specifications for Bridge Temporary Works*.

Design anchored shoring in accordance with the plans and Article 11.9 of the *AASHTO LRFD Bridge Design Specifications*. Use a resistance factor of 0.80 for tensile resistance of anchors with bars, strands or shafts. Extend the unbonded length for ground anchors and the shallowest helix for helical anchors at least 5 ft behind the critical failure surface. Do not extend anchors beyond right-of-way or easement limits. If existing or future obstructions such as foundations, guardrail posts, pavements, pipes, inlets or utilities will interfere with anchors, maintain a clearance of at least 6" between obstructions and anchors.

(4) Temporary Wall Designs

Use shoring backfill in the reinforced zone of temporary walls. Separation geotextiles are required between shoring backfill and backfill, natural ground or culverts along the sides of the reinforced zone perpendicular to the wall face. For Class V or VI select material in the reinforced zone, separation geotextiles are also required between shoring backfill and backfill or natural ground on top of and at the back of the reinforced zone.

Design temporary walls in accordance with the plans and Article 11.10 of the *AASHTO LRFD Bridge Design Specifications*. Embed temporary walls at least 18" except for walls on structures or rock as determined by the Engineer. Use a uniform reinforcement length throughout the wall height of at least 0.7H or 6 ft, whichever is longer. Extend the reinforced zone at least 6" beyond end of reinforcement. Do not locate the reinforced zone outside right-of-way or easement limits.

Use the simplified method for determining maximum reinforcement loads in accordance with the AASHTO LRFD specifications. For geotextile reinforcement, use geotextile properties approved by the Department or default values in accordance with the AASHTO LRFD specifications. For geogrid reinforcement, use approved geogrid properties available from the website shown elsewhere in this provision. If the website does not list a short-term design strength for an approved geogrid, use a short-term design strength equal to the ultimate tensile strength divided by 3.5 for the geogrid reinforcement. Use geosynthetic properties for the direction reinforcement will be installed, a 3-year design life and shoring backfill to be used in the reinforced zone.

Do not use more than 4 different reinforcement strengths for each temporary geosynthetic wall. Design temporary geotextile walls for a reinforcement coverage ratio (R_c) of 1.0 and temporary geogrid walls for an R_c of at least 0.8. For geogrid reinforcement with an R_c of less than 1.0, use a maximum horizontal clearance between geogrids of 3 ft and stagger reinforcement so geogrids are centered over gaps in the reinforcement layer below.

For temporary geosynthetic walls, use "L" shaped welded wire facing with 18" to 24" long legs. Locate geotextile or geogrid reinforcement so reinforcement layers are at the same level as the horizontal legs of welded wire facing. Use vertical reinforcement spacing equal to facing height. Wrap geotextile or geogrid reinforcement behind welded wire facing and extend reinforcement at least 3 ft back behind facing into shoring backfill.

For temporary wire walls with separate reinforcement and facing components, attach welded wire grid or metallic strip reinforcement to welded wire facing with a connection approved by the Department. For temporary geogrid and wire walls, retain shoring backfill at welded wire facing with retention geotextiles and extend geotextiles at least 3 ft back behind facing into backfill.

(D) Preconstruction Meeting

The Engineer may require a shoring preconstruction meeting to discuss the construction, inspection and testing of the temporary shoring. If required and if this meeting occurs before all shoring submittals have been accepted, additional preconstruction meetings may be required before beginning construction of temporary shoring without accepted submittals. The Resident, District or Bridge Maintenance Engineer, Bridge or Roadway Construction Engineer, Geotechnical Operations Engineer, Contractor and Shoring Contractor Superintendent will attend preconstruction meetings.

Construction Methods

Control drainage during construction in the vicinity of shoring. Direct run off away from shoring and shoring backfill. Contain and maintain backfill and protect material from erosion.

Install positive protection in accordance with the contract and accepted submittals. Use PCB in accordance with Section 1170 of the *2012 Standard Specifications* and Standard Drawing No. 1170.01 of the *2012 Roadway Standard Drawings*. Use temporary guardrail in accordance with Section 862 of the *2012 Standard Specifications* and Standard Drawing No. 862.01, 862.02 and 862.03 of the *2012 Roadway Standard Drawings*.

(A) Tolerances

Construct shoring with the following tolerances:

- (1) Horizontal wires of welded wire facing are level in all directions,
- (2) Shoring location is within 6" of horizontal and vertical alignment shown in the accepted submittals, and
- (3) Shoring plumbness (batter) is not negative and within 2° of vertical.

(B) Cantilever, Braced and Anchored Shoring Installation

If over excavation behind cantilever, braced or anchored shoring is shown in the accepted submittals, excavate before installing piles. Otherwise, install piles before excavating for shoring. Install cantilever, braced or anchored shoring in accordance with the construction sequence shown in the accepted submittals. Remove piles and if applicable, timber lagging when shoring is no longer needed.

(1) Pile Installation

Install piles with the minimum required embedment and extension in accordance with Subarticles 450-3(D) and 450-3(E) of the *2012 Standard Specifications* except that a pile driving equipment data form is not required. Piles may be installed with a vibratory hammer as approved by the Engineer.

Do not splice sheet piles. Use pile excavation to install drilled-in H-piles. After filling holes with concrete or grout to the elevations shown in the accepted submittals, remove any fluids and fill remaining portions of holes with flowable fill. Cure concrete or grout at least 7 days before excavating.

Notify the Engineer if refusal is reached before pile excavation or driven piles attain the minimum required embedment. When this occurs, a revised design submittal may be required.

(2) Excavation

Excavate in front of piles from the top down in accordance with the accepted submittals. For H-piles with timber lagging and braced and anchored shoring, excavate in staged horizontal lifts with a maximum height of 5 ft. Remove flowable fill and material in between H-piles as needed to install timber lagging. Position lagging with at least 3" of contact in the horizontal direction between the lagging and pile flanges. Do not excavate the next lift until timber lagging for the current lift is installed and if applicable, bracing and anchors for the current lift are accepted. Backfill behind cantilever, braced or anchored shoring with shoring backfill.

(3) Anchor Installation

If applicable, install foundations located behind anchored shoring before installing anchors. Fabricate and install ground anchors in accordance with the accepted submittals, Articles 6.4 and 6.5 of the *AASHTO LRFD Bridge Construction Specifications* and the following unless otherwise approved:

- (a) Materials in accordance with this provision are required instead of materials conforming to Articles 6.4 and 6.5.3 of the *AASHTO LRFD Specifications*,
- (b) Encapsulation-protected ground anchors in accordance with Article 6.4.1.2 of the *AASHTO LRFD specifications* are not required, and
- (c) Corrosion protection for unbonded lengths of ground anchors and anchorage covers are not required.
- (d) Measure grout temperature, density and flow during grouting with at least the same frequency grout cubes are made for compressive strength. Perform density and flow field tests in the presence of the Engineer in accordance with American National Standards Institute/American Petroleum Institute Recommended Practice 13B-1 (Section 4, Mud Balance) and ASTM C939 (Flow Cone), respectively.

Install helical anchors in accordance with the accepted submittals and Anchor Manufacturer's instructions. Measure torque during installation and do not exceed the torsional strength rating of the helical anchor. Attain the minimum required installation torque and penetration before terminating anchor installation. When

replacing a helical anchor, embed last helix of the replacement anchor at least 3 helix plate diameters past the location of the first helix of the previous anchor.

(4) Anchor Testing

Proof test and lock-off anchors in accordance with the accepted submittals and Article 6.5.5 of the *AASHTO LRFD Bridge Construction Specifications* except for the acceptance criteria in Article 6.5.5.5. For the AASHTO LRFD specifications, “ground anchor” refers to a ground or helical anchor and “tendon” refers to a bar, strand or shaft.

(a) Anchor Acceptance

Anchor acceptance is based in part on the following criteria.

- (i) For ground and helical anchors, total movement is less than 0.04" between the 1 and 10 minute readings or less than 0.08" between the 6 and 60 minute readings.
- (ii) For ground anchors, total movement at maximum test load exceeds 80% of the theoretical elastic elongation of the unbonded length.

(b) Anchor Test Results

Submit 2 copies of anchor test records including movement versus load plots for each load increment within 24 hours of completing each row of anchors. The Engineer will review the test records to determine if the anchors are acceptable.

If the Engineer determines an anchor is unacceptable, revise the anchor design or installation methods. Submit a revised anchored shoring design for acceptance and provide an acceptable anchor with the revised design or installation methods. If required, replace the anchor or provide additional anchors with the revised design or installation methods.

(C) Temporary Wall Installation

Excavate as necessary for temporary walls in accordance with the plans and accepted submittals. If applicable, install foundations located in the reinforced zone before placing shoring backfill or reinforcement unless otherwise approved. Notify the Engineer when foundation excavation is complete. Do not place shoring backfill or reinforcement until excavation dimensions and foundation material are approved.

Erect welded wire facing so the wall position is as shown in the plans and accepted submittals. Set welded wire facing adjacent to each other in the horizontal and vertical direction to completely cover the wall face with facing. Stagger welded wire facing to create a running bond by centering facing over joints in the row below.

Wrap geotextile reinforcement and retention geotextiles behind welded wire facing as shown in the plans and accepted submittals and cover geotextiles with at least 3" of shoring backfill. Overlap adjacent geotextile reinforcement and retention and separation geotextiles at least 18" with seams oriented perpendicular to the wall face. Hold geotextiles in place with wire staples or anchor pins as needed.

Place reinforcement within 3" of locations shown in the plans and accepted submittals and in slight tension free of kinks, folds, wrinkles or creases. Install reinforcement with the direction shown in the plans and accepted submittals. For temporary wire walls with separate reinforcement and facing components, attach welded wire grid or metallic strip reinforcement to welded wire facing as shown in the accepted submittals. Do not splice or overlap reinforcement so seams are parallel to the wall face. Contact the Engineer when unanticipated existing or future obstructions such as foundations, pavements, pipes, inlets or utilities will interfere with reinforcement.

Place shoring backfill in the reinforced zone in 8" to 10" thick lifts. Compact A-2-4 soil and Class II, Type 1 and Class III select material in accordance with Subarticle 235-3(C) of the *2012 Standard Specifications*. Use only hand operated compaction equipment to compact backfill within 3 ft of welded wire facing. At a distance greater than 3 ft, compact shoring backfill with at least 4 passes of an 8 ton to 10 ton vibratory roller in a direction parallel to the wall face. Smooth wheeled or rubber tired rollers are also acceptable for compacting backfill. Do not use sheepsfoot, grid rollers or other types of compaction equipment with feet. Do not displace or damage reinforcement when placing and compacting shoring backfill. End dumping directly on geotextile or geogrid reinforcement is not permitted. Do not operate heavy equipment on reinforcement until it is covered with at least 8" of shoring backfill. Replace any damaged reinforcement to the satisfaction of the Engineer.

Backfill for temporary walls outside the reinforced zone in accordance with Article 410-8 of the *2012 Standard Specifications*. Bench temporary walls into the sides of excavations where applicable. For temporary geosynthetic walls with top of wall within 5 ft of finished grade, remove top facing and incorporate top reinforcement layer into fill when placing fill in front of wall. Temporary walls remain in place permanently unless otherwise required.

Measurement and Payment

Temporary Shoring will be measured and paid in square feet. Temporary walls will be measured as the square feet of exposed wall face area. Cantilever, braced or anchored shoring will be measured as the square feet of exposed shoring face area with the shoring height equal to the difference between the top and bottom of shoring elevations. Define "top of shoring" as where the grade intersects the back of sheet piles or H-piles and timber lagging. Define "bottom of shoring" as where the grade intersects front of sheet piles or H-piles and timber lagging. No measurement will be made for any embedment, shoring extension above top of shoring or pavement thickness above temporary walls.

The contract unit price for *Temporary Shoring* will be full compensation for providing shoring designs, submittals and materials, excavating, backfilling, hauling and removing excavated

materials and supplying all labor, tools, equipment and incidentals necessary to construct temporary shoring.

No payment will be made for temporary shoring not shown in the plans or required by the Engineer including shoring for OSHA reasons or the Contractor's convenience. No value engineering proposals will be accepted based solely on revising or eliminating shoring locations shown in the plans or estimated quantities shown in the bid item sheets as a result of actual field measurements or site conditions.

PCB will be measured and paid in accordance with Section 1170 of the *2012 Standard Specifications*. No additional payment will be made for anchoring PCB for temporary shoring. Costs for anchoring PCB will be incidental to temporary shoring.

Temporary guardrail will be measured and paid for in accordance with Section 862 of the *2012 Standard Specifications*.

Payment will be made under:

Pay Item
Temporary Shoring

Pay Unit
Square Foot

TRUCK MOUNTED CHANGEABLE MESSAGE SIGNS:

(8-21-12)

1101.02

SP11 R10

Revise the *2012 Roadway Standard Drawings* as follows:

Drawing No. 1101.02, Sheet 12, TEMPORARY LANE CLOSURES, replace General Note #11 with the following:

11- TRUCK MOUNTED CHANGEABLE MESSAGE SIGNS (TMCMS) USED ON SHADOW VEHICLES FOR "IN LANE" ACTIVITIES SHALL BE A MINIMUM OF 43" X 73". THE DISPLAY PANEL SHALL HAVE FULL MATRIX CAPABILITY WITH THE CAPABILITY TO PROVIDE 2 MESSAGE LINES WITH 7 CHARACTERS PER LINE WITH A MINIMUM CHARACTER HEIGHT OF 18". FOR ADDITIONAL MESSAGING, CONTACT THE WORK ZONE TRAFFIC CONTROL SECTION.

12- TMCMS USED FOR ADVANCED WARNING ON VEHICLES LOCATED ON THE SHOULDER MAY BE SMALLER THAN 43" X 73". THE DISPLAY PANEL SHALL HAVE THE CAPABILITY TO PROVIDE 2 MESSAGE LINES WITH 7 CHARACTERS PER LINE WITH A MINIMUM CHARACTER HEIGHT OF 18". FOR ADDITIONAL MESSAGING, CONTACT THE WORK ZONE TRAFFIC CONTROL SECTION.

Drawing No. 1101.02, Sheet 13, TEMPORARY LANE CLOSURES, replace General Note #12 with the following:

12- TRUCK MOUNTED CHANGEABLE MESSAGE SIGNS (TMCMS) USED ON SHADOW VEHICLES FOR "IN LANE" ACTIVITIES SHALL BE A MINIMUM OF 43" X 73". THE DISPLAY PANEL SHALL HAVE FULL MATRIX CAPABILITY WITH THE CAPABILITY TO PROVIDE 2 MESSAGE LINES WITH 7 CHARACTERS PER LINE WITH A MINIMUM

CHARACTER HEIGHT OF 18". FOR ADDITIONAL MESSAGING, CONTACT THE WORK ZONE TRAFFIC CONTROL SECTION.

13- TMCMS USED FOR ADVANCED WARNING ON VEHICLES LOCATED ON THE SHOULDER MAY BE SMALLER THAN 43" X 73". THE DISPLAY PANEL SHALL HAVE THE CAPABILITY TO PROVIDE 2 MESSAGE LINES WITH 7 CHARACTERS PER LINE WITH A MINIMUM CHARACTER HEIGHT OF 18". FOR ADDITIONAL MESSAGING, CONTACT THE WORK ZONE TRAFFIC CONTROL SECTION.

GROUT REFERENCES FOR POSITIVE PROTECTION:

(5-19-15)

1170

SP11 R20

Revise the *2012 Standard Specifications* as follows:

Page 11-14, Article 1170-2, Materials, line 30, in the materials table, replace “Freeze-Thaw Durable Grout, Nonshrink” with “Grout, Type 3”.

Page 11-14, Article 1170-2, Materials, lines 31-32, delete the first paragraph after the materials table.

DUCTILE IRON PIPE FITTINGS:

(01-17-17)

1510, 1515, 1520

SP15 R25

Revise the *2012 Standard Specifications* as follows:

Page 15-7, Article 1510-4 MEASUREMENT AND PAYMENT, add the following paragraph after line 7:

The quantity of *Ductile Iron Water Pipe Fittings* will be measured and paid per pound based on the published weights for ductile iron fittings, exclusive of the weights of any accessories, as listed in the “DI Fittings Weight Chart” located at <https://connect.ncdot.gov/municipalities/Utilities/Pages/Estimates-Materials.aspx>. If the Contractor elects to use compact ductile iron water pipe fittings, measurement will be based on the weight of standard size ductile iron water pipe fittings. Any fitting not listed will be measured based on the published weights for ductile iron fittings listed in ANSI/AWWA C-110/A21.10. This is limited to pressure pipe 4 inches or larger.

Page 15-7, Article 1510-4 MEASUREMENT AND PAYMENT, add the following pay item:

| Pay Item | Pay Unit |
|----------------------------------|-----------------|
| Ductile Iron Water Pipe Fittings | Pound |

Page 15-9, Article 1515-4 MEASUREMENT AND PAYMENT, line 28, delete “fittings”.

Page 15-13, Article 1520-4 MEASUREMENT AND PAYMENT, add the following paragraph after line 2:

The quantity of *Ductile Iron Sewer Pipe Fittings* will be measured and paid per pound based on the published weights for ductile iron fittings, exclusive of the weights of any accessories, as listed in the “DI Fittings Weight Chart” located at <https://connect.ncdot.gov/municipalities/Utilities/Pages/Estimates-Materials.aspx>. If the Contractor elects to use compact ductile iron sewer pipe fittings, measurement will be based on

the weight of standard size ductile iron sewer pipe fittings. Any fitting not listed will be measured based on the published weights for ductile iron fittings listed in ANSI/AWWA C-110/A21.10. This is limited to pressure pipe 4 inches or larger.

Page 15-13, Article 1520-4 MEASUREMENT AND PAYMENT, add the following pay item:

| | |
|----------------------------------|-----------------|
| Pay Item | Pay Unit |
| Ductile Iron Sewer Pipe Fittings | Pound |

PERMANENT SEEDING AND MULCHING:

(7-1-95)

1660

SP16 R02

The Department desires that permanent seeding and mulching be established on this project as soon as practical after slopes or portions of slopes have been graded. As an incentive to obtain an early stand of vegetation on this project, the Contractor's attention is called to the following:

For all permanent seeding and mulching that is satisfactorily completed in accordance with the requirements of Section 1660 in the *2012 Standard Specifications* and within the following percentages of elapsed contract times, an additional payment will be made to the Contractor as an incentive additive. The incentive additive will be determined by multiplying the number of acres of seeding and mulching satisfactorily completed times the contract unit bid price per acre for Seeding and Mulching times the appropriate percentage additive.

| Percentage of Elapsed Contract Time | Percentage Additive |
|-------------------------------------|---------------------|
| 0% - 30% | 30% |
| 30.01% - 50% | 15% |

Percentage of elapsed contract time is defined as the number of calendar days from the date of availability of the contract to the date the permanent seeding and mulching is acceptably completed divided by the total original contract time.

STANDARD SPECIAL PROVISION
AVAILABILITY OF FUNDS – TERMINATION OF CONTRACTS

(5-20-08)

Z-2

General Statute 143C-6-11. (h) Highway Appropriation is hereby incorporated verbatim in this contract as follows:

(h) Amounts Encumbered. – Transportation project appropriations may be encumbered in the amount of allotments made to the Department of Transportation by the Director for the estimated payments for transportation project contract work to be performed in the appropriation fiscal year. The allotments shall be multiyear allotments and shall be based on estimated revenues and shall be subject to the maximum contract authority contained in *General Statute 143C-6-11(c)*. Payment for transportation project work performed pursuant to contract in any fiscal year other than the current fiscal year is subject to appropriations by the General Assembly. Transportation project contracts shall contain a schedule of estimated completion progress, and any acceleration of this progress shall be subject to the approval of the Department of Transportation provided funds are available. The State reserves the right to terminate or suspend any transportation project contract, and any transportation project contract shall be so terminated or suspended if funds will not be available for payment of the work to be performed during that fiscal year pursuant to the contract. In the event of termination of any contract, the contractor shall be given a written notice of termination at least 60 days before completion of scheduled work for which funds are available. In the event of termination, the contractor shall be paid for the work already performed in accordance with the contract specifications.

Payment will be made on any contract terminated pursuant to the special provision in accordance with Subarticle 108-13(E) of the *2012 Standard Specifications*.

STANDARD SPECIAL PROVISION
NCDOT GENERAL SEED SPECIFICATION FOR SEED QUALITY

(5-17-11)

Z-3

Seed shall be sampled and tested by the North Carolina Department of Agriculture and Consumer Services, Seed Testing Laboratory. When said samples are collected, the vendor shall supply an independent laboratory report for each lot to be tested. Results from seed so sampled shall be final. Seed not meeting the specifications shall be rejected by the Department of Transportation and shall not be delivered to North Carolina Department of Transportation warehouses. If seed has been delivered it shall be available for pickup and replacement at the supplier's expense.

Any re-labeling required by the North Carolina Department of Agriculture and Consumer Services, Seed Testing Laboratory, that would cause the label to reflect as otherwise specified herein shall be rejected by the North Carolina Department of Transportation.

Seed shall be free from seeds of the noxious weeds Johnsongrass, Balloonvine, Jimsonweed, Witchweed, Itchgrass, Serrated Tussock, Showy Crotalaria, Smooth Crotalaria, Sicklepod, Sandbur, Wild Onion, and Wild Garlic. Seed shall not be labeled with the above weed species on the seed analysis label. Tolerances as applied by the Association of Official Seed Analysts will NOT be allowed for the above noxious weeds except for Wild Onion and Wild Garlic.

Tolerances established by the Association of Official Seed Analysts will generally be recognized. However, for the purpose of figuring pure live seed, the found pure seed and found germination percentages as reported by the North Carolina Department of Agriculture and Consumer Services, Seed Testing Laboratory will be used. Allowances, as established by the NCDOT, will be recognized for minimum pure live seed as listed on the following pages.

The specifications for restricted noxious weed seed refers to the number per pound as follows:

| <u>Restricted Noxious Weed</u> | <u>Limitations per Lb. Of Seed</u> | <u>Restricted Noxious Weed</u> | <u>Limitations per Lb. of Seed</u> |
|--------------------------------|------------------------------------|--------------------------------|------------------------------------|
| Blessed Thistle | 4 seeds | Cornflower (Ragged Robin) | 27 seeds |
| Cocklebur | 4 seeds | Texas Panicum | 27 seeds |
| Spurred Anoda | 4 seeds | Bracted Plantain | 54 seeds |
| Velvetleaf | 4 seeds | Buckhorn Plantain | 54 seeds |
| Morning-glory | 8 seeds | Broadleaf Dock | 54 seeds |
| Corn Cockle | 10 seeds | Curly Dock | 54 seeds |
| Wild Radish | 12 seeds | Dodder | 54 seeds |
| Purple Nutsedge | 27 seeds | Giant Foxtail | 54 seeds |
| Yellow Nutsedge | 27 seeds | Horsenettle | 54 seeds |
| Canada Thistle | 27 seeds | Quackgrass | 54 seeds |
| Field Bindweed | 27 seeds | Wild Mustard | 54 seeds |
| Hedge Bindweed | 27 seeds | | |

Seed of Pensacola Bahiagrass shall not contain more than 7% inert matter, Kentucky Bluegrass, Centipede and Fine or Hard Fescue shall not contain more than 5% inert matter whereas a maximum of 2% inert matter will be allowed on all other kinds of seed. In addition, all seed shall

not contain more than 2% other crop seed nor more than 1% total weed seed. The germination rate as tested by the North Carolina Department of Agriculture shall not fall below 70%, which includes both dormant and hard seed. Seed shall be labeled with not more than 7%, 5% or 2% inert matter (according to above specifications), 2% other crop seed and 1% total weed seed.

Exceptions may be made for minimum pure live seed allowances when cases of seed variety shortages are verified. Pure live seed percentages will be applied in a verified shortage situation. Those purchase orders of deficient seed lots will be credited with the percentage that the seed is deficient.

FURTHER SPECIFICATIONS FOR EACH SEED GROUP ARE GIVEN BELOW:

Minimum 85% pure live seed; maximum 1% total weed seed; maximum 2% total other crop seed; maximum 144 restricted noxious weed seed per pound. Seed less than 83% pure live seed will not be approved.

Sericea Lespedeza
Oats (seeds)

Minimum 80% pure live seed; maximum 1% total weed seed; maximum 2% total other crop; maximum 144 restricted noxious weed seed per pound. Seed less than 78% pure live seed will not be approved.

| | |
|--------------------------------------|----------------------------|
| Tall Fescue (all approved varieties) | Bermudagrass |
| Kobe Lespedeza | Browntop Millet |
| Korean Lespedeza | German Millet – Strain R |
| Weeping Lovegrass | Clover – Red/White/Crimson |
| Carpetgrass | |

Minimum 78% pure live seed; maximum 1% total weed seed; maximum 2% total other crop seed; maximum 144 restricted noxious weed seed per pound. Seed less than 76% pure live seed will not be approved.

Common or Sweet Sundangrass

Minimum 76% pure live seed; maximum 1% total weed seed; maximum 2% total other crop seed; maximum 144 restricted noxious weed seed per pound. Seed less than 74% pure live seed will not be approved.

Rye (grain; all varieties)
Kentucky Bluegrass (all approved varieties)
Hard Fescue (all approved varieties)
Shrub (bicolor) Lespedeza

Minimum 70% pure live seed; maximum 1% total weed seed; maximum 2% total other crop seed; maximum 144 noxious weed seed per pound. Seed less than 70% pure live seed will not be approved.

| | |
|----------------------|-------------------|
| Centipedegrass | Japanese Millet |
| Crownvetch | Reed Canary Grass |
| Pensacola Bahiagrass | Zoysia |
| Creeping Red Fescue | |

Minimum 70% pure live seed; maximum 1% total weed seed; maximum 2% total other crop seed; maximum 5% inert matter; maximum 144 restricted noxious weed seed per pound.

Barnyard Grass
Big Bluestem
Little Bluestem
Bristly Locust
Birdsfoot Trefoil
Indiangrass
Orchardgrass
Switchgrass
Yellow Blossom Sweet Clover

STANDARD SPECIAL PROVISION**ERRATA**

(1-17-12) (Rev. 04-21-15)

Z-4

Revise the *2012 Standard Specifications* as follows:

Division 2

Page 2-7, line 31, Article 215-2 Construction Methods, replace “Article 107-26” with “Article 107-25”.

Page 2-17, Article 226-3, Measurement and Payment, line 2, delete “pipe culverts,”.

Page 2-20, Subarticle 230-4(B), Contractor Furnished Sources, change references as follows:
Line 1, replace “(4) Buffer Zone” with “(c) Buffer Zone”; **Line 12**, replace “(5) Evaluation for Potential Wetlands and Endangered Species” with “(d) Evaluation for Potential Wetlands and Endangered Species”; and **Line 33**, replace “(6) Approval” with “(4) Approval”.

Division 3

Page 3-1, after line 15, Article 300-2 Materials, replace “1032-9(F)” with “1032-6(F)”.

Division 4

Page 4-77, line 27, Subarticle 452-3(C) Concrete Coping, replace “sheet pile” with “reinforcement”.

Division 6

Page 6-7, line 31, Article 609-3 Field Verification of Mixture and Job Mix Formula Adjustments, replace “30” with “45”.

Page 6-10, line 42, Subarticle 609-6(C)(2), replace “Subarticle 609-6(E)” with “Subarticle 609-6(D)”.

Page 6-11, Table 609-1 Control Limits, replace “Max. Spec. Limit” for the Target Source of $P_{0.075}/P_{be}$ Ratio with “1.0”.

Page 6-40, Article 650-2 Materials, replace “Subarticle 1012-1(F)” with “Subarticle 1012-1(E)”

Division 7

Page 7-1, Article 700-3, CONCRETE HAULING EQUIPMENT, line 33, replace “competition” with “completion”.

Division 8

Page 8-23, line 10, Article 838-2 Materials, replace “Portland Cement Concrete, Class B” with “Portland Cement Concrete, Class A”.

Division 10

Page 10-166, Article 1081-3 Hot Bitumen, replace “Table 1081-16” with “Table 1081-2”, replace “Table 1081-17” with “Table 1081-3”, and replace “Table 1081-18” with “Table 1081-4”.

Division 12

Page 12-7, Table 1205-3, add “FOR THERMOPLASTIC” to the end of the title.

Page 12-8, Subarticle 1205-5(B), line 13, replace “Table 1205-2” with “Table 1205-4”.

Page 12-8, Table 1205-4 and 1205-5, replace “THERMOPLASTIC” in the title of these tables with “POLYUREA”.

Page 12-9, Subarticle 1205-6(B), line 21, replace “Table 1205-4” with “Table 1205-6”.

Page 12-11, Subarticle 1205-8(C), line 25, replace “Table 1205-5” with “Table 1205-7”.

Division 15

Page 15-4, Subarticle 1505-3(F) Backfilling, line 26, replace “Subarticle 235-4(C)” with “Subarticle 235-3(C)”.

Page 15-6, Subarticle 1510-3(B), after line 21, replace the allowable leakage formula with the following: $W=LD\sqrt{P} \div 148,000$

Page 15-6, Subarticle 1510-3(B), line 32, delete “may be performed concurrently or” and replace with “shall be performed”.

Page 15-17, Subarticle 1540-3(E), line 27, delete “Type 1”.

Division 17

Page 17-26, line 42, Subarticle 1731-3(D) Termination and Splicing within Interconnect Center, delete this subarticle.

Revise the *2012 Roadway Standard Drawings* as follows:

1633.01 Sheet 1 of 1, English Standard Drawing for Matting Installation, replace “1633.01” with “1631.01”.

STANDARD SPECIAL PROVISION**PLANT AND PEST QUARANTINES****(Imported Fire Ant, Gypsy Moth, Witchweed, Emerald Ash Borer, And Other Noxious Weeds)**

(3-18-03) (Rev. 12-20-16)

Z-04a

Within Quarantined Area

This project may be within a county regulated for plant and/or pests. If the project or any part of the Contractor's operations is located within a quarantined area, thoroughly clean all equipment prior to moving out of the quarantined area. Comply with federal/state regulations by obtaining a certificate or limited permit for any regulated article moving from the quarantined area.

Originating in a Quarantined County

Obtain a certificate or limited permit issued by the N.C. Department of Agriculture/United States Department of Agriculture. Have the certificate or limited permit accompany the article when it arrives at the project site.

Contact

Contact the N.C. Department of Agriculture/United States Department of Agriculture at 1-800-206-9333, 919-707-3730, or <http://www.ncagr.gov/plantindustry/> to determine those specific project sites located in the quarantined area or for any regulated article used on this project originating in a quarantined county.

Regulated Articles Include

1. Soil, sand, gravel, compost, peat, humus, muck, and decomposed manure, separately or with other articles. This includes movement of articles listed above that may be associated with cut/waste, ditch pulling, and shoulder cutting.
2. Plants with roots including grass sod.
3. Plant crowns and roots.
4. Bulbs, corms, rhizomes, and tubers of ornamental plants.
5. Hay, straw, fodder, and plant litter of any kind.
6. Clearing and grubbing debris.
7. Used agricultural cultivating and harvesting equipment.
8. Used earth-moving equipment.
9. Any other products, articles, or means of conveyance, of any character, if determined by an inspector to present a hazard of spreading imported fire ant, gypsy moth, witchweed, emerald ash borer, or other noxious weeds.

STANDARD SPECIAL PROVISION

MINIMUM WAGES

(7-21-09)

Z-5

FEDERAL: The Fair Labor Standards Act provides that with certain exceptions every employer shall pay wages at the rate of not less than SEVEN DOLLARS AND TWENTY FIVE CENTS (\$7.25) per hour.

STATE: The North Carolina Minimum Wage Act provides that every employer shall pay to each of his employees, wages at a rate of not less than SEVEN DOLLARS AND TWENTY FIVE CENTS (\$7.25) per hour.

The minimum wage paid to all skilled labor employed on this contract shall be SEVEN DOLLARS AND TWENTY FIVE CENTS (\$7.25) per hour.

The minimum wage paid to all intermediate labor employed on this contract shall be SEVEN DOLLARS AND TWENTY FIVE CENTS (\$7.25) per hour.

The minimum wage paid to all unskilled labor on this contract shall be SEVEN DOLLARS AND TWENTY FIVE CENTS (\$7.25) per hour.

This determination of the intent of the application of this act to the contract on this project is the responsibility of the Contractor.

The Contractor shall have no claim against the Department of Transportation for any changes in the minimum wage laws, Federal or State. It is the responsibility of the Contractor to keep fully informed of all Federal and State Laws affecting his contract.

STANDARD SPECIAL PROVISION**AWARD OF CONTRACT**

(6-28-77)(Rev 2/16/2016)

Z-6

“The North Carolina Department of Transportation, in accordance with the provisions of *Title VI of the Civil Rights Act of 1964* (78 Stat. 252) and the Regulations of the Department of Transportation (*49 C.F.R., Part 21*), issued pursuant to such act, hereby notifies all bidders that it will affirmatively insure that the contract entered into pursuant to this advertisement will be awarded to the lowest responsible bidder without discrimination on the ground of race, color, or national origin”.

TITLE VI AND NONDISCRIMINATION**I. Title VI Assurance**

During the performance of this contract, the contractor, for itself, its assignees and successors in interest (hereinafter referred to as the "contractor") agrees as follows:

(1) Compliance with Regulations: The contractor shall comply with the Regulation relative to nondiscrimination in Federally-assisted programs of the Department of Transportation (hereinafter, "DOT") Title 49, Code of Federal Regulations, Part 21, as they may be amended from time to time, (hereinafter referred to as the Regulations), which are herein incorporated by reference and made a part of this contract.

(2) Nondiscrimination: The Contractor, with regard to the work performed by it during the contract, shall not discriminate on the grounds of race, color, or national origin in the selection and retention of subcontractors, including procurements of materials and leases of equipment. The contractor shall not participate either directly or indirectly in the discrimination prohibited by section 21.5 of the Regulations, including employment practices when the contract covers a program set forth in Appendix B of the Regulations.

(3) Solicitations for Subcontractors, Including Procurements of Materials and Equipment: In all solicitations either by competitive bidding or negotiation made by the contractor for work to be performed under a subcontract, including procurements of materials or leases of equipment, each potential subcontractor or supplier shall be notified by the contractor of the contractor's obligations under this contract and the Regulations relative to nondiscrimination on the grounds of race, color, or national origin.

(4) Information and Reports: The contractor shall provide all information and reports required by the Regulations or directives issued pursuant thereto, and shall permit access to its books, records, accounts, other sources of information, and its facilities as may be determined by the North Carolina Department of Transportation (NCDOT) or the Federal Highway Administration (FHWA) to be pertinent to ascertain compliance with such Regulations, orders and instructions. Where any information required of a contractor is in the exclusive possession of another who fails or refuses to furnish this information the contractor shall so certify to the NCDOT, or the FHWA as appropriate, and shall set forth what efforts it has made to obtain the information.

(5) Sanctions for Noncompliance: In the event of the contractor's noncompliance with the nondiscrimination provisions of this contract, the NCDOT shall impose such contract sanctions as it or the FHWA may determine to be appropriate, including, but not limited to:

(a) Withholding of payments to the contractor under the contract until the contractor complies, and/or

(b) Cancellation, termination or suspension of the contract, in whole or in part.

(6) Incorporation of Provisions: The contractor shall include the provisions of paragraphs (1) through (6) in every subcontract, including procurements of materials and leases of equipment, unless exempt by the Regulations, or directives issued pursuant thereto.

The contractor shall take such action with respect to any subcontractor procurement as the NCDOT or the FHWA may direct as a means of enforcing such provisions including sanctions for noncompliance: provided, however, that, in the event a contractor becomes involved in, or is threatened with, litigation with a subcontractor or supplier as a result of such direction, the contractor may request the NCDOT to enter into such litigation to protect the interests of the NCDOT, and, in addition, the contractor may request the United States to enter into such litigation to protect the interests of the United States.

II. Title VI Nondiscrimination Program

Title VI of the 1964 Civil Rights Act, 42 U.S.C. 2000d, provides that: "No person in the United States shall, on the grounds of race, color, or national origin, be excluded from participation in, be denied the benefits of, or be subjected to discrimination under any program or activity receiving Federal financial assistance." The broader application of nondiscrimination law is found in other statutes, executive orders, and regulations (see Section III, Pertinent Nondiscrimination Authorities), which provide additional protections based on age, sex, disability and religion. In addition, the 1987 Civil Rights Restoration Act extends nondiscrimination coverage to all programs and activities of federal-aid recipients and contractors, including those that are not federally-funded.

Nondiscrimination Assurance

The North Carolina Department of Transportation (NCDOT) hereby gives assurance that no person shall on the ground of race, color, national origin, sex, age, and disability, be excluded from participation in, be denied the benefits of, or be otherwise subjected to discrimination under any program or activity conducted by the recipient, as provided by Title VI of the Civil Rights Act of 1964, the Civil Rights Restoration Act of 1987, and any other related Civil Rights authorities, whether those programs and activities are federally funded or not.

Obligation

During the performance of this contract, the Contractor and its subcontractors are responsible for complying with NCDOT's Title VI Program. The Contractor must ensure that NCDOT's Notice of Nondiscrimination is posted in conspicuous locations accessible to all employees and subcontractors on the jobsite, along with the Contractor's own Equal Employment Opportunity (EEO) Policy Statement. The Contractor shall physically incorporate this "**TITLE VI AND NONDISCRIMINATION**" language, in its entirety, into all its subcontracts on federally-assisted and state-funded NCDOT-owned projects, and ensure its inclusion by subcontractors into all subsequent lower tier subcontracts. The Contractor and its subcontractors shall also physically incorporate the **FHWA-1273**, in its entirety, into all subcontracts and subsequent lower tier subcontracts on Federal-aid highway construction contracts only. The Contractor is also responsible for making its subcontractors aware of NCDOT's Discrimination Complaints Process, as follows:

FILING OF COMPLAINTS

1. **Applicability** – These complaint procedures apply to the beneficiaries of the NCDOT’s programs, activities, and services, including, but not limited to, members of the public, contractors, subcontractors, consultants, and other sub-recipients of federal and state funds.
2. **Eligibility** – Any person or class of persons who believes he/she has been subjected to discrimination or retaliation prohibited by any of the Civil Rights authorities, based upon race, color, sex, age, national origin, or disability, may file a written complaint with NCDOT's Civil Rights office. The law prohibits intimidation or retaliation of any sort. The complaint may be filed by the affected individual or a representative, and must be in writing.
3. **Time Limits and Filing Options** – A complaint must be filed no later than 180 calendar days after the following:
 - The date of the alleged act of discrimination; or
 - The date when the person(s) became aware of the alleged discrimination; or
 - Where there has been a continuing course of conduct, the date on which that conduct was discontinued or the latest instance of the conduct.

Title VI and other discrimination complaints may be submitted to the following entities:

- **North Carolina Department of Transportation**, Office of Equal Opportunity & Workforce Services (EOWS), External Civil Rights Section, 1511 Mail Service Center, Raleigh, NC 27699-1511; 919-508-1808 or toll free 800-522-0453
- **US Department of Transportation**, Departmental Office of Civil Rights, External Civil Rights Programs Division, 1200 New Jersey Avenue, SE, Washington, DC 20590; 202-366-4070
 - Federal Highway Administration**, North Carolina Division Office, 310 New Bern Avenue, Suite 410, Raleigh, NC 27601, 919-747-7010
 - Federal Highway Administration**, Office of Civil Rights, 1200 New Jersey Avenue, SE, 8th Floor, E81-314, Washington, DC 20590, 202-366-0693 / 366-0752
 - Federal Transit Administration**, Office of Civil Rights, ATTN: Title VI Program Coordinator, East Bldg. 5th Floor – TCR, 1200 New Jersey Avenue, SE, Washington, DC 20590
 - Federal Aviation Administration**, Office of Civil Rights, 800 Independence Avenue, SW, Washington, DC 20591, 202-267-3258
- **US Department of Justice**, Special Litigation Section, Civil Rights Division, 950 Pennsylvania Avenue, NW, Washington, DC 20530, 202-514-6255 or toll free 877-218-5228

4. **Format for Complaints** – Complaints must be in **writing** and **signed** by the complainant(s) or a representative and include the complainant’s name, address, and telephone number. Complaints received by fax or e-mail will be acknowledged and processed. Allegations received by telephone will be reduced to writing and provided to the complainant for confirmation or revision before processing. Complaints will be accepted in other languages including Braille.
5. **Discrimination Complaint Form** – Contact NCDOT EOWS at the phone number above to receive a full copy of the Discrimination Complaint Form and procedures.
6. **Complaint Basis** – Allegations must be based on issues involving race, color, national origin, sex, age, or disability. The term “basis” refers to the complainant’s membership in a protected group category. Contact this office to receive a Discrimination Complaint Form.

| Protected Categories | Definition | Examples | Applicable Statutes and Regulations | |
|----------------------|--|--|--|--|
| | | | FHWA | FTA |
| Race | An individual belonging to one of the accepted racial groups; or the perception, based usually on physical characteristics that a person is a member of a racial group | Black/African American, Hispanic/Latino, Asian, American Indian/Alaska Native, Native Hawaiian/Pacific Islander, White | Title VI of the Civil Rights Act of 1964; 49 CFR Part 21; 23 CFR 200 | Title VI of the Civil Rights Act of 1964; 49 CFR Part 21; Circular 4702.1B |
| Color | Color of skin, including shade of skin within a racial group | Black, White, brown, yellow, etc. | | |
| National Origin | Place of birth. Citizenship is not a factor. Discrimination based on language or a person's accent is also covered. | Mexican, Cuban, Japanese, Vietnamese, Chinese | | |
| Sex | Gender | Women and Men | 1973 Federal-Aid Highway Act | Title IX of the Education Amendments of 1972 |
| Age | Persons of any age | 21 year old person | Age Discrimination Act of 1975 | |
| Disability | Physical or mental impairment, permanent or temporary, or perceived. | Blind, alcoholic, paraplegic, epileptic, diabetic, arthritic | Section 504 of the Rehabilitation Act of 1973; Americans with Disabilities Act of 1990 | |

III. Pertinent Nondiscrimination Authorities

During the performance of this contract, the contractor, for itself, its assignees, and successors in interest agrees to comply with the following non-discrimination statutes and authorities, including, but not limited to:

- Title VI of the Civil Rights Act of 1964 (42 U.S.C. § 2000d *et seq.*, 78 stat. 252), (prohibits discrimination on the basis of race, color, national origin); and 49 CFR Part 21.
- The Uniform Relocation Assistance and Real Property Acquisition Policies Act of 1970, (42 U.S.C. § 4601), (prohibits unfair treatment of persons displaced or whose property has been acquired because of Federal or Federal-aid programs and projects);
- Federal-Aid Highway Act of 1973, (23 U.S.C. § 324 *et seq.*), (prohibits discrimination on the basis of sex);
- Section 504 of the Rehabilitation Act of 1973, (29 U.S.C. § 794 *et seq.*), as amended, (prohibits discrimination on the basis of disability); and 49 CFR Part 27;
- The Age Discrimination Act of 1975, as amended, (42 U.S.C. § 6101 *et seq.*), (prohibits discrimination on the basis of age);
- Airport and Airway Improvement Act of 1982, (49 USC § 471, Section 47123), as amended, (prohibits discrimination based on race, creed, color, national origin, or sex);
- The Civil Rights Restoration Act of 1987, (PL 100-209), (Broadened the scope, coverage and applicability of Title VI of the Civil Rights Act of 1964, The Age Discrimination Act of 1975 and Section 504 of the Rehabilitation Act of 1973, by expanding the definition of the terms

“programs or activities” to include all of the programs or activities of the Federal-aid recipients, sub-recipients and contractors, whether such programs or activities are Federally funded or not);

- Titles II and III of the Americans with Disabilities Act, which prohibit discrimination on the basis of disability in the operation of public entities, public and private transportation systems, places of public accommodation, and certain testing entities (42 U.S.C. §§ 12131 – 12189) as implemented by Department of Transportation regulations at 49 C.F.R. parts 37 and 38;
- The Federal Aviation Administration’s Non-discrimination statute (49 U.S.C. § 47123) (prohibits discrimination on the basis of race, color, national origin, and sex);
- Executive Order 12898, Federal Actions to Address Environmental Justice in Minority Populations and Low-Income Populations, which ensures discrimination against minority populations by discouraging programs, policies, and activities with disproportionately high and adverse human health or environmental effects on minority and low-income populations;
- Executive Order 13166, Improving Access to Services for Persons with Limited English Proficiency, and resulting agency guidance, national origin discrimination includes discrimination because of limited English proficiency (LEP). To ensure compliance with Title VI, you must take reasonable steps to ensure that LEP persons have meaningful access to your programs (70 Fed. Reg. at 74087 to 74100);
- Title IX of the Education Amendments of 1972, as amended, which prohibits you from discriminating because of sex in education programs or activities (20 U.S.C. 1681 et seq).
- Title VII of the Civil Rights Act of 1964 (42 U.S.C. § 2000e *et seq.*, Pub. L. 88-352), (prohibits employment discrimination on the basis of race, color, religion, sex, or national origin);
- 49 CFR Part 26, regulation to ensure nondiscrimination in the award and administration of DOT-assisted contracts in the Department's highway, transit, and airport financial assistance programs, as regards the use of Disadvantaged Business Enterprises (DBEs);
- Form FHWA-1273, “Required Contract Provisions,” a collection of contract provisions and proposal notices that are generally applicable to *all Federal-aid construction projects* and must be made a part of, and physically incorporated into, *all federally-assisted contracts*, as well as appropriate subcontracts and purchase orders, particularly Sections II (Nondiscrimination) and III (Nonsegregated Facilities).

STANDARD SPECIAL PROVISION**ON-THE-JOB TRAINING**

(10-16-07) (Rev. 4-21-15)

Z-10

Description

The North Carolina Department of Transportation will administer a custom version of the Federal On-the-Job Training (OJT) Program, commonly referred to as the Alternate OJT Program. All contractors (existing and newcomers) will be automatically placed in the Alternate Program. Standard OJT requirements typically associated with individual projects will no longer be applied at the project level. Instead, these requirements will be applicable on an annual basis for each contractor administered by the OJT Program Manager.

On the Job Training shall meet the requirements of 23 CFR 230.107 (b), 23 USC – Section 140, this provision and the On-the-Job Training Program Manual.

The Alternate OJT Program will allow a contractor to train employees on Federal, State and privately funded projects located in North Carolina. However, priority shall be given to training employees on NCDOT Federal-Aid funded projects.

Minorities and Women

Developing, training and upgrading of minorities and women toward journeyman level status is a primary objective of this special training provision. Accordingly, the Contractor shall make every effort to enroll minority and women as trainees to the extent that such persons are available within a reasonable area of recruitment. This training commitment is not intended, and shall not be used, to discriminate against any applicant for training, whether a member of a minority group or not.

Assigning Training Goals

The Department, through the OJT Program Manager, will assign training goals for a calendar year based on the contractors' past three years' activity and the contractors' anticipated upcoming year's activity with the Department. At the beginning of each year, all contractors eligible will be contacted by the Department to determine the number of trainees that will be assigned for the upcoming calendar year. At that time the Contractor shall enter into an agreement with the Department to provide a self-imposed on-the-job training program for the calendar year. This agreement will include a specific number of annual training goals agreed to by both parties. The number of training assignments may range from 1 to 15 per contractor per calendar year. The Contractor shall sign an agreement to fulfill their annual goal for the year.\

Training Classifications

The Contractor shall provide on-the-job training aimed at developing full journeyman level workers in the construction craft/operator positions. Preference shall be given to providing training in the following skilled work classifications:

| | |
|---------------------|----------------------------------|
| Equipment Operators | Office Engineers |
| Truck Drivers | Estimators |
| Carpenters | Iron / Reinforcing Steel Workers |
| Concrete Finishers | Mechanics |
| Pipe Layers | Welders |

The Department has established common training classifications and their respective training requirements that may be used by the contractors. However, the classifications established are not all-inclusive. Where the training is oriented toward construction applications, training will be allowed in lower-level management positions such as office engineers and estimators. Contractors shall submit new classifications for specific job functions that their employees are performing. The Department will review and recommend for acceptance to FHWA the new classifications proposed by contractors, if applicable. New classifications shall meet the following requirements:

Proposed training classifications are reasonable and realistic based on the job skill classification needs, and

The number of training hours specified in the training classification is consistent with common practices and provides enough time for the trainee to obtain journeyman level status.

The Contractor may allow trainees to be trained by a subcontractor provided that the Contractor retains primary responsibility for meeting the training and this provision is made applicable to the subcontract. However, only the Contractor will receive credit towards the annual goal for the trainee.

Where feasible, 25 percent of apprentices or trainees in each occupation shall be in their first year of apprenticeship or training. The number of trainees shall be distributed among the work classifications on the basis of the contractor's needs and the availability of journeymen in the various classifications within a reasonable area of recruitment.

No employee shall be employed as a trainee in any classification in which they have successfully completed a training course leading to journeyman level status or in which they have been employed as a journeyman.

Records and Reports

The Contractor shall maintain enrollment, monthly and completion reports documenting company compliance under these contract documents. These documents and any other information as requested shall be submitted to the OJT Program Manager.

Upon completion and graduation of the program, the Contractor shall provide each trainee with a certification Certificate showing the type and length of training satisfactorily completed.

Trainee Interviews

All trainees enrolled in the program will receive an initial and Trainee/Post graduate interview conducted by the OJT program staff.

Trainee Wages

Contractors shall compensate trainees on a graduating pay scale based upon a percentage of the prevailing minimum journeyman wages (Davis-Bacon Act). Minimum pay shall be as follows:

| | |
|------------|---|
| 60 percent | of the journeyman wage for the first half of the training period |
| 75 percent | of the journeyman wage for the third quarter of the training period |
| 90 percent | of the journeyman wage for the last quarter of the training period |

In no instance shall a trainee be paid less than the local minimum wage. The Contractor shall adhere to the minimum hourly wage rate that will satisfy both the NC Department of Labor (NCDOL) and the Department.

Achieving or Failing to Meet Training Goals

The Contractor will be credited for each trainee employed by him on the contract work who is currently enrolled or becomes enrolled in an approved program and who receives training for at least 50 percent of the specific program requirement. Trainees will be allowed to be transferred between projects if required by the Contractor's scheduled workload to meet training goals.

If a contractor fails to attain their training assignments for the calendar year, they may be taken off the NCDOT's Bidders List.

Measurement and Payment

No compensation will be made for providing required training in accordance with these contract documents.

STANDARD SPECIAL PROVISION

NAME CHANGE FOR NCDENR

(1-19-16)

Z-11

Description

Wherever in the 2012 Standard Specifications, Project Special Provisions, Standard Special Provisions, Permits or Plans that reference is made to “NCDENR” or “North Carolina Department of Environment and Natural Resources”, replace with “NCDEQ” or “North Carolina Department of Environmental Quality” respectively, as the case may be.

PROJECT SPECIAL PROVISIONS

GEOTECHNICAL

| | |
|--|------------------|
| MSE RETAINING WALLS (LRFD) - (5/16/2017) | GT-1.1 - GT-1.12 |
| ROCK EMBANKMENTS PROVISION (SPECIAL) | GT-2.1 - GT-2.1 |
| GEOTEXTILE FOR PAVEMENT STABILIZATION - (1/21/2014) | GT-3.1 - GT-3.2 |
| SEGMENTAL GRAVITY RETAINING WALLS (LRFD) - (5/16/2017) | GT-4.1 - GT-4.5 |
| STANDARD SHORING - (3/17/2015) | GT-5.1 - GT-5.4 |
| PILES (LRFD) - (5/16/2017) | GT-6.1 - GT-6.3 |
| DRILLED PIERS (LRFD) - (5/16/2017) | GT-7.1 - GT-7.2 |

DocuSigned by:
Geotechnical Engineering Unit
E06538624A11498...

4/4/2017

MECHANICALLY STABILIZED EARTH RETAINING WALLS**(5-16-17)****1.0 GENERAL**

Construct mechanically stabilized earth (MSE) retaining walls consisting of steel or geosynthetic reinforcement in the reinforced zone connected to vertical facing elements or end bent caps. Use precast concrete panels for vertical facing elements and coarse aggregate in the reinforced zone unless noted otherwise in the plans. Provide reinforced concrete coping and pile sleeves as required. Design and construct MSE retaining walls based on actual elevations and wall dimensions in accordance with the contract and accepted submittals. Use a prequalified MSE Wall Installer to construct MSE retaining walls.

Define MSE wall terms as follows:

Geosynthetic or Geogrid Reinforcement – Polyester Type (PET), HDPE or Polypropylene (PP) geogrid reinforcement,

Geogrid – PET, HDPE or PP geogrid,

Reinforcement – Steel or geogrid reinforcement,

Aggregate – Coarse or fine aggregate,

Panel – Precast concrete panel,

Coping – Precast or cast-in-place concrete coping,

MSE Wall – Mechanically stabilized earth retaining wall,

MSE Wall Vendor – Vendor supplying the chosen MSE wall system,

MSE Panel Wall – MSE wall with panels,

MSE Segmental Wall – MSE wall with segmental retaining wall (SRW) units and

Abutment Wall – MSE wall with bridge foundations in any portion of the reinforced zone or an MSE wall connected to an abutment wall (Even if bridge foundations only penetrate a small part of the reinforced zone, the entire MSE wall is considered an abutment wall).

Use an approved MSE wall system in accordance with the plans and any NCDOT restrictions or exceptions for the chosen system. Value engineering proposals for other MSE wall systems will not be considered. Do not use MSE wall systems with an “approved for provisional use” status for abutment walls or MSE walls subject to scour, walls with design heights greater than 35 ft or walls supporting or adjacent to railroads or interstate highways. The list of approved MSE wall systems with approval status is available from:

connect.ncdot.gov/resources/Geological/Pages/Products.aspx

2.0 MATERIALS

Refer to the *Standard Specifications*.

| Item | Section |
|-----------------------|----------------|
| Aggregate | 1014 |
| Corrugated Steel Pipe | 1032-3 |
| Epoxy, Type 3A | 1081 |
| Geotextiles, Type 2 | 1056 |
| Grout, Type 3 | 1003 |

| | |
|-----------------------------------|-----------|
| Joint Materials | 1028 |
| Portland Cement Concrete, Class A | 1000 |
| Precast Retaining Wall Coping | 1077 |
| Reinforcing Steel | 1070 |
| Retaining Wall Panels | 1077 |
| Segmental Retaining Wall Units | 1040-4 |
| Select Material, Class V | 1016 |
| Shoulder Drain Materials | 816-2 |
| Steel Pipe | 1036-4(A) |

Use galvanized corrugated steel pipe with a zinc coating weight of 2 oz/sf (G200) for pile sleeves. Provide Type 2 geotextile for filtration and separation geotextiles. Use Class A concrete for cast-in-place coping, leveling concrete and pads. Use galvanized steel pipe, threaded rods and nuts for the PET geogrid reinforcement vertical obstruction detail. Provide galvanized Grade 36 anchor rods and Grade A hex nuts that meet AASHTO M 314 for threaded rods and nuts.

Use panels and SRW units from producers approved by the Department and licensed by the MSE Wall Vendor. Provide steel strip connectors embedded in panels fabricated from structural steel that meets the requirements for steel strip reinforcement. Unless required otherwise in the contract, produce panels with a smooth flat final finish that meets Article 1077-11 of the *Standard Specifications*. Accurately locate and secure reinforcement connectors in panels and maintain required concrete cover. Produce panels within 1/4" of the panel dimensions shown in the accepted submittals.

Damaged panels or SRW units with excessive discoloration, chips or cracks as determined by the Engineer will be rejected. Do not damage reinforcement connection devices or mechanisms in handling or storing panels and SRW units.

Store steel materials on blocking at least 12" above the ground and protect it at all times from damage; and when placing in the work make sure it is free from dirt, dust, loose mill scale, loose rust, paint, oil or other foreign materials. Handle and store geotextiles and geogrids in accordance with Article 1056-2 of the *Standard Specifications*. Load, transport, unload and store MSE wall materials so materials are kept clean and free of damage. Bent, damaged or defective materials will be rejected.

A. Aggregate

Use standard size No. 57, 57M, 67 or 78M that meets Table 1005-1 of the *Standard Specifications* for coarse aggregate except do not use No. 57 or 57M stone in the reinforced zone of MSE walls with geosynthetic reinforcement or connectors. Use the following for fine aggregate:

1. Standard size No. 1S, 2S, 2MS or 4S that meets Table 1005-2 of the *Standard Specifications* or
2. Gradation that meets Class III, Type 3 select material in accordance with Article 1016-3 of the *Standard Specifications*.

Fine aggregate is exempt from mortar strength in Subarticle 1014-1(E) of the *Standard Specifications*. Use fine aggregate with a maximum organic content of 1.0%. Provide aggregate with electrochemical properties that meet the following requirements:

| AGGREGATE pH REQUIREMENTS | | |
|--|--|-----------|
| Aggregate Type (in reinforced zone) | Reinforcement or Connector Material | pH |
| Coarse or Fine | Steel | 5 – 10 |
| Coarse or Fine | PET | 5 – 8 |
| Coarse or Fine | Polyolefin (HDPE or Polypropylene) | 4.5 – 9 |

| AGGREGATE CHEMICAL REQUIREMENTS (Steel Reinforcement/Connector Materials Only) | | | |
|---|-------------------------------------|------------------------|------------------------|
| Aggregate Type (in reinforced zone) | Resistivity | Chlorides | Sulfates |
| Coarse | $\geq 5,000 \Omega \cdot \text{cm}$ | $\leq 100 \text{ ppm}$ | $\leq 200 \text{ ppm}$ |
| Fine | $\geq 3,000 \Omega \cdot \text{cm}$ | | |

Use aggregate from sources participating in the Department's Aggregate QC/QA Program as described in Section 1006 of the *Standard Specifications*. Sample and test aggregate in accordance with the *Mechanically Stabilized Earth Wall Aggregate Sampling and Testing Procedures*. Electrochemical testing is only required for coarse aggregate from sources in the Coastal Plain as defined by Subarticle 1018-2(B)(1).

B. Reinforcement

Provide steel or geosynthetic reinforcement supplied by the MSE Wall Vendor or a manufacturer approved or licensed by the vendor. Use reinforcement approved for the chosen MSE wall system. The list of approved reinforcement for each MSE wall system is available from the website shown elsewhere in this provision.

1. Steel Reinforcement

Provide Type 1 material certifications in accordance with Article 106-3 of the *Standard Specifications* for steel reinforcement. Use welded wire grid reinforcement ("mesh", "mats" and "ladders") that meet Article 1070-3 of the *Standard Specifications* and steel strip reinforcement ("straps") that meet ASTM A572, A1011 or A463. Use 10 gauge or heavier structural steel Grade 50 or higher for steel strip reinforcement. Galvanize steel reinforcement in accordance with Section 1076 of the *Standard Specifications* or provide aluminized steel strip reinforcement that meet ASTM A463, Type 2-100.

2. Geosynthetic Reinforcement

Geogrids will be identified by the product label attached to the original packaging

or the geogrid itself by the Manufacturer. Allow the Engineer to visually verify geogrid products before installation. Geogrids that are unwrapped, missing original packaging or previously opened may not be used unless approved by the Engineer.

Use HDPE or PP geogrid for geogrid reinforcement connected to backwalls of end bent caps. Use PET or HDPE geogrid for geogrid reinforcement connected to SRW units and only HDPE geogrid for geogrid reinforcement connected to panels.

Define “machine direction” (MD) and “cross-machine direction” (CD) for geogrids in accordance with ASTM D4439. Provide Type 1 material certifications in accordance with Article 1056-3 of the *Standard Specifications*.

Provide extruded geogrids manufactured from punched and drawn polypropylene sheets for PP geogrids that meet the following:

| PP GEOGRID REQUIREMENTS | | |
|---|---------------------------------|----------------------|
| Property | Requirement¹ | Test Method |
| Aperture Dimensions ² | 1" x 1.2" | N/A |
| Minimum Rib Thickness ² | 0.07" x 0.07" | N/A |
| Tensile Strength @ 2% Strain ² | 580 lb/ft x 690 lb/ft | ASTM D6637, Method A |
| Tensile Strength @ 5% Strain ² | 1,200 lb/ft x 1,370 lb/ft | |
| Ultimate Tensile Strength ² | 1,850 lb/ft x 2,050 lb/ft | |
| Junction Efficiency ³ (MD) | 93% | ASTM D7737 |
| Flexural Rigidity ⁴ | 2,000,000 mg-cm | ASTM D7748 |
| Aperture Stability Modulus ⁵ | 0.55 lb-ft/degrees | ASTM D7864 |
| UV Stability (Retained Strength) | 100% (after 500 hr of exposure) | ASTM D4355 |

1. MARV per Article 1056-3 of the *Standard Specifications* except dimensions and thickness are nominal.
2. Requirement for MD x CD.
3. Junction Efficiency (%) = (Average Junction Strength (X_{jave}) / Ultimate Tensile Strength (MD) from ASTM D6637, Method A) × 100.
4. Test specimens two ribs wide, with transverse ribs cut flush with exterior edges of longitudinal ribs, and sufficiently long to enable measurement of the overhang dimension.
5. Applied moment of 17.7 lb-inch (torque increment).

C. Bearing Pads

For MSE panel walls, use bearing pads that meet Section 3.6.1.a of the *FHWA Design and Construction of Mechanically Stabilized Earth Walls and Reinforced Soil Slopes – Volume I* (Publication No. FHWA-NHI-10-024) except durometer hardness for rubber pads may be 60 or 80 ± 5 and density testing for HDPE pads may be in accordance with ASTM D1505 or D792. Provide bearing pads with thicknesses that meet the following:

| BEARING PAD THICKNESS | |
|----------------------------------|---|
| Facing Area per Panel (A) | Minimum Pad Thickness After Compression (based on 2 times panel weight above pads) |
| | |

| | |
|--------------------------------|------|
| $A \leq 30$ sf | 1/2" |
| $30 \text{ sf} < A \leq 75$ sf | 3/4" |

D. Miscellaneous Components

Miscellaneous components may include connectors (e.g., anchors, bars, clamps, pins, plates, ties, etc.), fasteners (e.g., bolts, nuts, washers, etc.) and any other MSE wall components not included above. Galvanize steel components in accordance with Section 1076 of the *Standard Specifications*. Provide miscellaneous components approved for the chosen MSE wall system. The list of approved miscellaneous components for each MSE wall system is available from the website shown elsewhere in this provision.

3.0 PRECONSTRUCTION REQUIREMENTS

A. MSE Wall Surveys

The Retaining Wall Plans show a plan view, typical sections, details, notes and an elevation or profile view (wall envelope) for each MSE wall. Before beginning MSE wall design, survey existing ground elevations shown in the plans and other elevations in the vicinity of MSE wall locations as needed. For proposed slopes above or below MSE walls, survey existing ground elevations to at least 10 ft beyond slope stake points. Based on these elevations, finished grades and actual MSE wall dimensions and details, submit revised wall envelopes for acceptance. Use accepted wall envelopes for design.

B. MSE Wall Designs

For MSE wall designs, submit 11 copies of working drawings and 3 copies of design calculations and a PDF copy of each at least 30 days before the preconstruction meeting. Note name and NCDOT ID number of the panel or SRW unit production facility on the working drawings. Do not begin MSE wall construction until a design submittal is accepted.

Use a prequalified MSE Segmental Wall Design Consultant to design MSE segmental walls. Provide MSE segmental wall designs sealed by a Design Engineer approved as a Geotechnical Engineer (key person) for the MSE Segmental Wall Design Consultant. Provide MSE panel wall designs sealed by a Design Engineer licensed in the state of North Carolina and employed or contracted by the MSE Wall Vendor.

Design MSE walls in accordance with the plans, *AASHTO LRFD Bridge Design Specifications* and any NCDOT restrictions for the chosen MSE wall system unless otherwise required. Design MSE walls for seismic if walls are located in seismic zone 2 based on Figure 2-1 of the *Structure Design Manual*. Connect reinforcement to panels or SRW units with methods or devices approved for the chosen system. Use a uniform reinforcement length throughout the wall height of at least 0.7H with H as shown in the plans or 6 ft, whichever is longer, unless noted otherwise in the plans.

Extend the reinforced zone at least 6" beyond end of reinforcement. Do not locate drains, the reinforced zone or leveling pads outside right-of-way or easement limits.

Use the simplified method for determining maximum reinforcement loads and design parameters approved for the chosen MSE wall system or default values in accordance with the AASHTO LRFD specifications. Design steel components including reinforcement and connectors for the design life noted in the plans and aggregate type in the reinforced zone. If an MSE wall system with geogrid reinforcement includes any steel parts for obstructions, bin walls, connections or other components, design steel exposed to aggregate for the design life noted in the plans and aggregate type in the reinforced zone. Use "Loss of galvanizing" metal loss rates for nonaggressive backfill in accordance with the AASHTO LRFD specifications for galvanized and aluminized steel and metal loss rates for carbon steel in accordance with the following:

| CARBON STEEL CORROSION RATES | |
|--|---|
| Aggregate Type (in reinforced zone) | Carbon Steel Loss Rate (after coating depletion) |
| Coarse | 0.47 mil/year |
| Fine (except abutment walls) | 0.58 mil/year |
| Fine (abutment walls) | 0.70 mil/year |

For PET or HDPE geogrid reinforcement and geosynthetic connectors, use approved geosynthetic properties for the design life noted in the plans and aggregate type in the reinforced zone. For PP geogrid reinforcement connected to end bent caps, use the following design parameters for the aggregate type in the reinforced zone.

| PP GEOGRID REINFORCEMENT DESIGN PARAMETERS | | | | |
|---|--------------------------------|-----------|----------|----------|
| Aggregate Type (in reinforced zone) | T_{al} (MD) | F* | α | ρ |
| Coarse | 400 lb/ft | 0.70 | 0.8 | 32.0° |
| Fine | 428 lb/ft | 0.54 | 0.8 | 28.35° |

Where,

- T_{al} = long-term design strength (LTDS),
 F* = pullout resistance factor,
 α = scale effect correction factor and
 ρ = soil-geogrid friction angle.

When noted in the plans, design MSE walls for a live load (traffic) surcharge of 250 lb/sf in accordance with Figure C11.5.6-3(b) of the AASHTO LRFD specifications. For steel beam guardrail with 8 ft posts or concrete barrier rail above MSE walls, analyze top 2 reinforcement layers for traffic impact loads in accordance with Section 7.2 of the FHWA MSE wall manual shown elsewhere in this provision except use the following for geosynthetic reinforcement rupture:

$$\phi T_{al} R_c \geq T_{max} + (T_I / RF_{CR})$$

Where,

| | | |
|-----------|---|--|
| ϕ | = | resistance factor for tensile resistance in accordance with Section 7.2.1 of the FHWA MSE wall manual, |
| T_{al} | = | long-term geosynthetic design strength approved for chosen MSE wall system, |
| R_c | = | reinforcement coverage ratio = 1 for continuous geosynthetic reinforcement, |
| T_{max} | = | factored static load in accordance with Section 7.2 of the FHWA MSE wall manual, |
| T_I | = | factored impact load in accordance with Section 7.2 of the FHWA MSE wall manual and |
| RF_{CR} | = | creep reduction factor approved for chosen MSE wall system. |

When shown in the plans for abutment walls, use pile sleeves to segregate piles from aggregate in the reinforced zone. If existing or future obstructions such as foundations, guardrail, fence or handrail posts, moment slabs, pavements, pipes, inlets or utilities will interfere with reinforcement, maintain a clearance of at least 3" between obstructions and reinforcement unless otherwise approved. Design reinforcement for obstructions and locate reinforcement layers so all of reinforcement length is within 3" of corresponding connection elevations. Modify PET geogrid reinforcement for obstructions as shown in the plans.

Use 6" thick cast-in-place unreinforced concrete leveling pads beneath panels and SRW units that are continuous at steps and extend at least 6" in front of and behind bottom row of panels or SRW units. Unless required otherwise in the plans, embed top of leveling pads in accordance with the following requirements:

| EMBEDMENT REQUIREMENTS | | |
|--|---|---|
| Front Slope¹ (H:V) | Minimum Embedment Depth² (whichever is greater) | |
| 6:1 or flatter (except abutment walls) | H/20 | 1 ft for $H \leq 10$ ft 2 ft for $H > 10$ ft |
| 6:1 or flatter (abutment walls) | H/10 | 2 ft |
| > 6:1 to < 3:1 | H/10 | 2 ft |
| 3:1 to 2:1 | H/7 | 2 ft |

1. Front slope is as shown in the plans.
2. Define "H" as the maximum design height plus embedment per wall with the design height and embedment as shown in the plans.

When noted in the plans, locate a continuous aggregate shoulder drain along the base of the reinforced zone behind the aggregate. Provide wall drainage systems consisting of drains and outlet components in accordance with Standard Drawing No. 816.02 of the *Roadway Standard Drawings*.

For MSE panel walls, cover joints at back of panels with filtration geotextiles at least 12" wide. If the approval of the chosen MSE wall system does not require a minimum number of bearing pads, provide the number of pads in accordance with the following:

| NUMBER OF BEARING PADS | | |
|--------------------------------------|---|--|
| Facing Area per Panel (A) | Maximum Wall Height Above Horizontal Panel Joint | Minimum Number of Pads per Horizontal Panel Joint |
| $A \leq 30$ sf | 25 ft | 2 |
| | 35 ft ¹ | 3 |
| $30 \text{ sf} < A \leq 75$ sf | 25 ft | 3 |
| | 35 ft ¹ | 4 |

1. Additional bearing pads per horizontal panel joint may be required for wall heights above joints greater than 35 ft.

For MSE segmental walls, coarse aggregate is required in any SRW unit core spaces and between and behind SRW units for a horizontal distance of at least 18". Separation geotextiles are required between the aggregate and overlying fill or pavement sections except when concrete pavement, full depth asphalt or cement treated base is placed directly on aggregate. When noted in the plans, separation geotextiles are also required at the back of the reinforced zone between the aggregate and backfill or natural ground. Unless required otherwise in the plans, use reinforced concrete coping at top of walls that meets the following requirements:

1. Coping dimensions as shown in the plans,
2. At the Contractor's option, coping that is precast or cast-in-place concrete for MSE panel walls unless cast-in-place coping is required as shown in the plans,
3. Cast-in-place concrete coping for MSE segmental walls and
4. At the Contractor's option and when shown in the plans, cast-in-place concrete coping that extends down back of panels or SRW units or connects to panels or SRW units with dowels.

For MSE segmental walls with dowels, attach dowels to top courses of SRW units in accordance with the following:

1. Set dowels in core spaces of SRW units filled with grout instead of coarse aggregate or
2. Embed adhesively anchored dowels in holes of solid SRW units with epoxy.

For MSE panel walls with coping, connect cast-in-place concrete coping or leveling concrete for precast concrete coping to top row of panels with dowels cast into panels. When concrete barrier rail is required above MSE walls, use concrete barrier rail with moment slab as shown in the plans.

Submit working drawings and design calculations for acceptance in accordance with Article 105-2 of the *Standard Specifications*. Submit working drawings showing plan views, wall profiles with foundation pressures, typical sections with reinforcement and connection details, aggregate locations and types, geotextile locations and details of

leveling pads, panels or SRW units, coping, bin walls, slip joints, pile sleeves, etc. If necessary, include details on working drawings for concrete barrier rail with moment slab, reinforcement splices if allowed for the chosen MSE wall system, reinforcement connected to end bent caps, curved MSE walls with tight (short) radii and obstructions extending through walls or interfering with reinforcement, leveling pads, barriers or moment slabs. Submit design calculations for each wall section with different surcharge loads, geometry or material parameters. At least one analysis is required for each wall section with different reinforcement lengths. When designing MSE walls with computer software other than MSEW, use MSEW, version 3.0 with update 14.96 or later, manufactured by ADAMA Engineering, Inc. to verify the design. At least one MSEW analysis is required per 100 ft of wall length with at least one analysis for the wall section with the longest reinforcement. Submit electronic MSEW input files and PDF output files with design calculations.

C. Preconstruction Meeting

Before starting MSE wall construction, hold a preconstruction meeting to discuss the construction and inspection of the MSE walls. If this meeting occurs before all MSE wall submittals have been accepted, additional preconstruction meetings may be required before beginning construction of MSE walls without accepted submittals. The Resident or Bridge Maintenance Engineer, Bridge Construction Engineer, Geotechnical Operations Engineer, Contractor and MSE Wall Installer Superintendent will attend preconstruction meetings.

4.0 CORROSION MONITORING

Corrosion monitoring is required for MSE walls with steel reinforcement. The Engineer will determine the number of monitoring locations and where to install the instrumentation. Contact M&T before beginning wall construction. M&T will provide the corrosion monitoring instrumentation kits and if necessary, assistance with installation.

5.0 SITE ASSISTANCE

Unless otherwise approved, an MSE Wall Vendor representative is required to assist and guide the MSE Wall Installer on-site for at least 8 hours when the first panels or SRW units and reinforcement layer are placed. If problems are encountered during construction, the Engineer may require the vendor representative to return to the site for a time period determined by the Engineer.

6.0 CONSTRUCTION METHODS

Control drainage during construction in the vicinity of MSE walls. Direct run off away from MSE walls, aggregate and backfill. Contain and maintain aggregate and backfill and protect material from erosion.

Excavate as necessary for MSE walls in accordance with the accepted submittals. If applicable and at the Contractor's option, use temporary shoring for wall construction instead of temporary slopes to construct MSE walls. Define "temporary shoring for wall

construction” as temporary shoring not shown in the plans or required by the Engineer including shoring for OSHA reasons or the Contractor’s convenience.

Unless required otherwise in the plans, install foundations and if required, pile sleeves located in the reinforced zone before placing aggregate or reinforcement. Brace piles in the reinforced zone to maintain alignment when placing and compacting aggregate. Secure piles together with steel members near top of piles. Clamp members to piles instead of welding if bracing is at or below pile cut-off elevations.

Notify the Engineer when foundation excavation is complete. Do not place leveling pad concrete, aggregate or reinforcement until excavation dimensions and foundation material are approved.

Construct cast-in-place concrete leveling pads at elevations and with dimensions shown in the accepted submittals and in accordance with Section 420 of the *Standard Specifications*. Cure leveling pads at least 24 hours before placing panels or SRW units.

Erect and support panels and stack SRW units so the final wall position is as shown in the accepted submittals. Stagger SRW units to create a running bond by centering SRW units over joints in the row below as shown in the accepted submittals. Space bearing pads in horizontal panel joints as shown in the accepted submittals and cover all panel joints with filtration geotextiles as shown in the accepted submittals. Attach filtration geotextiles to back of panels with adhesives, tapes or other approved methods.

Construct MSE walls with the following tolerances:

- A. SRW units are level from front to back and between units when checked with a 4 ft long level,
- B. Vertical joint widths are 1/4" maximum for SRW units and 3/4", $\pm 1/4$ " for panels,
- C. Final wall face is within 3/4" of horizontal and vertical alignment shown in the accepted submittals when measured along a 10 ft straightedge and
- D. Final wall plumbness (batter) is not negative (wall face leaning forward) and within 0.5° of vertical unless otherwise approved.

Place reinforcement at locations and elevations shown in the accepted submittals and within 3" of corresponding connection elevations. Install reinforcement with the direction shown in the accepted submittals. Pull geogrid reinforcement taut so that it is in tension and free of kinks, folds, wrinkles or creases. Reinforcement may be spliced once per reinforcement length if shown in the accepted submittals. Use reinforcement pieces at least 6 ft long. Contact the Engineer when unanticipated existing or future obstructions such as foundations, guardrail, fence or handrail posts, pavements, pipes, inlets or utilities will interfere with reinforcement. To avoid obstructions, deflect, skew or modify reinforcement as shown in the accepted submittals.

Place aggregate in the reinforced zone in 8" to 10" thick lifts. Compact fine aggregate in accordance with Subarticle 235-3(C) of the *Standard Specifications*. Use only hand operated compaction equipment to compact aggregate within 3 ft of panels or SRW units.

At a distance greater than 3 ft, compact aggregate with at least 4 passes of an 8 ton to 10 ton vibratory roller in a direction parallel to the wall face. Smooth wheeled or rubber tired rollers are also acceptable for compacting aggregate. Do not use sheepsfoot, grid rollers or other types of compaction equipment with feet. Do not displace or damage reinforcement when placing and compacting aggregate. End dumping directly on geogrids is not permitted. Do not operate heavy equipment on reinforcement until it is covered with at least 8" of aggregate. Replace any damaged reinforcement to the satisfaction of the Engineer.

Backfill for MSE walls outside the reinforced zone in accordance with Article 410-8 of the *Standard Specifications*. If a drain is required, install wall drainage systems as shown in the accepted submittals and in accordance with Section 816 of the *Standard Specifications*. If pile sleeves are required, fill sleeves with loose uncompacted sand before constructing end bent caps.

Install dowels as necessary for SRW units and place and construct coping and leveling concrete as shown in the accepted submittals. Construct leveling concrete in accordance with Section 420 of the *Standard Specifications*. Construct cast-in-place concrete coping in accordance with Subarticle 452-3(C) of the *Standard Specifications*. When single faced precast concrete barrier is required in front of and against MSE walls, stop coping just above barrier so coping does not interfere with placing barrier up against wall faces. If the gap between a single faced barrier and wall face is wider than 2", fill gap with Class V select material (standard size No. 78M stone). Otherwise, fill gap with backer rod and seal joint between barrier and MSE wall with silicone sealant.

Install reinforcement connected to end bent caps in accordance with the accepted submittals and embed geogrid reinforcement in end bent caps as shown in the plans. After cutting geogrid reinforcement to required lengths, reroll and rewrap portions of geogrids not embedded in caps to protect geogrids from damage. When separation geotextiles are required, overlap adjacent geotextiles at least 18" and hold separation geotextiles in place with wire staples or anchor pins as needed. Seal joints above and behind MSE walls between coping and concrete slope protection with silicone sealant.

7.0 MEASUREMENT AND PAYMENT

MSE Retaining Wall No. __ will be measured and paid in square feet. MSE walls will be measured as the square feet of wall face area with the pay height equal to the difference between top of wall and top of leveling pad elevations. Define "top of wall" as top of coping or top of panels or SRW units for MSE walls without coping.

The contract unit price for *MSE Retaining Wall No. __* will be full compensation for providing designs, submittals, labor, tools, equipment and MSE wall materials, excavating, backfilling, hauling and removing excavated materials and supplying site assistance, leveling pads, panels, SRW units, reinforcement, aggregate, wall drainage systems, geotextiles, bearing pads, coping, miscellaneous components and any incidentals necessary to construct MSE walls. The contract unit price for *MSE Retaining Wall No. __* will also be full compensation for reinforcement connected to and aggregate behind end bent caps in

the reinforced zone, wall modifications for obstructions, pile sleeves filled with sand, joints sealed with silicone sealant and gaps between barriers and MSE walls filled with backer rod or No. 78M stone, if required.

No separate payment will be made for temporary shoring for wall construction. Temporary shoring for wall construction will be incidental to the contract unit price for *MSE Retaining Wall No. __*.

The contract unit price for *MSE Retaining Wall No. __* does not include the cost for ditches, fences, handrails, barrier or guardrail associated with MSE walls as these items will be paid for elsewhere in the contract.

Where it is necessary to provide backfill material behind the reinforced zone from sources other than excavated areas or borrow sources used in connection with other work in the contract, payment for furnishing and hauling such backfill material will be paid as extra work in accordance with Article 104-7 of the *Standard Specifications*. Placing and compacting such backfill material is not considered extra work but is incidental to the work being performed.

Payment will be made under:

Pay Item
MSE Retaining Wall No. __

Pay Unit
Square Foot



DocuSigned by:
Scott A. Hidden
F760CAEB96FC4D3...

2/2/2017

ROCK EMBANKMENTS:

(SPECIAL)

Description

Construct rock embankments in accordance with the contract. Rock embankments are required to construct embankments in water at locations shown in the plans and as directed.

Materials

Refer to Division 10 of the *Standard Specifications*.

| Item | Section |
|---|----------------|
| Geotextile for Rock Embankments, Type 2 | 1056 |
| Rip Rap Materials | 1042 |
| Select Material | 1016 |

Provide Type 2 geotextile for filtration geotextiles. Use Class VII select material for rock embankments. Use Class B rip rap and Class VI select material (standard size No. 57) as filler material over Class VII.

Construction Methods

Construct rock embankments in accordance with the slopes, dimensions and elevations shown in the plans and Section 235 of the *Standard Specifications*. Place Class VII so smaller rocks are uniformly distributed throughout rock embankments. Provide a uniform surface free of obstructions, debris and groups of large rocks that could cause voids in embankments.

Place Class B rip rap over rock embankments to fill any large voids. Place and compact No. 57 stone over the Class B rip rap and rock embankments to fill remaining voids and protect filtration geotextiles against damage. Install filtration geotextiles on top of filler material in accordance with Article 270-3 of the *Standard Specifications* before placing embankment fill material.

Measurement and Payment

Rock Embankments consist of Class VII select material, Class B Rip Rap and Class VI select material (#57 Stone). *Rock Embankments* will be measured and paid in tons. Measure rip rap and select material by weighing material in trucks in accordance with Article 106-7 of the *Standard Specifications*. The contract unit prices for *Rock Embankment* will be full compensation for providing, hauling, handling, placing, compacting and maintaining material.

Geotextile for Rock Embankments will be measured and paid in square yards. Geotextiles will be measured along the top of the #57 stone layer as the square yards of exposed geotextiles before placing embankment fill. No measurement will be made for overlapping geotextiles. The contract unit price for *Geotextile for Rock Embankments* will be full compensation for providing, transporting and placing geotextiles.

Payment will be made under:

| Pay Item | Pay Unit |
|---------------------------------|-----------------|
| Rock Embankments | Ton |
| Geotextile for Rock Embankments | Square Yard |



DS
sll

GEOTEXTILE FOR PAVEMENT STABILIZATION:**(1-21-14)****Description**

Furnish and place geotextile for pavement stabilization in accordance with the contract. Geotextile for pavement stabilization may be required to prevent pavement cracking and provide separation between the subgrade and pavement section at locations shown in the plans and as directed.

Materials

Refer to Division 10 of the *Standard Specifications*.

Item

Geotextiles

Section

1056

Provide Type 5 geotextile for geotextile for pavement stabilization that meets the following requirements:

| GEOTEXTILE FOR PAVEMENT STABILIZATION REQUIREMENTS | | |
|---|---------------------------------------|--------------------|
| Property | Requirement (MARV^A) | Test Method |
| Tensile Strength @ 5% Strain (MD & CD ^A) | 1,900 lb/ft | ASTM D4595 |
| Ultimate Tensile Strength (MD & CD ^A) | 4,800 lb/ft | ASTM D4595 |
| Melting Point | 300° F | ASTM D276 |

A. Define “minimum average roll value” (MARV), “machine direction” (MD) and “cross-machine direction” (CD) in accordance with ASTM D4439.

Construction Methods

Notify the Engineer when the roadbed is completed within 2" of subgrade elevation. The Engineer will sample and test subgrade soils for quality to determine if geotextile for pavement stabilization is required at locations shown in the plans and other locations as directed. For subgrades without stabilization, allow 24 days to determine if geotextile for pavement stabilization is required. For stabilized subgrades with geotextile for pavement stabilization, stabilize subgrade soils to 12" beyond the base course as shown in the plans.

Place geotextile for pavement stabilization on subgrades immediately below pavement sections as shown in the plans and in slight tension free of kinks, folds, wrinkles or creases. Install geotextiles with the MD perpendicular to the roadway centerline. The MD is the direction of the length or long dimension of the geotextile roll. Do not splice or overlap geotextiles in the MD so splices or overlaps are parallel to the roadway centerline. Extend geotextile for pavement stabilization 12" beyond the base course as shown in the plans.

Completely cover subgrades with geotextile for pavement stabilization so geotextiles are adjacent to each other in the CD, i.e., perpendicular to the MD. The CD is the direction of the width or short dimension of the geotextile roll. Overlapping geotextiles in the CD is permitted but not required. Overlap geotextiles in the direction that base course will be placed to prevent lifting the edge of the top geotextile.

For asphalt base courses, asphalt mixture temperatures in the truck may not exceed 315° F at the time of placement. Do not damage geotextile for pavement stabilization when constructing base

courses. Place and compact base courses in accordance with the *Standard Specifications*. Do not operate heavy equipment on geotextiles any more than necessary to construct pavement sections. Replace any damaged geotextiles to the satisfaction of the Engineer.

Measurement and Payment

Geotextile for Pavement Stabilization will be measured and paid in square yards. Geotextiles will be measured along subgrades as the square yards of exposed geotextiles before placing base courses. No measurement will be made for overlapping geotextiles. The contract unit price for *Geotextile for Pavement Stabilization* will be full compensation for providing, transporting and placing geotextiles.

Payment will be made under:

Pay Item

Geotextile for Pavement Stabilization

Pay Unit

Square Yard



DocuSigned by:
Scott A. Hidden
F760CAEB96FC4D3...

2/2/2017

SEGMENTAL GRAVITY RETAINING WALLS**(5-16-17)****1.0 GENERAL**

Construct segmental gravity retaining walls consisting of segmental retaining wall (SRW) units supported by aggregate footings. Provide cast-in-place concrete slope protection as required. If the plans do not include Standard Detail No. 453.02 or 453.03, design and construct segmental gravity retaining walls based on actual elevations, wall dimensions and batter in accordance with the contract and accepted submittals. Otherwise, construct segmental gravity retaining walls based on actual elevations, wall dimensions and batter in accordance with the contract, accepted submittals and Standard Detail No. 453.02 or 453.03.

Define "block wall" as a segmental gravity retaining wall and "standard block wall" as a block wall that meets a standard segmental gravity retaining wall drawing (Standard Detail No. 453.02 or 453.03). Define "blocks" as SRW units, "cap blocks" as SRW cap units and "Block Vendor" as the vendor licensing the block producer. Define "slope protection" as cast-in-place concrete slope protection.

2.0 MATERIALS

Refer to the *Standard Specifications*.

| Item | Section |
|-----------------------------------|----------------|
| Geotextiles, Type 2 | 1056 |
| Joint Materials | 1028 |
| Portland Cement Concrete, Class B | 1000 |
| Segmental Retaining Wall Units | 1040-4 |
| Select Material | 1016 |
| Subsurface Drainage Materials | 815-2 |

Provide Type 2 geotextile for separation geotextiles. Use Class VI select material for No. 57 stone and Class B concrete for slope protection. Provide PVC pipes, fittings, outlet pipes and concrete pads for subsurface drainage materials. For PVC pipes behind block walls, use pipes with perforations that meet AASHTO M 278.

Provide cap blocks that meet the material requirements for blocks. Use blocks from producers approved by the Department and licensed by the Block Vendor. Notify the Engineer of the name and NCDOT ID number of the SRW unit production facility before beginning block production. Unless required otherwise in the plans, provide blocks with a depth (front to back) of at least 12" and cap blocks with a depth of at least 8".

Use approved SRW units for standard block walls. Blocks for standard block walls are approved for either 2 ft or 4 ft maximum design heights with the design height as shown in Standard Detail No. 453.02 or 453.03. The list of approved SRW units with maximum design heights is available from:

connect.ncdot.gov/resources/Geological/Pages/Products.aspx

Do not mix blocks from different Block Vendors on the same block wall. Damaged blocks with excessive discoloration, chips or cracks as determined by the Engineer will be rejected.

Provide adhesives recommended by the Block Vendor. Store adhesives in accordance with the manufacturer's instructions. Load, transport, unload and store block wall materials so materials are kept clean and free of damage.

3.0 PRECONSTRUCTION REQUIREMENTS

A. Block Wall Surveys

The plans typically show a plan view, typical sections, details, notes and an elevation or profile view (wall envelope) for each block wall. Before beginning block wall design or construction, survey existing ground elevations along wall face locations and other elevations in the vicinity of block wall locations as needed. For proposed slopes above or below block walls, survey existing ground elevations to at least 10 ft beyond slope stake points. Based on these elevations, finished grades and actual block wall dimensions, details and batter, submit wall envelopes for acceptance. Use accepted wall envelopes for design, if required, and construction.

B. Block Wall Designs

If the plans do not include Standard Detail No. 453.02 or 453.03, submit 11 copies of working drawings and 3 copies of design calculations and a PDF copy of each for block wall designs at least 30 days before starting block wall construction. Do not begin block wall construction until a design submittal is accepted.

Design block walls in accordance with the plans and Article 11.11 of the *AASHTO LRFD Bridge Design Specifications* unless otherwise required. Neglect material above top of footing for stability computations. Design block walls for the wall batter required by the Block Vendor and clearances shown in the plans. Do not locate blocks or footings outside right-of-way or easement limits.

Use No. 57 stone for aggregate footings beneath blocks. Use 10" thick footings that are continuous at steps and extend at least 6" in front of and at least 9" behind bottom row of blocks. Unless required otherwise in the plans, embed bottom of footings at least 18" below bottom of walls shown in the plans. When noted in the plans, locate a 4" diameter continuous perforated PVC drain pipe in the No. 57 stone in back of footings.

Fill block core spaces with No. 57 stone and between and behind blocks with No. 57 stone for a horizontal distance of at least 12" so stone is continuous in all directions. Assume a unit weight of 100 lb/cf for No. 57 stone. Separation geotextiles are required between No. 57 stone and backfill or natural ground and between stone and overlying fill or pavement section except when concrete pavement, full depth asphalt or cement treated base is placed directly on stone.

Use cap blocks at top of walls. Step top of walls as shown in the plans and double

stack cap blocks at steps so cap blocks are continuous at steps. Extend top of walls 4" to 12" above where finished grade intersects back of blocks or cap blocks. When single faced precast concrete barrier is required in front of and against block walls, fill voids between barrier and wall faces with Class V select material.

Submit working drawings and design calculations for acceptance in accordance with Article 105-2 of the *Standard Specifications*. Submit working drawings showing plan views, wall profiles with required resistances, typical sections, No. 57 stone and geotextile locations and details of footings, blocks, cap blocks, etc. If necessary, include details on working drawings for slope protection and obstructions extending through walls or interfering with footings. Submit design calculations for each wall section with different geometry or material parameters. When designing block walls with computer software, a hand calculation is required for the tallest wall section. Provide block wall designs sealed by an engineer licensed in the state of North Carolina.

4.0 CONSTRUCTION METHODS

Control drainage during construction in the vicinity of block walls. Direct run off away from block walls, No. 57 stone and backfill. Contain and maintain stone and backfill and protect material from erosion.

Excavate as necessary for block walls in accordance with the plans and accepted submittals. Notify the Engineer when foundation excavation is complete. Do not place No. 57 stone for footings until excavation dimensions and foundation material are approved.

Construct aggregate footings at elevations and with dimensions shown in the plans and accepted submittals. If a drain is required, install wall drainage systems consisting of drains and outlet components as shown in the plans and accepted submittals and in accordance with Section 815 of the *Standard Specifications*. Compact No. 57 stone for footings with a vibratory compactor to the satisfaction of the Engineer.

Stack blocks with no negative wall batter (wall face leaning forward) so the final wall position is as shown in the plans and accepted submittals. Place blocks with a maximum vertical joint width of 3/8". Stagger blocks to create a running bond by centering blocks over joints in the row below as shown in the plans and accepted submittals. Construct block walls with the following tolerances:

- A. Blocks are level from front to back and between blocks when checked with a 4 ft long level,
- B. Final wall face is within 2" of horizontal and vertical alignment shown in the plans and accepted submittals, and
- C. Wall batter is within 2° of batter required by the Block Vendor.

Overlap adjacent separation geotextiles at least 18" at seams and hold geotextiles in place

with wire staples or anchor pins as needed. Place No. 57 stone between and behind blocks in 8" to 10" thick lifts. Compact stone with hand operated compaction equipment to the satisfaction of the Engineer. Backfill for block walls behind No. 57 stone in accordance with Article 410-8 of the *Standard Specifications*.

Set cap blocks with a 1/2" to 1-1/2" overhang as shown in the plans and accepted submittals. Place cap blocks using adhesive in accordance with the manufacturer's instructions. Do not place cap blocks if surfaces caps will be attached to are wet or frozen or the air temperature measured at the wall location in the shade away from artificial heat is below 40°F. Before applying adhesive, clean surfaces cap blocks will adhere to and ensure surfaces are dry and free of oil, grease, dust and debris.

Pave slopes above and behind block walls with slope protection as shown in the plans and accepted submittals and in accordance with Article 462-3 of the *Standard Specifications*. Construct slope protection joints at a spacing of 10 ft. Make 1/2" thick expansion joints that meet Article 420-10 of the *Standard Specifications* for every third joint and 1/2" deep grooved contraction joints that meet Subarticle 825-10(B) for the remaining joints.

5.0 MEASUREMENT AND PAYMENT

Segmental Gravity Retaining Walls will be measured and paid in square feet. Block walls will be measured as the square feet of wall face area with the pay height equal to the difference between top of wall and top of footing elevations. Define "top of wall" as top of cap blocks.

The contract unit price for *Segmental Gravity Retaining Walls* will be full compensation for providing designs, if required, submittals, labor, tools, equipment and block wall materials, excavating, backfilling, hauling and removing excavated materials and supplying footings, blocks, select material, wall drainage systems, geotextiles, cap blocks, slope protection and any incidentals necessary to construct block walls.

The contract unit price for *Segmental Gravity Retaining Walls* does not include the cost for ditches, fences, handrails, barrier or guardrail associated with block walls as these items will be paid for elsewhere in the contract.

Where it is necessary to provide backfill material behind No. 57 stone from sources other than excavated areas or borrow sources used in connection with other work in the contract, payment for furnishing and hauling such backfill material will be paid as extra work in accordance with Article 104-7 of the *Standard Specifications*. Placing and compacting such backfill material is not considered extra work but is incidental to the work being performed.

Payment will be made under:

Pay Item
Segmental Gravity Retaining Walls

Pay Unit
Square Foot



DocuSigned by:
Scott A. Hidden
F760CAEB96FC4D3...

2/2/2017

STANDARD SHORING:**(3-17-15)****Description**

Standard shoring includes standard temporary shoring and standard temporary mechanically stabilized earth (MSE) walls. At the Contractor's option, use standard shoring as noted in the plans or as directed. When using standard shoring, a temporary shoring design submittal is not required. Construct standard shoring based on actual elevations and shoring dimensions in accordance with the contract and Standard Detail No. 1801.01 or 1801.02.

Define "standard temporary shoring" as cantilever shoring that meets the standard temporary shoring detail (Standard Detail No. 1801.01). Define "standard temporary wall" as a temporary MSE wall with geotextile or geogrid reinforcement that meets the standard temporary wall detail (Standard Detail No. 1801.02). Define "standard temporary geotextile wall" as a standard temporary wall with geotextile reinforcement and "standard temporary geogrid wall" as a standard temporary wall with geogrid reinforcement. Define "geosynthetics" as geotextiles or geogrids.

Provide positive protection for standard shoring at locations shown in the plans and as directed. See *Temporary Shoring* provision for positive protection types and definitions.

Materials

Refer to the *Standard Specifications*.

| Item | Section |
|--------------------------------|----------------|
| Anchor Pins | 1056-2 |
| Concrete Barrier Materials | 1170-2 |
| Flowable Fill, Excavatable | 1000-6 |
| Geotextiles | 1056 |
| Grout, Type 1 | 1003 |
| Portland Cement Concrete | 1000 |
| Select Material | 1016 |
| Steel Beam Guardrail Materials | 862-2 |
| Steel Sheet Piles and H-Piles | 1084 |
| Untreated Timber | 1082-2 |
| Welded Wire Reinforcement | 1070-3 |
| Wire Staples | 1060-8(D) |

Provide Type 6 material certifications for shoring materials. Use Class IV select material (standard size No. ABC) for temporary guardrail. Use Class A concrete that meets Article 450-2 of the *Standard Specifications* or grout for drilled-in piles.

Based on actual shoring height, positive protection, groundwater elevation, slope or surcharge case and traffic impact at each standard temporary shoring location, use sheet piles with the minimum required section modulus or H-piles with the sizes shown in Standard Detail No. 1801.01. Use untreated timber with a thickness of at least 3" and a bending stress of at least 1,000 psi for timber lagging.

(A) Shoring Backfill

Use Class II, Type 1, Class III, Class V or Class VI select material or material that meets

AASHTO M 145 for soil classification A-2-4 with a maximum PI of 6 for shoring backfill except do not use the following:

- (1) A-2-4 soil for backfill around culverts,
- (2) A-2-4 soil in the reinforced zone of standard temporary walls with a back slope and
- (3) Class VI select material in the reinforced zone of standard temporary geotextile walls.

(B) Standard Temporary Walls

Use welded wire reinforcement for welded wire facing, struts and wires with the dimensions and minimum wire sizes shown in Standard Detail No. 1801.02. Provide Type 2 geotextile for separation and retention geotextiles. Define “machine direction” (MD) and “cross-machine direction” (CD) for geosynthetics in accordance with ASTM D4439. Do not use more than 4 different reinforcement strengths for each standard temporary wall.

(1) Geotextile Reinforcement

Provide Type 5 geotextile for geotextile reinforcement with a mass per unit area of at least 8 oz/sy in accordance with ASTM D5261. Based on actual wall height, groundwater elevation, slope or surcharge case and shoring backfill to be used in the reinforced zone at each standard temporary geotextile wall location, provide geotextiles with ultimate tensile strengths as shown in Standard Detail No. 1801.02.

(2) Geogrid Reinforcement

Handle and store geogrids in accordance with Article 1056-2 of the *Standard Specifications*. Use geogrids with a roll width of at least 4 ft and an “approved” or “approved for provisional use” status code. The list of approved geogrids is available from:

connect.ncdot.gov/resources/Materials/Pages/SoilsLaboratory.aspx

Based on actual wall height, groundwater elevation, slope or surcharge case and shoring backfill to be used in the reinforced zone at each standard temporary geogrid wall location, provide geogrids for geogrid reinforcement with short-term design strengths as shown in Standard Detail No. 1801.02. Geogrids are typically approved for ultimate tensile strengths in the MD and CD or short-term design strengths for a 3-year design life in the MD based on material type. Define material type from the website above for shoring backfill as follows:

| Material Type | Shoring Backfill |
|----------------------|---|
| Borrow | A-2-4 Soil |
| Fine Aggregate | Class II, Type 1 or Class III Select Material |
| Coarse Aggregate | Class V or VI Select Material |

If the website does not list a short-term design strength for an approved geogrid, use a short-term design strength equal to the ultimate tensile strength divided by

3.5 for the geogrid reinforcement.

Preconstruction Requirements

(A) Concrete Barrier

Define “clear distance” behind concrete barrier as the horizontal distance between the barrier and edge of pavement. The minimum required clear distance for concrete barrier is shown in the plans. At the Contractor’s option or if the minimum required clear distance is not available, set concrete barrier next to and up against traffic side of standard shoring except for barrier above standard temporary walls. Concrete barrier with the minimum required clear distance is required above standard temporary walls.

(B) Temporary Guardrail

Define “clear distance” behind temporary guardrail as the horizontal distance between guardrail posts and standard shoring. At the Contractor’s option or if clear distance for standard temporary shoring is less than 4 ft, attach guardrail to traffic side of shoring as shown in the plans. Place ABC in clear distance and around guardrail posts instead of pavement. Do not use temporary guardrail above standard temporary walls.

(C) Standard Shoring Selection Forms

Before beginning standard shoring construction, survey existing ground elevations in the vicinity of standard shoring locations to determine actual shoring or wall heights (H). Submit a standard shoring selection form for each location at least 7 days before starting standard shoring construction. Standard shoring selection forms are available from: connect.ncdot.gov/resources/Geological/Pages/Geotech_Forms_Details.aspx

(D) Preconstruction Meeting

The Engineer may require a shoring preconstruction meeting to discuss the construction and inspection of the standard shoring. If required, schedule this meeting after all standard shoring selection forms have been submitted. The Resident, District or Bridge Maintenance Engineer, Bridge or Roadway Construction Engineer, Geotechnical Operations Engineer, Contractor and Shoring Contractor Superintendent will attend this preconstruction meeting.

Construction Methods

Construct standard shoring in accordance with the *Temporary Shoring* provision.

(A) Standard Temporary Shoring Installation

Based on actual shoring height, positive protection, groundwater elevation, slope or surcharge case and traffic impact at each standard temporary shoring location, install piles with the minimum required embedment and extension for each shoring section in accordance with Standard Detail No. 1801.01. For concrete barrier above and next to standard temporary shoring and temporary guardrail above and attached to standard temporary shoring, use “surcharge case with traffic impact” in accordance with Standard Detail No. 1801.01. Otherwise, use “slope or surcharge case with no traffic impact” in accordance with Standard Detail No. 1801.01. If refusal is reached before driven piles attain the minimum required embedment, use drilled-in H-piles with timber lagging for standard temporary shoring.

(B) Standard Temporary Walls Installation

Based on actual wall height, groundwater elevation, slope or surcharge case, geotextile or geogrid reinforcement and shoring backfill in the reinforced zone at each standard temporary wall location, construct walls with the minimum required reinforcement length and number of reinforcement layers for each wall section in accordance with Standard Detail No. 1801.02. For standard temporary walls with pile foundations in the reinforced zone, drive piles through reinforcement after constructing temporary walls.

For standard temporary walls with interior angles less than 90°, wrap geosynthetics at acute corners as directed by the Engineer. Place geosynthetics as shown in Standard Detail No. 1801.02. Place separation geotextiles between shoring backfill and backfill, natural ground or culverts along the sides of the reinforced zone perpendicular to the wall face. For Class V or VI select material in the reinforced zone, place separation geotextiles between shoring backfill and backfill or natural ground on top of and at the back of the reinforced zone.

Measurement and Payment

Standard shoring will be measured and paid in accordance with the *Temporary Shoring* provision.



DocuSigned by:
Scott A. Hidden
F760CAEB96FC4D3...

2/2/2017

PILES**(5-16-17)**

Revise the *2012 Standard Specifications* as follows:

Page 4-70, Article 450-2, Materials, line 2, in the materials table, replace “Neat Cement Grout, Nonshrink” with “Neat Cement Grout, Type 1”.

Page 4-70, Article 450-2, Materials, line 8, in the last sentence of the second paragraph, replace “approved by the Materials and Tests Unit.” with “that are on the NCDOT Approved Products List.”

Page 4-71, Subarticle 450-3(D), Driven Piles, line 10, add the following after the first sentence of the third paragraph.

Use AASHTO driving stress limits for severe corrosive environments when calcium nitrite corrosion inhibitor is required for prestressed concrete piles.

Page 4-72, Subarticle 450-3(D)(3), Required Driving Resistance, lines 26-30, replace first paragraph with the following:

The Engineer will determine if the proposed pile driving methods and equipment are acceptable and provide the blows/ft and equivalent set for the required driving resistance noted in the plans, i.e., “pile driving criteria” except for structures with pile driving analyzer (PDA) testing. For structures with PDA testing, provide pile driving criteria for any bents and end bents with piles in accordance with Subarticle 450-3(F)(4).

Page 4-73, Subarticle 450-3(E)(1), Pile Excavation, lines 19-20, in the third sentence of the second paragraph, replace “use smooth or corrugated clean watertight steel casings” with “use smooth non-corrugated clean watertight steel casings”.

Page 4-73, Subarticle 450-3(F), Pile Driving Analyzer, lines 45-48, replace third paragraph with the following:

The Engineer will complete the review of the proposed pile driving methods and equipment within 7 days of receiving PDA reports and pile driving criteria. Do not place concrete for caps or footings on piles until PDA reports and pile driving criteria have been accepted.

Page 4-75, Subarticle 450-3(F), Pile Driving Analyzer, line 21, add the following to the end of Article 450-3:

(4) Pile Driving Criteria

Analyze pile driving with the GRL Wave Equation Analysis Program (GRLWEAP) manufactured by Pile Dynamics, Inc. Use the same PDA Consultant that provides PDA reports to perform GRLWEAP analyses and develop pile driving criteria. Provide driving criteria sealed by an engineer approved as a Project Engineer (key person) for the

same PDA Consultant.

Analyze pile driving so driving stresses, energy transfer, ram stroke and blows/ft from PDA testing and resistances from CAPWAP analyses correlate to GRLWEAP models. Provide pile driving criteria for each combination of required driving resistance and pile length installed for all pile types and sizes. Submit 2 copies of pile driving criteria with PDA reports. Include the following for driving criteria:

- (a) Project information in accordance with Subarticle 450-3(F)(3)(a)
- (b) Table showing blows/ft and equivalent set vs. either stroke for multiple strokes in increments of 6" or bounce chamber pressure for multiple pressures in increments of 1 psi
- (c) Maximum stroke or blows/ft or pile cushion requirements to prevent overstressing piles as needed
- (d) GRLWEAP software version information
- (e) PDF copy of all pile driving criteria and executable GRLWEAP input and output files

Page 4-75, Article 450-4, Measurement and Payment, line 24, add the following after the first paragraph:

Pile Driving Equipment Setup for ____ Prestressed Concrete Piles, Pile Driving Equipment Setup for ____ Steel Piles and Pile Driving Equipment Setup for ____ Galvanized Steel Piles will be measured and paid in units of each. Setting up equipment to drive piles will be measured as one per pile. No payment will be made for pile driving equipment setup for installed piles that are not driven. The contract unit price for *Pile Driving Equipment Setup for ____ Prestressed Concrete Piles, Pile Driving Equipment Setup for ____ Steel Piles and Pile Driving Equipment Setup for ____ Galvanized Steel Piles* will be full compensation for mobilizing and demobilizing pile driving equipment, personnel, supplies and incidentals, setting up and breaking down pile driving equipment, e.g., pile hammer, crane, template, etc. and submitting the proposed pile driving methods and equipment.

Page 4-75, Article 450-4, Measurement and Payment, line 31, in the fifth sentence of the second paragraph, replace "driving piles" with "furnishing and installing piles except for the items paid for separately in this article"

Page 4-76, Article 450-4, Measurement and Payment, lines 27-29, replace third sentence of the sixth paragraph with the following:

The contract unit price for *PDA Testing* will be full compensation for performing PDA testing the first time a pile is tested, performing CAPWAP analysis on data collected during initial drive, restrikes and redrives, providing PDA reports, performing GRLWEAP analysis and developing and providing pile driving criteria.

Page 4-76, Article 450-4, Measurement and Payment, line 33, add the following after the list headings:

Pay Item

Pile Driving Equipment Setup for ____ Prestressed Concrete Piles
Pile Driving Equipment Setup for ____ Steel Piles
Pile Driving Equipment Setup for ____ Galvanized Steel Piles

Pay Unit

Each
Each
Each

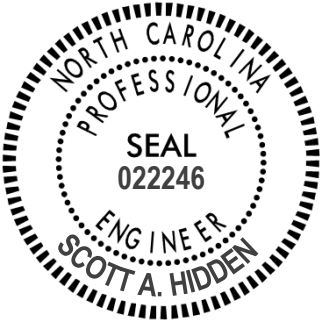

DocuSigned by:
Scott A. Hidden
F760CAEB96FC4D3...

4/4/2017

DRILLED PIERS**(5-16-17)**

Revise the *2012 Standard Specifications* as follows:

Page 4-9, Article 411-1, Description, line 12, replace second sentence in the second paragraph with the following:

Define “permanent casing” as a casing that remains in the excavation and acts as a form for Drilled Pier concrete and “temporary casing” as any casing that is not permanent. Define “rock” as a continuous intact natural material with a standard penetration resistance of 0.1 ft or less per 60 blows or a rock auger penetration rate of less than 2” per 5 minutes of drilling at full crowd force or as determined by the Engineer when rock is not encountered as expected based on these criteria.

Page 4-9, Article 411-2, Materials, line 18, in materials table, replace “Grout, Nonshrink” with “Grout, Type 2”.

Page 4-9, Subarticle 411-2(A), Steel Casing, line 26, add the following after first sentence in the first paragraph:

If permanent casing is required for an excavation, the largest diameter casing in the hole is the permanent casing. This does not apply to working casings around permanent casings as approved by the Engineer.

Page 4-10, Subarticle 411-2(B)(2), Polymer Slurry, line 15 and **Page 4-11, Table 411-3**, replace with the following:

(2) Polymer Slurry

Use polymer slurry products qualified by the Department. Provide polymer slurry with density, viscosity, sand content and pH properties that meet the product requirements. The polymer slurry QPL with the property requirements for each qualified polymer slurry product is available from the Geotechnical Engineering Unit’s website.

Page 4-12, Subarticle 411-3(B), Preconstruction Meeting, line 22, replace with the following:

(A) Preconstruction Meeting

Before starting drilled pier construction, hold a preconstruction meeting to discuss the installation, monitoring and inspection of the drilled piers. Schedule this meeting after the Drilled Pier Contractor mobilizes to the site. If this meeting occurs before all drilled pier submittals have been accepted, additional preconstruction meetings may be required before beginning construction of drilled piers without accepted submittals. The Resident or Bridge Maintenance Engineer, Bridge Construction Engineer, Geotechnical Operations Engineer, Contractor and Drilled Pier Contractor Superintendent will attend preconstruction meetings.

Page 4-12, Article 411-4, Construction Methods, lines 37-39, replace with the following:

For drilled piers constructed with slurry or permanent casings, the pier diameter may be 2" less than the design pier diameter shown in the plans. For all other drilled piers, construct piers with the minimum required diameters shown in the plans except for portions of drilled piers in rock which may be 2" less than the design pier diameter.

Page 4-13, Subarticle 411-4(A), Excavation, line 11, add the following after second sentence in the third paragraph:

See Articles 107-11 and 107-12 for protection of public and private property and control of siltation, dust and air and water pollution from blasting, drilling and excavating with down-the-hole hammers.

Page 4-21, Article 411-7, Measurement and Payment, line 7-8, add “except no payment will be made for *SPT Testing* to determine if temporary casing is necessary.”



DocuSigned by:
Scott A. Hidden
F760CAEB96FC4D3...

4/4/2017

**PROJECT SPECIAL PROVISIONS
GEOENVIRONMENTAL**

CONTAMINATED SOIL (4/19/2016)

The Contractor's attention is directed to the fact that soil contaminated with petroleum hydrocarbon compounds exist within the project area. The known areas of contamination are indicated on corresponding plans sheets. Information relating to these potentially contaminated areas and investigation reports will be available at the following web address by navigating to the correct letting year and month then selecting, "Plans and Proposals", "Alamance U3109A", "GeoEnv Postings":

<http://dotw-xfer01.dot.state.nc.us/dsplan/>

Petroleum contaminated soil may be encountered during any earthwork activities on the project. The Contractor shall only excavate those soils that the Engineer designates necessary to complete a particular task. The Engineer shall determine if soil is contaminated based on petroleum odors and unusual soil staining. Contaminated soil not required to be excavated is to remain in place and undisturbed. Undisturbed soil shall remain in place, whether contaminated or not. The Contractor shall stockpile all contaminated soil excavated from the project in a location approved by the Engineer.

The stockpile shall be created within the property boundaries of the source material and in accordance with the Stockpile Containment Detail found in the plans. If the volume of contaminated material exceeds available space on site, the Contractor shall obtain a permit from the NCDEQ UST Section's Regional Office for off-site temporary storage. The Engineer will notify the GeoEnvironmental Section of the stockpile and the GeoEnvironmental Section will arrange for the testing and disposal of the contaminated stockpile within two weeks of notification.

The quantity of contaminated soil excavated and stockpiled shall be the actual number of tons of material, which has been acceptably excavated, transported, and weighed with certified scales. The quantity of contaminated soil, measured as provided above, shall be paid for at the contract unit price per ton for "Stockpiling Contaminated Soil".

Pay Item

Stockpiling Contaminated Soil

Pay Unit

Ton

DocuSigned by:
Cyrus F. Parker
C96492AF5E824DF...

4/19/2016



OVERHEAD AND DYNAMIC MESSAGE SIGN FOUNDATIONS

Description

Sign foundations include foundations for overhead and dynamic message signs (DMS) supported by metal poles or upright trusses. Sign foundations consist of footings with pedestals or drilled piers with or without grade beams or wings, conduit and anchor rod assemblies. Construct sign foundations in accordance with the contract and accepted submittals. Define “cantilever sign” as an overhead cantilever sign support in accordance with Figure 1-1 of the *AASHTO Standard Specifications for Structural Supports for Highway Signs, Luminaires and Traffic Signals*.

Materials

Use sign foundation materials that meet the *Foundations and Anchor Rod Assemblies for Metal Poles* provision.

Assumed Subsurface Conditions

Assume the following soil parameters and groundwater elevation for sign foundations unless these subsurface conditions are not applicable to sign locations:

- (A) Unit weight (γ) = 120 lb/cf,
- (B) Friction angle (ϕ) = 30°,
- (C) Cohesion (c) = 0 lb/sf and
- (D) Groundwater 7 ft below finished grade.

A subsurface investigation is required if the Engineer determines these assumed subsurface conditions do not apply to a sign location and the sign cannot be moved. Subsurface conditions requiring a subsurface investigation include but are not limited to weathered or hard rock, boulders, very soft or loose soil, muck or shallow groundwater. No extension of completion date or time will be allowed for subsurface investigations.

Subsurface Investigations

Use a prequalified geotechnical consultant to perform one standard penetration test (SPT) boring in accordance with ASTM D1586 at each sign location requiring a subsurface investigation. Rough grade sign locations to within 2 ft of finished grade before beginning drilling. Drill borings to 2 drilled pier diameters below anticipated pier tip elevations or refusal, whichever is higher.

Use the computer software gINT version V8i or later manufactured by Bentley Systems, Inc. with the current NCDOT gINT library and data template to produce SPT boring logs. Provide boring logs sealed by a geologist or engineer licensed in the state of North Carolina.

Sign Foundation Designs

Design sign foundations for the wind zone and clearances shown in the plans and the slope of finished grade at each sign location. Use the assumed soil parameters and groundwater elevation above for sign foundation designs unless a subsurface investigation is required. For sign locations requiring a subsurface investigation, design sign foundations for the subsurface conditions at each sign location. Design footings, pedestals, drilled piers, grade beams and wings in accordance with the 6th Edition of the *AASHTO Standard Specifications for Structural Supports for Highway Signs, Luminaires and Traffic Signals*. In some instances, conflicts with drainage structures may dictate sign foundation types.

Design footings in accordance with Section 4.4 of the *AASHTO Standard Specifications for Highway Bridges*. Do not use an allowable bearing pressure of more than 3,000 lb/sf for footings.

Design drilled piers for side resistance only in accordance with Section 4.6 of the *AASHTO Standard Specifications for Highway Bridges* except reduce ultimate side resistance by 25% for uplift. Use the computer software LPILE version 6.0 or later manufactured by Ensoft, Inc. to analyze drilled piers. Provide drilled pier designs with a horizontal deflection of less than 1" at top of piers. For cantilever signs with single drilled pier foundations supporting metal poles, use wings to resist torsion forces. Provide drilled pier designs with a factor of safety of at least 2.0 for torsion.

For drilled pier sign foundations supporting upright trusses, use dual drilled piers connected with a grade beam having a moment of inertia approximately equal to that of either pier. The Broms' method is acceptable to analyze drilled piers with grade beams instead of LPILE. Use a safety factor of at least 3.5 for the Broms' design method in accordance with C13.6.1.1 of the *AASHTO Standard Specifications for Structural Supports for Highway Signs, Luminaires and Traffic Signals*.

Submit boring logs, if any, working drawings and design calculations for acceptance in accordance with Article 105-2 of the *2012 Standard Specifications*. Submit working drawings showing plan views, required foundation dimensions and elevations and typical sections with reinforcement, conduit and anchor rod assembly details. Include all boring logs, design calculations and LPILE output for sign foundation design submittals. Have sign foundations designed, detailed and sealed by an engineer licensed in the state of North Carolina.

Construction Methods

Construct footings, pedestals, drilled piers, grade beams and wings and install anchor rod assemblies for sign foundations in accordance with the *Foundations and Anchor Rod Assemblies for Metal Poles* provision.

Measurement and Payment

Overhead Footings will be measured and paid in cubic yards. Sign foundations will be measured as the cubic yards of foundation concrete for footings, pedestals, drilled piers, grade beams and wings shown on the accepted submittals. The contract unit price for *Overhead Footings* will be full compensation for providing labor, tools, equipment and foundation materials, stabilizing or shoring excavations and supplying concrete, reinforcing steel, conduit, anchor rod assemblies and any incidentals necessary to construct sign foundations. Subsurface investigations required by the Engineer will be paid as extra work in accordance with Article 104-7 of the *2012 Standard Specifications*.

Payment will be made under:

Pay Item
Overhead Footings

Pay Unit
Cubic Yard

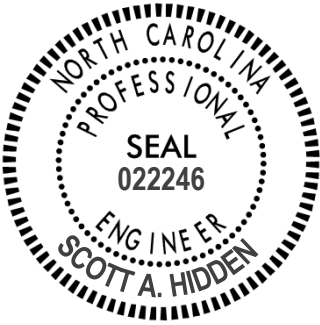

DocuSigned by:
Scott A. Hidden
F760CAEB96FC4D3...

2/6/2017



DocuSigned by:
Renee B. Roach
 B3C6C6F7CF4640D...

2/6/2017

OVERHEAD SIGN SUPPORTS

DESCRIPTION

Design, fabricate, furnish and erect various types of overhead sign assemblies. Fabricate supporting structures using tubular members of either aluminum or steel. The types of overhead sign assemblies included in this specification are span structures, cantilever structures and sign structures attached to bridges.

Materials

Refer to Division 10

| Item | Section |
|---------------------------|----------------|
| Structural Steel | 1072 |
| Overhead Sign Structures | 1096 |
| Signing Materials | 1092 |
| Organic Zinc Repair Paint | 1080-9 |
| Reinforcing Steel | 1070 |
| Direct Tension Indicators | 440 and 1072 |

Construction Methods

A. General

Fabricate overhead sign assemblies in accordance with the details shown in the approved working drawings and the requirements of these specifications.

No welding, cutting or drilling will be permitted in the field, unless approved by the Engineer.

Drill bolt holes and slots to finished size. Holes may also be punched to finish size, provided the diameter of the punched holes is at least twice the thickness of the metal being punched. Flame cutting of bolt holes and slots is not permitted.

Erect sign panels in accordance with the requirement for Type A or B signs as indicated in the plans or Roadway Standard Drawings. Field drill two holes per connection in the Z bars for attaching signs to overhead structures. Provide two U-bolts at each U-bolt connection such as each truss chord to sign hanger and each truss chord to walkway support or light support. Provide two U-bolts at each U-bolt connection where ends of truss chords are supported. The minimum diameter of all U-bolts is 1/2 inch.

For all U-bolt connections of hanger beams to overhead assembly truss chords, provide all U-bolts with a flat washer and double nuts at each end of the U-bolts. All double nuts that are on any U-bolt shall be the same thickness and weight. When assembled, the double nuts shall be brought tight against each other by the use of two wrenches.

Use two coats of a zinc-rich paint to touch up minor scars on all galvanized materials

For high strength bolted connections, use direct tension indicators. Galvanize bolts, nuts and washers in accordance with the Standard Specifications.

B. Shop Drawings

Design the overhead sign supports, including foundations, prior to fabrication. Submit design calculations and working drawings of the designs to the Engineer for review and acceptance.

Have a professional engineer registered in the State of North Carolina perform the computations and render a set of sealed, signed and dated drawings detailing the construction of each structure.

Submit to the Engineer for review and acceptance complete design and fabrication details for each overhead sign assembly, including foundations and brackets for supporting the signs and maintenance walkways, if applicable, electrical control boxes, and lighting luminaires. Base design upon the revised structure line drawings, wind load area and the winds speed shown in the plans, and in accordance with the AASHTO *Standard Specifications for Structural Structures for Highway Signs, Luminaires and Traffic Signals, 6th Edition, 2013 and 2015 Interim Revisions.*

Submit electronic (.pdf) copies of completely detailed working drawings and the design calculations including all design assumptions for each overhead sign assembly to the Engineer for approval prior to fabrication. Working drawings shall include complete design and fabrication details (including foundations), provisions for attaching signs, maintenance walkways (when applicable), lighting luminaires to supporting structures, applicable material specifications, and any other information necessary for procuring and replacing any part of the complete overhead sign assembly.

Allow 40 days for initial working drawing review after the Engineer receives them. If revisions to working drawings are required, an additional 40 days shall be required for review and approval of the final working drawings.

Approval of working drawings by the Engineer shall not relieve the Contractor of responsibility for the correctness of the drawings, or for the fit of all shop and field connections and anchors.

C. Design and Fabrication

The following criteria govern the design of overhead sign assemblies:

Design shall be in accordance with the AASHTO *Standard Specifications for Structural Structures for Highway Signs, Luminaires and Traffic Signals, 6th Edition, 2013 and 2015 Interim Revisions.*

Within this Specification, there are several design criteria that are owner specified. They include:

- Overhead cantilever sign structures shall include galloping loads (exclude four-chord horizontal trusses)
- The Yearly Mean Wind Velocity, V_{mean} , in North Carolina shall be assumed to be 11.6 mph.
- The Fatigue Importance Category used in the design, for each type of structure, shall be for:
 - Cantilevered structures with span greater than 50 feet – Fatigue Importance Category I.
 - Cantilevered structures with span less than or equal to 50 feet – Fatigue Importance Category II.
 - Non-Cantilevered structures – Fatigue Importance Category II.

The following Specification interpretations or criteria shall be used in the design of overhead sign assemblies:

- For design of supporting upright posts or columns, the effective length factor for columns “K”, as provided for in Appendix B, Section B.5, shall be taken as the following, unless otherwise approved by the Engineer:
 - Case 1 For a single upright post of cantilever or span type overhead sign structure, the effective column length factor, “K”, shall be taken as 2.0.
 - Case 2 For twin post truss-type upright post with the post connected to one chord of a horizontal truss, the effective column length factor for that column shall be taken as 2.0.
 - Case 3 For twin post truss-type upright post with the post connected to two truss chords of a horizontal tri-chord or box truss, the effective column length factor for that column shall be taken as 1.65.
- For twin post truss-type uprights, the unbraced length of the post shall be from the chord to post connection to the top of base plate.
- For twin post truss-type uprights, when the post is subject to axial compression, bending moment, shear, and torsion, the post shall satisfy the AASHTO *Standard Specifications for Structural Structures for Highway Signs, Luminaires and Traffic Signals, 6th Edition, 2013 and 2015 Interim Revisions* Equations 5.12.2.1-1, 5.12.2.1-2 and 5.12.2.1-5. To reduce the effects of secondary bending, in lieu of Equation 5.12.2.1-2, the following equation may be used:

$$\frac{f_a}{F_a} + \frac{f_b}{\left(1 - \frac{0.6f_a}{F_e}\right) F_b} + \left(\frac{f_v}{F_v}\right)^2 \leq 1.0$$

Where f_a = Computed axial compression stress at base of post

- The base plate thickness for all uprights and poles shall be a minimum of 2” but not less than that determined by the following criteria and design.

Case 1 Circular or rectangular solid base plates with the upright pole welded to the top surface of the base plate with full penetration butt weld, and where no stiffeners are provided. A base plate with a small center hole, which is less than 1/5 of the upright diameter, and located concentrically with the upright pole, may be considered as a solid base plate.

The magnitude of bending moment in the base plate, induced by the anchoring force of each anchor bolt shall be calculated as $M = (P \times D_1) / 2$.

Case 2 Circular or rectangular base plate with the upright pole socketed into and attached to the base plate with two lines of fillet weld, and where no stiffeners are provided, or any base plate with a center hole that is larger in diameter than 1/5 of the upright diameter. The magnitude of bending moment induced by the anchoring force of each anchor bolt shall be calculated as $M = P \times D_2$.

Where:

- M = bending moment at the critical section of the base plate induced by one anchor bolt
- P = anchoring force of each bolt
- D₁ = horizontal distance between the center of the anchor bolt and the outer face of the upright, or the difference between the radius of the bolt circle and the radius of the upright
- D₂ = horizontal distance between the face of the upright and the face of the anchor bolt nut

- The critical section shall be located at the face of the anchor bolt and perpendicular to the radius of the bolt circle. The overlapped part of two adjacent critical sections shall be considered ineffective.
- The thickness of Case 1 base plate shall not be less than the calculated based on formula for Case 2.
- Uprights, foundations, and trusses that support overhead signs shall be designed in accordance with the Overhead and Dynamic Message Sign Foundations Project Special Provision for the effects of torsion. Torsion shall be considered from dead load eccentricity of these attachments, as well as for the attachments such as supporting brackets, lights, etc., that add to the torsion in the assembly. Truss vertical and horizontal truss diagonals in particular and any other assembly members shall be appropriately sized for these loads
- Uprights, foundations, and trusses that support overhead mounted signs shall be designed for the proposed sign wind area as noted in the contract drawings. Truss vertical and horizontal truss diagonals in particular and any other assembly members shall be appropriately sized for these loads.

For non-cantilevered monotube sign support structures, the following table and figures are considered as a required addition to the AASHTO *Standard Specifications for Structural*

Structures for Highway Signs, Luminaires and Traffic Signals, 6th Edition, 2013 and 2015 Interim Revisions:

| Construction | Detail | Stress Category | Application | Example |
|-----------------------------------|---|------------------------|---|----------------|
| Mechanically Fastened Connections | 25. Bolts in tension | D | Beam column connection for monotube structures | 16 |
| Fillet-Welded Connections | 26. Fillet weld with one side normal to the applied stress | E' | Beam column connection for monotube structures | 16 |
| Mechanically Fastened Connections | 27. High-Strength bolts in tension | D | Monotube or truss-chord splice | 17 |
| Fillet-Welded Connections | 28. Fillet weld with one side normal to the applied stress | E' | Monotube or truss-chord splice | 17 |
| Mechanically Fastened Connections | 29. U-bolts tied to the transverse truss column to keep the chords in place | D | Horizontal truss connection with the vertical truss | 18 |
| Mechanically Fastened Connections | 30. Net section of full-tightened, high-tension bolts in shear | B | Truss-bolted joint | 18 |

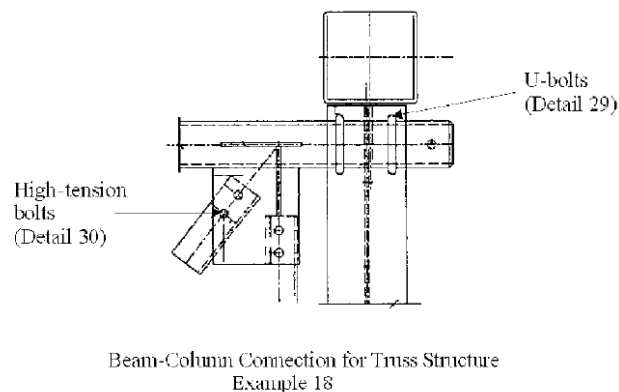
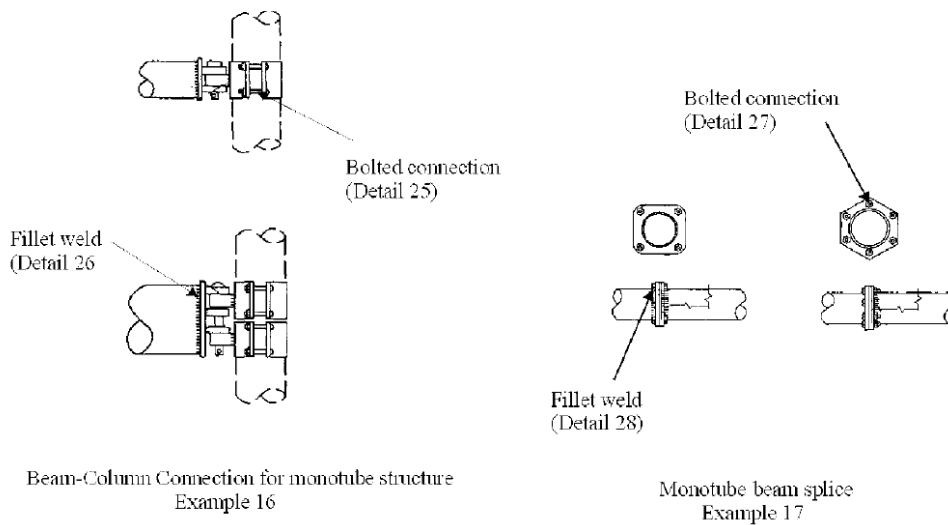

* From NCHRP Report 494 dated 2003

Fabricate all overhead sign assemblies, including but not limited to foundations, in accordance with the details shown on the approved shop drawings and with the requirements of these Specifications.

Fabricate the span and cantilever supporting structures using tubular members of either aluminum or steel, using only one type of material throughout the project. Sign support structures that are to be attached to bridges shall be fabricated using other structural shapes.

Horizontal components of the supporting structures for overhead signs may be of a truss design or a design using singular (monotube) horizontal members to support the sign panels.

Truss or singular member centerline must coincide with the centerline of sign design area shown on the structure line drawing.

Provide permanent camber in addition to dead load camber in accordance with the AASHTO *Standard Specifications for Structural Structures for Highway Signs, Luminaires and Traffic Signals, 6th Edition, 2013 and 2015 Interim Revisions*. Indicate on the shop drawings the amount of camber provided and the method employed in the fabrication of the support to obtain the camber.

Use cantilever sign structures that meet the following design criteria:

- a. Do not exceed an L/150 vertical dead load deflection at the end of the arm due to distortions in the arm and vertical support, where L is the length of the arm from the center of the vertical support to the outer edge of the sign.
- b. Do not exceed an L/40 horizontal deflection at the end of the arm due to distortions in the arm and vertical support, as a result of design wind load.

Fabricate attachment assemblies for mounting signs in a manner that allows easy removal of sign panels for repair.

D. Compensation

The work covered by this section will be paid for at the contract lump sum for each *Supports, Overhead Sign Structure* @ _____. Such price will be full compensation for all work covered by this specification includes all design, fabrication, construction, transportation, and erection of the complete overhead sign structure, supporting structure, hardware, lighting support brackets, preparing and furnishing shop drawings, and attaching the signs to the overhead assembly.

Payment will be made under:

Supports, Overhead Sign Structure @ _____

Lump Sum

TC-1

U-3109A

Alamance County

WORK ZONE TRAFFIC CONTROL Project Special Provisions

SEQUENTIAL FLASHING WARNING LIGHTS:

(10/08/2016)



Description

Furnish and install Sequential Flashing Warning Lights on drums used for merging tapers during nightly work activities on interstates and freeways with speed limits greater than 55 MPH and or facilities that have significant traffic volumes.

The purpose of these lights is to assist the motorist in determining which direction to merge when approaching a lane closure. It's also designed to reduce the number of late merges resulting in devices being struck and having to be reset to maintain positive guidance at the merge point. The successive flashing of the lights shall occur from the upstream end of the merging taper to the downstream end of the merging taper in order to identify the desired vehicle path.

Materials

The Sequential Flashing Warning Lights shall meet all of the requirements for warning lights within the current edition of the Manual of Uniform Traffic Control Devices (MUTCD).

Each light unit shall be capable of operating fully and continuously for a minimum of 200 hours when equipped with a standard battery set.

Each light in the sequence shall be flashed at a rate of not less than 55 times per minute and not more than 75 times per minute. The flash rate and flash duration shall be consistent throughout the sequence.

Supply a Type 3 Certification (Independent Test Lab results) documenting all actual test results for the specified parameters contained in the Institute of Transportation Engineer's (ITE's) *Purchase Specification for Flashing and Steady Burn Warning Lights*. The laboratory shall also identify all manufacturer codes and part numbers for the incandescent lamp or LED clusters, lenses, battery, and circuitry, and the total width of the light with the battery in place. The complete assembly shall be certified as crashworthy when firmly affixed to the channelizing device.

All Sequential Flashing Warning Lights shall be on the NCDOT Work Zone Traffic Control Approved Products List.

Construction Methods

Sequential Flashing Warning Lights are to be used for night time lane closures.

These lights shall flash sequentially beginning with the first light and continuing until the final light.

TC-2

U-3109A

Alamance County

The Sequential Flashing Warning Lights shall automatically flash in sequence when placed on the drums that form the merging taper.

The number of lights used in the drum taper shall equal the number of drums used in the taper.

Drums are the only channelizing device allowed to mount sequential flashing warning lights.

The Sequential Flashing Warning Lights shall be weather independent and visual obstructions shall not interfere with the operation of the lights.

The Sequential Flashing Warning Lights shall automatically sequence when placed in line in an open area with a distance between lights of 10 to 100 feet. A 10 foot stagger in the line of lights shall have no adverse effect on the operation of the lights.

If one light fails, the flashing sequence shall continue. If more than 1 light fails, all of the lights are to be automatically turned to the "off" mode. Non-sequential flashing is prohibited.

When lane closures are not in effect, the Sequential Flashing Warning Lights shall be deactivated.

Measurement and Payment

Sequential Flashing Warning Lights will be measured and paid as the maximum number of sequential flashing warning lights satisfactorily installed and properly functioning at any one time during the life of the project.

This includes all materials and labor to install, maintain and remove all Sequential Flashing Warning Lights.

Pay Item

Sequential Flashing Warning Lights

Pay Unit

Each

TC-3

U-3109A

Alamance County

WORK ZONE TRAFFIC CONTROL Project Special Provisions

WORK ZONE “PERFORMANCE” PAVEMENT MARKINGS:

(06/04/2015)



Description

Furnish and install Work Zone “Performance” pavement markings that delineate the travel way for work zone traffic patterns on high speed (greater than 55 MPH) facilities and or facilities that have traffic volumes greater than 50,000 ADT. The purpose of Work Zone “Performance” pavement marking is to provide a more durable work zone pavement marking that will last the full duration of a traffic pattern during any particular phase of construction without having to be replaced or reapplied for a period of up to 12 months. In addition, they are to provide a higher performance level for both initial and residual retroreflectivity than standard traffic paints to improve nighttime work zone visibility.

Materials

A) General

Use materials in accordance with the Manufacturer’s recommendations that will retain both durability and a minimum retroreflectivity as described elsewhere in this specification for a period of up to 12 months.

In addition, it shall be manufactured to bond successfully to both concrete and asphalt pavements. The pavement marking materials shall be applied in a single application. The following are approved materials to be used for Work Zone “Performance” pavement marking applications.

- Polyurea
- Thermoplastic (Extruded and Sprayed)
- Epoxy
- Polymer (Single System)
- Cold Applied Plastic (Type IV)

B) Material Qualifications/Certifications

Only use Work Zone “Performance” pavement marking materials as listed above that are on the NCDOT Approved Products List. In addition, provide a Type 3 Material Certification for all materials and a Type 3 and Type 4 certification for all reflective media in accordance with Article 106-3, and Section 1087-4 of the North Carolina Standard Specifications For Roads and Structures.

TC-4

U-3109A

Alamance County

(C) Performance

Poor performance of Work Zone “Performance” pavement marking materials at any site, whether or not related to a specific contract may be grounds for removing the material from the NCDOT Approved Products List and or removing from any project under contract.

Construction Methods

Do not use hand applied methods or any other non-truck mounted application equipment /device to install Work Zone “Performance” pavement markings for applications longer than 1000 feet. All Work Zone “Performance” pavement markings are to be installed in a single application.

A) Testing Procedures.

All Work Zone “Performance” pavement markings will be tested by the Department through an independent Mobile Retroreflective Contractor. The Work Zone “Performance” pavement markings will be scanned to ensure the retroreflectivity requirements in Section C of this specification are met.

B) Application Equipment

See Section 1205 of the North Carolina Standard Specifications for Roads and Structures

C) Material Application

The Work Zone “Performance” pavement marking material shall be applied at the following minimum thicknesses:

Polyurea = 20 mils wet

Epoxy = 20 mils wet

Thermoplastic = 50 mils

(Extruded or Sprayed)

Polymer = 20 mils wet

Cold Applied Plastic (IV) = Manufacturer’s recommendation

Unless otherwise stated in the plans, the line widths are as follows:

Edge lines, Solid Lane Lines, Skip and Mini-Skip Lines = 6”

Gorelines = 12”

“No track” dry times for the liquid systems shall be 10 minutes or less. Traffic shall not be placed on any material until it’s sufficiently dry/cured to eliminate wheel tracking.

TC-5

U-3109A

Alamance County

The minimum level of retroreflectivity for any Work Zone “Performance” pavement marking system selected is as follows:

Reflectometer Requirements for Work Zone “Performance” Pavement Markings

| Color | Initial | 6 Months |
|--------|----------------------------|----------------------------|
| White | 375 mcd/lux/m ² | 275 mcd/lux/m ² |
| Yellow | 250 mcd/lux/m ² | 150 mcd/lux/m ² |

The above chart describes the retroreflectivity levels the work zone performance pavement markings are required to meet during initial placement and maintain for a minimum of 6 months.

Initial retroreflective measurements will be taken with a mobile retroreflectometer within 30 days after initial placement. The Contractor shall notify the Engineer 7-10 days prior to the installation of new pavement marking lines. Accordingly, the Engineer will notify the Signing and Delineation Unit’s Standards Engineer so the Mobile Retroreflective Contractors can be scheduled to measure the pavement markings for compliance.

In addition, work zone performance pavement markings are intended to maintain hardy retroreflective levels for the full 12 month duration. If the markings appear to be non-performing within the first 6 months, the Engineer may request additional retroreflectivity readings be taken. If and when this becomes necessary, the same notification procedure as described above will be used to have markings read by the Mobile Retroreflective Contractors.

If measured and found not to be in reasonable compliance, the markings are to be replaced at no cost to the Department.

If Work Zone “Performance” pavement markings are snowplowed within their 12 month expected life, the material shall be durable to withstand a single snow event without showing excessive fatigue in both bond and retroreflectivity. However, if excessive damage has occurred during a single event or multiple snow plow events, resulting in more than 25% of the pavement marking edgelines or skips being physically removed, then the Work Zone “Performance” pavement markings are to be replaced at the contract unit price unless the traffic pattern is to change within 30 days.

Unless the Work Zone “Performance” pavement marking is replaced due to excessive damage, it shall meet the following minimum retroreflectivity values within the single snow event.

TC-6

U-3109A

Alamance County

Reflectometer Requirements for Work Zone “Performance” Pavement Markings After Single Snow Event

| Color | MINIMUM |
|--------|----------------|
| White | 150 mcd/lux/m2 |
| Yellow | 100 mcd/lux/m2 |

If the work zone experiences more than more than 1 snow event requiring snowplowing, the retroreflectivity numbers in the chart no longer apply. The Engineer will determine if the pavement markings are still performing adequately or if replacement is necessary due to excessive damage caused by snowplow activities. If the markings are found to be deficient, they shall be replaced at the contract unit price unless the traffic pattern is to change within 30 days.

D) Surface Preparation

All pavement surfaces to receive Work Zone “Performance” pavement markings are to be swept clean and prepared in accordance with the Manufacturer’s recommendation.

E) Temperature and Weather Limitations

Do not apply Work Zone “Performance” pavement markings unless the ambient air temperature and the pavement temperature is 50°F or higher for thermoplastic and is 40°F or higher for all other materials. Do not install unless the pavement surface is completely dry and not within 4 hours of a heavy rain event such as a thunderstorm with rainfall intensities greater than 1 inch/per hour.

In the event a traffic shift has to take place when the air and pavement temperatures are below the required minimums or if a rain event occurs prior to or during a planned traffic shift, upon approval by the Engineer, an acceptable alternative is to install temporary pavement marking. Use 1 application of standard traffic paint to produce a 4” line with at 15 mils (wet). Beads shall also be applied to provide proper retroreflectivity until the “performance” material can be installed. Payment will be made at the contract unit price for 4” paint. The Work Zone “Performance” pavement markings shall be applied within 90 days of installation of the temporary pavement markings.

Maintenance

Replace any Work Zone “Performance” pavement material that prematurely fails due to debonding or excessive wearing where it doesn’t maintain its retroreflectivity for the required 12 month duration. Any traffic control and Work Zone “Performance” pavement marking costs due to replacement is at no cost to the Department unless it’s due to excessive damage caused by snowplow damage.

TC-7

U-3109A

Alamance County

Measurement and Payment

Work Zone “Performance” pavement markings will be measured and paid by the linear foot that’s satisfactorily placed and accepted by the Engineer. The quantity of Work Zone “Performance” pavement marking- solid lines, will be the summation of the linear feet of solid line measured end- to-end of the line. The quantity of skip or broken lines will be the summation of the linear feet derived by multiplying the nominal length of a line by the number of broken lines satisfactorily placed.

Payment will be made under:

Pay Item:

Pay Unit

Work Zone “Performance” Pavement Marking Lines (__ ”)

Linear Foot

TC-8

U-3109A

Alamance County

WORK ZONE TRAFFIC CONTROL Project Special Provisions



WORK ZONE TRAFFIC “PATTERN MASKING”:

(2/8/2017)

Description

Furnish and install Work Zone Traffic “Pattern Masking” material for placement on existing asphalt or concrete pavements during work zone operations. The Work Zone Traffic “Pattern Masking” material shall be black in color and used during traffic pattern changes to completely cover the entire pavement surface; thus masking/concealing the existing pavement markings and allowing the revised work zone pavement markings to be placed on a newly applied black surface. Its purpose is to eliminate the grind marks and “ghost markings” on pavement surfaces which can create motorist confusion and pavement damage while providing an incomparable contrast between the revitalized black pavement color and newly applied pavement markings for work zone patterns of up to a year.

Materials

A) General

Use materials in accordance with Manufacturer’s recommendations that will retain a black color for a period of up to 12 months. The black material shall be a flat black color when fully cured and shall completely mask/conceal the existing pavement markings for the same 12 month period.

The material shall not exhibit glare or retroreflectance in either day or night conditions. To ensure the material provides ample concealment and doesn’t exhibit excessive glare, the material opaqueness shall be a minimum of 95% and the retroreflective properties shall not exceed 4 mcd/lux/m².

It shall not adversely affect the ability of the pavement to drain water or make the pavement adversely slick in either dry and wet conditions and shall meet the skid properties as described in Section C below.

The material shall not contain any petroleum components and shall not contain any Volatile Organic Compounds (VOC’s).

The material shall not exhibit excessive cracking or create excessive cracking to the pavement surface after placement.

In addition, it shall be manufactured to bond successfully to both concrete and asphalt pavements and allow resurfacing treatments to be applied directly over its surface without having to be removed for successful bonding of the new asphalt or concrete overlays.

TC-9

U-3109A

Alamance County

It should also be manufactured to receive any type of polyurea, epoxy, polymer, cold applied plastic, or thermoplastic pavement marking materials.

B) Material Qualifications/Certifications

Use Work Zone Traffic “Pattern Masking” materials that are on the NCDOT Approved Products List. Provide a Type 3 (Manufacturers) Certification in accordance with Article 106-3 in the North Carolina Standard Specifications for Roads and Structures to ensure the material meets or exceeds the requirements in this specification.

In addition, provide a Type 5 (Typical Certified Test Report) Certification in accordance with Article 106-3 in the North Carolina Standard Specifications for Roads and Structures that ensures the material has been tested by an independent testing company that meets or exceeds the braking/skid requirements as described in Section (C) below.

(C) Performance

The Work Zone Traffic “Pattern Masking” material shall be tested by an independent test laboratory for skid properties according to the test standards in ASTM E274 or ASTM E303-93 (2008). The material shall provide minimum frictional resistance numbers when tested with either test standard. The minimum average Skid Number (SN) for ASTM E274 is 37. The minimum average British Pendulum Number (BPN) for ASTM E303-93 (2008) is 37.

At any time this material fails to keep previously installed pavement markings concealed resulting in conflicting traffic patterns, it is not meeting the requirements and intention of this specification and shall be replaced immediately. Also, the work zone travel lane shall retain its black distinguishable appearance throughout the life of the traffic pattern. Normal wearing is expected in the wheel paths of the travel lanes, but the work zone travel lanes shall always have a noticeable black appearance at all times during the expected 12 month traffic pattern life. Replace any material that prematurely fails to keep the pavement markings concealed or doesn't retain its black color contrast for the required 12 month duration.

Poor performance of Work Zone Traffic “Pattern Masking” material at any site, whether or not related to a specific contract may be grounds for removing the material from the NCDOT Approved Products List and or removing from any project under contract.

Construction Methods

A) Application Equipment

The equipment to apply Work Zone Traffic “Pattern Masking” material shall be truck mounted pneumatic or airless spray machines with suitable arrangement of atomizing nozzles and controls to cover the entire pavement surface to achieve uniform coverage with consistent thickness as required in this specification. Do not use hand applied methods or any other non-truck mounted application equipment or device to install material for applications longer than 1,000 feet.

TC-10

U-3109A

Alamance County

The application spray equipment shall be set up in such a manner to apply the Work Zone Traffic “Pattern Masking” material in spray pattern widths to ensure complete and uniform coverage of the entire travelway and to reduce the overlap from multiple passes. If the application equipment is not/ equipped to spray a full 12’ travel lane in a single pass, it shall be set-up to spray a 6 foot minimum width. No more than 2 passes per travel lane will be allowed. A 1” overlap width is required when applying the material in less than the full width of the travel lane.

B) Material Application

The Work Zone Traffic “Pattern Masking” material is to be applied to the full width and length of the pavement surface where traffic patterns are to change thus masking/concealing the existing pavement markings as well as providing a new black surface for the placement of the revised pavement markings. The masking/concealment of individual pavement marking edge lines, skips, mini skips, lane lines or gore lines is not allowed.

The Work Zone Traffic “Pattern Masking” material shall be applied at a uniform thickness of approximately 16 mils (+/-) directly onto the existing pavement. The material shall be set and/or cured to receive pavement markings within 10 minutes of installation according to the temperature requirements stated within this specification.

C) Surface Preparation

i) Asphalt- The existing pavement surface shall be swept clean and prepared in accordance with the Manufacturer’s recommendations to receive the Work Zone Traffic “Pattern Masking” material. Although no existing pavement marking line removal is required, any loose, flaking or other laitance material from existing markings shall be machine broomed or scarified as directed by Manufacturer before placing the Work Zone Traffic “Pattern Masking” material.

ii) Concrete- The *existing* concrete surface shall be swept clean and prepared in accordance with the Manufacturer’s recommendations to receive the Work Zone Traffic “Pattern Masking” material.

Although no existing pavement marking line removal is required, any loose, flaking or other laitance material from existing markings shall be machine broomed or scarified as directed by Manufacturer before placing the Work Zone Traffic “Pattern Masking” material.

NOTE: For newly placed concrete pavements, newly installed concrete bridge decks or existing concrete pavements that do not receive a surface treatment, Work Zone Traffic “Pattern Masking” Material shall not be placed. The conflicting pavement marking lines shall be removed by water blasting methods only.

TC-11

U-3109A

Alamance County

D) Temperature and Weather Limitations

Do not apply Work Zone Traffic “Pattern Masking” material unless the ambient air temperature and the pavement temperature is 40°F or higher. Do not install unless the pavement surface is completely dry and not within 4 hours of a significant rain event such as a thunderstorm with rainfall intensities greater than 1 inch/per hour. Always follow the Manufacturer’s recommendations for placement during periods of excessive humidity.

Maintenance

There should be no required maintenance of the Work Zone Traffic “Pattern Masking” material. Replace any Work Zone Traffic “Pattern Masking” material that prematurely fails to keep pavement markings masked/concealed for the full 12 month duration. Any traffic control or material costs due to replacement will be at no cost to the Department.

Measurement and Payment

Work Zone Traffic “Pattern Masking” material will be measured and paid by the square foot. The quantity of material to be paid is calculated by multiplying the length by the width of all lanes affected by each work zone traffic pattern change.

Pay Item

Work Zone Traffic “Pattern Masking”

Pay Unit

Square Foot

PROJECT SPECIAL PROVISIONS

Utility Construction

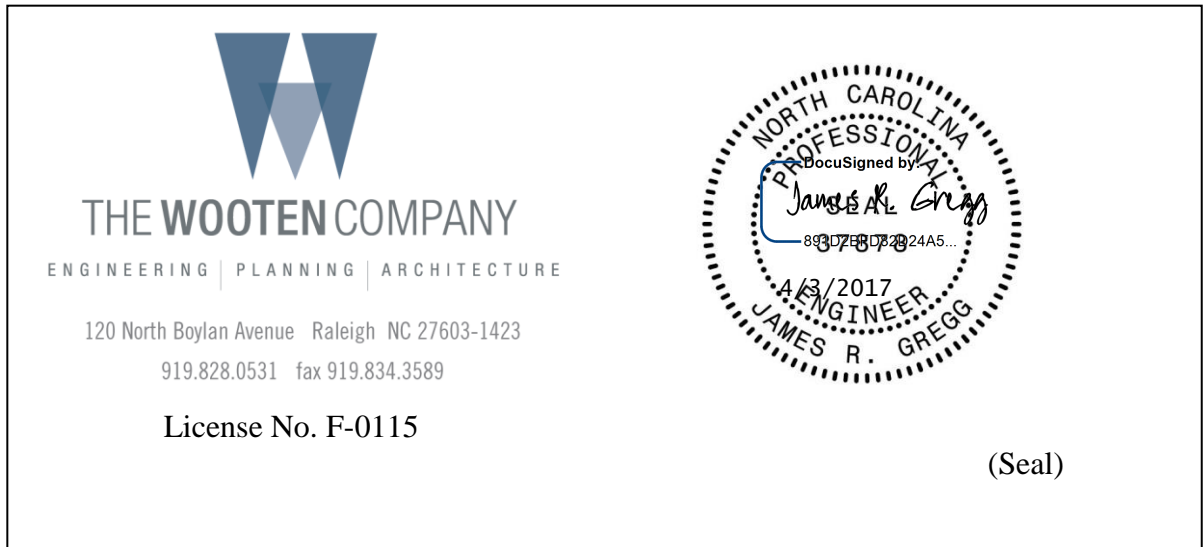

UTILITY OWNER

8" Sewer Force Main:
Alamance-Burlington School System
Jay Fuller, Director of Facilities and Maintenance
307 Prison Camp Road
Graham, NC 27253
Office: 336-570-6482
Cell: 336-516-3322
Fax: 336-570-6485
Email: jay_fuller@abss.k12.nc.us

Revise the 2012 NCDOT Standard Specifications as follows:

Page 10-57, Sub-Article 1034-2 Plastic Pipe, Sub-Article (B) PVC Force Main Sewer Pipe

Add the following section (C) Fusible PVC:

- (C) FUSIBLE POLYVINYLCHLORIDE (FPVC) PRESSURE PIPE
 - A. Fusible polyvinylchloride pipe shall conform to AWWA C900 standard.
 - B. Outside diameter shall conform to ductile-iron pipe.
 - C. Pipe shall be pressure class 235 with a standard dimension ratio of DR 18.

PROJECT SPECIAL PROVISIONS

Utility Construction

- D. Fusible polyvinylchloride pipe shall be extruded with plain ends. The ends shall be square to the pipe and free of any bevel or chamfer. There shall be no bell or gasket of any kind incorporated into the pipe.
- E. Fusible polyvinylchloride pipe shall be manufactured in a standard 40' or 45' nominal length, or custom lengths as specified.
- F. Fusible polyvinylchloride pipe shall be green in color for wastewater use.
- G. Pipe shall be marked as follows:
 - 1. Nominal pipe size
 - 2. PVC
 - 3. Dimension Ratio, Standard Dimension Ratio, or Schedule
 - 4. AWWA pressure class
 - 5. AWWA standard designation number
 - 6. Extrusion production-record code
 - 7. Trademark or trade name
 - 8. Cell Classification 12454 and/or PVC material code 1120 may also be included
- H. Pipe shall be homogeneous throughout and be free of visible cracks, holes, foreign material, blisters, or other visible deleterious faults.
- I. Fittings shall conform to AWWA C110, or C153 and have mechanical joints and be restrained with series 2000PV Megalug mechanical joint restraint or approved equal. Fittings shall be made of gray-iron or ductile-iron. Interior of fittings shall be lined with 401-type ceramic epoxy.
 - 1. Bolts and nuts for buried service shall be made of non-corrosive, high-strength, low-alloy steel having the characteristics specified in ANSI/AWWA C111/A21.11, regardless of any other protective coating.
- J. Encase fittings in polyethylene conforming to AWWA C105 where indicated on the Drawings.
- K. Fusion joints
 - 1. Unless otherwise specified, fusible polyvinylchloride pipe lengths shall be assembled in the field with butt-fused joints. The Contractor shall follow the pipe supplier's written guidelines for this procedure. All fusion joints shall be completed as described in this specification.
- L. Fusion Process
 - 1. General
 - a. Fusible polyvinylchloride pipe will be handled in a safe and non-destructive manner before, during, and after the fusion process and in accordance with this specification and pipe supplier's guidelines.
 - b. Fusible polyvinylchloride pipe will be fused by qualified fusion technicians, as documented by the pipe supplier.

PROJECT SPECIAL PROVISIONS

Utility Construction

- c. Each fusion joint shall be recorded and logged by an electronic monitoring device (data logger) connected to the fusion machine.
 - d. Only appropriately sized and outfitted fusion machines that have been approved by the pipe supplier shall be used for the fusion process. Fusion machines must incorporate the following elements:
 - 1) HEAT PLATE - Heat plates shall be in good condition with no deep gouges or scratches. Plates shall be clean and free of any debris or contamination. Heater controls shall function properly; cord and plug shall be in good condition. The appropriately sized heat plate shall be capable of maintaining a uniform and consistent heat profile and temperature for the size of pipe being fused, per the pipe supplier's guidelines.
 - 2) CARRIAGE – Carriage shall travel smoothly with no binding at less than 50 psi. Jaws shall be in good condition with proper inserts for the pipe size being fused. Insert pins shall be installed with no interference to carriage travel.
 - 3) GENERAL MACHINE - Overview of machine body shall yield no obvious defects, missing parts, or potential safety issues during fusion.
 - 4) DATA LOGGING DEVICE – An approved datalogging device with the current version of the pipe supplier's recommended and compatible software shall be used. Datalogging device operations and maintenance manual shall be with the unit at all times. If fusing for extended periods of time, an independent 110V power source shall be available to extend battery life.
 - e. Other equipment specifically required for the fusion process shall include the following:
 - 1) Pipe rollers shall be used for support of pipe to either side of the machine
 - 2) A weather protection canopy that allows full machine motion of the heat plate, fusion assembly and carriage shall be provided for fusion in inclement, extreme temperatures, and /or windy weather, per the pipe supplier's recommendations.
 - 3) An infrared (IR) pyrometer for checking pipe and heat plate temperatures.
 - 4) Fusion machine operations and maintenance manual shall be kept with the fusion machine at all times.
 - 5) Facing blades specifically designed for cutting fusible polyvinylchloride pipe shall be used.
2. Joint Recording
- a. Each fusion joint shall be recorded and logged by an electronic monitoring device (data logger) connected to the fusion machine. The fusion data logging and joint report shall be generated by software developed specifically for the butt-fusion of fusible

PROJECT SPECIAL PROVISIONS

Utility Construction

polyvinyl chloride pipe. The software shall register and/or record the parameters required by the pipe supplier and these specifications. Data not logged by the data logger shall be logged manually and be included in the Fusion Technician's joint report.

- b. Fusion joint documentation shall include the following:
- 1) Pipe size and Thickness
 - 2) Machine Size
 - 3) Fusion Technician Identification
 - 4) Job Identification
 - 5) Fusion Joint Number
 - 6) Fusion, Heating, and Drag Pressure Settings
 - 7) Heat Plate Temperature
 - 8) Time Stamp
 - 9) Heating and Cool Down Time of Fusion
 - 10) Ambient Temperature

Page 15-1, Sub-Article 1500-2 Cooperation with the Utility Owner, paragraph 2:

Add the following sentences:

The utility owner is Alamance-Burlington School System. Contact information can be found on page UC-1 under "Utility Owner".

Page 15-1, Sub-Article 1500-2 Cooperation with the Utility Owner, paragraph 4:

Delete "24 hours" and replace with "48 hours".

Page 15-2, Sub-Article 1500-9 Placing Pipelines into Service

Add the following to the last paragraph:

Obtain approval from the NCDEQ-Wastewater Branch prior to placing a new line into service.

Page 15-4, Sub-Article 1505-3 (C) Bedding, Sub-Article 1505-3 (E), Thrust Restraint

Note: Thrust restraints shall be installed as shown on the drawings.

Page 15-6, Sub-Article 1510-3 (B), Testing and Sterilization

Change the allowable leakage formula to:

$$W = LD\sqrt{P} \div 148,000$$

Page 15-11, Sub-article 1520-3(A)(2) Testing, line 5,

replace the second paragraph with the following:

Test all 24" and smaller gravity sewer lines for leakage using infiltration, exfiltration, or air test. Perform visual inspection on gravity sewer lines larger than 24". Perform line and grade testing and deflection testing on all gravity sewer lines.

PROJECT SPECIAL PROVISIONS

Utilities by Others



General:

The following utility companies have facilities that will be in conflict with the construction of this project:

- A) Duke Energy– Power (Distribution)
- B) Duke Energy – Power (Transmission)
- C) AT&T – Communications
- D) CenturyLink – Communications
- E) City of Mebane – Water and Sewer
- F) Orange/Alamance Water - Water
- G) PSNC – Gas (Distribution)
- H) Time Warner Cable - Communications

The conflicting facilities will be adjusted prior to the date of availability, unless otherwise noted and are therefore listed in these special provisions for the benefit of the Contractor. All utility work listed herein will be done by the utility owners. All utilities are shown on the plans from the best available information.

The Contractor’s attention is directed to Article 105-8 of the 2012 Standard Specifications.

Utilities Requiring Adjustment:

Utility relocations are shown on the Utilities by Others Plans.

- A) Duke Energy- Power (Distribution)
 - 1) Duke Energy will install and relocate distribution utility poles, aerial and underground lines within the project limits. This work will be completed by 11/1/17.
 - 2) Contact person for Duke Energy (Distribution) is Mr. Eddie Watkins at 919-518-5248

PROJECT SPECIAL PROVISIONS

Utilities by Others



B) Duke Energy – Power (Transmission)

- 1) Duke Energy Transmission has three areas of conflict within the project limits that will be relocated. This work will be completed (Excluding the facilities on Highway 70) by 6/1/17. The relocation work along Highway 70 will be completed by 8/1/18
- 2) Contact person for Duke Energy Transmission is Mr. Jamie Hicks at 980-373-1979

C) AT&T - Communications

- 1) AT&T will relocate both aerial and underground lines within the project limits. This work will be completed by 2/1/18.
- 2) Contact person for AT&T is Mr. Ron Stokes at 366-682-1090.

D) CenturyLink – Communications

- 1) Century Link will relocate both aerial and underground lines within the project limits. This work will be completed by 10/1/17.
- 2) Contact person for CenturyLink is Mr. Kevin Godwin at 910-336-2142.

E) City of Mebane – Water and Sewer

- 1) The City of Mebane will relocate and adjust water and sewer lines within the project limits. This work will be completed by 7/1/17.
- 2) Contact person for City of Mebane Water is Mr. Troy King at 336-226-5534.

PROJECT SPECIAL PROVISIONS

Utilities by Others



F) Orange/ Alamance Water - Water

- 1) Orange/Alamance Water will relocate and adjust water lines within the project limits. This work will be completed by 5/1/17.
- 2) Contact person for Orange/Alamance Water is Mr. Mike Aquesta at 919-971-5859.

G) PSNC – Gas (Distribution)

- 1) PSNC will relocate and adjust both steel and plastic natural gas lines within the project limits. This work will be completed by 8/1/17.
- 2) Contact person for PSNC is Ms. Rhonda Lemon at 919-367-2755.

H) Time Warner Cable - Communication

- 1) Time Warner Cable will relocate both aerial and underground lines within the project limits. This work will be completed by May 1, 2018.
- 2) Contact person for Time Warner Cable is Mr. Roger Stanfield at 336-215-3742.

**Project Special Provisions
Erosion Control**

STABILIZATION REQUIREMENTS:

(3-11-2016)

Stabilization for this project shall comply with the time frame guidelines as specified by the NCG-010000 general construction permit effective August 3, 2011 issued by the North Carolina Department of Environment and Natural Resources Division of Water Quality. Temporary or permanent ground cover stabilization shall occur within 7 calendar days from the last land-disturbing activity, with the following exceptions in which temporary or permanent ground cover shall be provided in 14 calendar days from the last land-disturbing activity:

- Slopes between 2:1 and 3:1, with a slope length of 10 ft. or less
- Slopes 3:1 or flatter, with a slope of length of 50 ft. or less
- Slopes 4:1 or flatter

The stabilization timeframe for High Quality Water (HQW) Zones shall be 7 calendar days with no exceptions for slope grades or lengths. High Quality Water Zones (HQW) Zones are defined by North Carolina Administrative Code 15A NCAC 04A.0105 (25). Temporary and permanent ground cover stabilization shall be achieved in accordance with the provisions in this contract and as directed.

SEEDING AND MULCHING:

(East)

The kinds of seed and fertilizer, and the rates of application of seed, fertilizer, and limestone, shall be as stated below. During periods of overlapping dates, the kind of seed to be used shall be determined. All rates are in pounds per acre.

All Roadway Areas

| March 1 - August 31 | | September 1 - February 28 | |
|----------------------------|-----------------------|----------------------------------|-------------------------|
| 50# | Tall Fescue | 50# | Tall Fescue |
| 10# | Centipede | 10# | Centipede |
| 25# | Bermudagrass (hulled) | 35# | Bermudagrass (unhulled) |
| 500# | Fertilizer | 500# | Fertilizer |
| 4000# | Limestone | 4000# | Limestone |

Waste and Borrow Locations

| March 1 – August 31 | | September 1 - February 28 | |
|----------------------------|-----------------------|----------------------------------|-------------------------|
| 75# | Tall Fescue | 75# | Tall Fescue |
| 25# | Bermudagrass (hulled) | 35# | Bermudagrass (unhulled) |
| 500# | Fertilizer | 500# | Fertilizer |
| 4000# | Limestone | 4000# | Limestone |

Note: 50# of Bahiagrass may be substituted for either Centipede or Bermudagrass only upon Engineer's request.

Approved Tall Fescue Cultivars

| | | | |
|----------------------------|-----------------|-----------------|--------------------|
| 06 Dust | Escalade | Justice | Serengeti |
| 2 nd Millennium | Essential | Kalahari | Shelby |
| 3 rd Millennium | Evergreen 2 | Kitty Hawk 2000 | Sheridan |
| Apache III | Falcon IV | Legitimate | Signia |
| Avenger | Falcon NG | Lexington | Silver Hawk |
| Barlexas | Falcon V | LSD | Sliverstar |
| Barlexas II | Faith | Magellan | Shenandoah Elite |
| Bar Fa | Fat Cat | Matador | Sidewinder |
| Barrera | Festnova | Millennium SRP | Skyline |
| Barrington | Fidelity | Monet | Solara |
| Barrobusto | Finelawn Elite | Mustang 4 | Southern Choice II |
| Barvado | Finelawn Xpress | Ninja 2 | Speedway |
| Biltmore | Finesse II | Ol' Glory | Spyder LS |
| Bingo | Firebird | Olympic Gold | Sunset Gold |
| Bizem | Firecracker LS | Padre | Taccoa |
| Blackwatch | Firenza | Patagonia | Tanzania |
| Blade Runner II | Five Point | Pedigree | Trio |
| Bonsai | Focus | Picasso | Tahoe II |
| Braveheart | Forte | Piedmont | Talladega |
| Bravo | Garrison | Plantation | Tarheel |
| Bullseye | Gazelle II | Proseeds 5301 | Terrano |
| Cannavaro | Gold Medallion | Prospect | Titan ltd |
| Catalyst | Grande 3 | Pure Gold | Titanium LS |
| Cayenne | Greenbrooks | Quest | Tracer |
| Cessane Rz | Greenkeeper | Raptor II | Traverse SRP |
| Chipper | Gremlin | Rebel Exeda | Tulsa Time |
| Cochise IV | Greystone | Rebel Sentry | Turbo |
| Constitution | Guardian 21 | Rebel IV | Turbo RZ |
| Corgi | Guardian 41 | Regiment II | Tuxedo RZ |
| Corona | Hemi | Regenerate | Ultimate |
| Coyote | Honky Tonk | Rendition | Venture |
| Darlington | Hot Rod | Rhambler 2 SRP | Umbrella |
| Davinci | Hunter | Rembrandt | Van Gogh |
| Desire | Inferno | Reunion | Watchdog |
| Dominion | Innovator | Riverside | Wolfpack II |
| Dynamic | Integrity | RNP | Xtremegreen |
| Dynasty | Jaguar 3 | Rocket | |
| Endeavor | Jamboree | Scorpion | |

On cut and fill slopes 2:1 or steeper Centipede shall be applied at the rate of 5 pounds per acre and add 20# of Sericea Lespedeza from January 1 - December 31.

Fertilizer shall be 10-20-20 analysis. A different analysis of fertilizer may be used provided the 1-2-2 ratio is maintained and the rate of application adjusted to provide the same amount of plant food as a 10-20-20 analysis and as directed.

Native Grass Seeding And Mulching

(West)

Native Grass Seeding and Mulching shall be performed on the disturbed areas of wetlands and riparian areas, and adjacent to Stream Relocation and/or trout stream construction within a 50 foot zone on both sides of the stream or depression, measured from top of stream bank or center of depression. The stream bank of the stream relocation shall be seeded by a method that does not alter the typical cross section of the stream bank. Native Grass Seeding and Mulching shall also be performed in the permanent soil reinforcement mat section of preformed scour holes, and in other areas as directed.

The kinds of seed and fertilizer, and the rates of application of seed, fertilizer, and limestone, shall be as stated below. During periods of overlapping dates, the kind of seed to be used shall be determined. All rates are in pounds per acre.

August 1 - June 1

- 18# Creeping Red Fescue
- 8# Big Bluestem
- 6# Indiangrass
- 4# Switchgrass
- 35# Rye Grain
- 500# Fertilizer
- 4000# Limestone

May 1 – September 1

- 18# Creeping Red Fescue
- 8# Big Bluestem
- 6# Indiangrass
- 4# Switchgrass
- 25# German or Browntop Millet
- 500# Fertilizer
- 4000# Limestone

Approved Creeping Red Fescue Cultivars:

- Aberdeen
- Boreal
- Epic
- Cindy Lou

Fertilizer shall be 10-20-20 analysis. A different analysis of fertilizer may be used provided the 1-2-2 ratio is maintained and the rate of application adjusted to provide the same amount of plant food as a 10-20-20 analysis and as directed.

Native Grass Seeding and Mulching shall be performed in accordance with Section 1660 of the *Standard Specifications* and vegetative cover sufficient to restrain erosion shall be installed immediately following grade establishment.

Measurement and Payment

Native Grass *Seeding and Mulching* will be measured and paid for in accordance with Article 1660-8 of the *Standard Specifications*.

NUTRIENT MANAGEMENT TRAINING REQUIREMENTS:

The person(s) responsible for applying fertilizer or person(s) conducting the application of fertilizer on this project within the Jordan Lake or Falls Lake Watershed shall complete the following web-based training prior to performing this work:

<http://www.jordanlake.org/web/jordanlake/fertilizer-management>

A certificate of completion must be presented by the person(s) responsible for fertilizer application or person(s) conducting the application of fertilizer prior to performing fertilizer application on the project within the limits of the Jordan Lake or Fall Lake Watershed.

TEMPORARY SEEDING:

Fertilizer shall be the same analysis as specified for *Seeding and Mulching* and applied at the rate of 400 pounds and seeded at the rate of 50 pounds per acre. Sweet Sudan Grass, German Millet or Browntop Millet shall be used in summer months and Rye Grain during the remainder of the year. The Engineer will determine the exact dates for using each kind of seed.

FERTILIZER TOPDRESSING:

Fertilizer used for topdressing on all roadway areas except slopes 2:1 and steeper shall be 10-20-20 grade and shall be applied at the rate of 500 pounds per acre. A different analysis of fertilizer may be used provided the 1-2-2 ratio is maintained and the rate of application adjusted to provide the same amount of plant food as 10-20-20 analysis and as directed.

Fertilizer used for topdressing on slopes 2:1 and steeper and waste and borrow areas shall be 16-8-8 grade and shall be applied at the rate of 500 pounds per acre. A different analysis of fertilizer may be used provided the 2-1-1 ratio is maintained and the rate of application adjusted to provide the same amount of plant food as 16-8-8 analysis and as directed.

SUPPLEMENTAL SEEDING:

The kinds of seed and proportions shall be the same as specified for *Seeding and Mulching*, with the exception that no centipede seed will be used in the seed mix for supplemental seeding. The rate of application for supplemental seeding may vary from 25# to 75# per acre. The actual rate per acre will be determined prior to the time of topdressing and the Contractor will be notified in writing of the rate per acre, total quantity needed, and areas on which to apply the supplemental seed. Minimum tillage equipment, consisting of a sod seeder shall be used for incorporating seed into the soil as to prevent disturbance of existing vegetation. A clodbuster (ball and chain) may be used where degree of slope prevents the use of a sod seeder.

MOWING:

The minimum mowing height on this project shall be 4 inches.

LAWN TYPE APPEARANCE:

All areas adjacent to lawns must be hand finished as directed to give a lawn type appearance. Remove all trash, debris, and stones $\frac{3}{4}$ " and larger in diameter or other obstructions that could interfere with providing a smooth lawn type appearance. These areas shall be reseeded to match their original vegetative conditions, unless directed otherwise by the Field Operations Engineer.

REFORESTATION:**Description**

Reforestation will be planted in areas as directed. *Reforestation* is not shown on the plan sheets. See the Reforestation Detail Sheet.

All non-maintained riparian buffers impacted by the placement of temporary fill or clearing activities shall be restored to the preconstruction contours and revegetated with native woody species.

The entire *Reforestation* operation shall comply with the requirements of Section 1670 of the *Standard Specifications*.

Materials

Reforestation shall be bare root seedlings 12"-18" tall.

Construction Methods

Reforestation shall be planted as soon as practical following permanent *Seeding and Mulching*. The seedlings shall be planted in a 16-foot wide swath adjacent to mowing pattern line, or as directed.

Root dip: The roots of reforestation seedlings shall be coated with a slurry of water, and either a fine clay (kaolin) or a superabsorbent that is designated as a bare root dip. The type, mixture ratio, method of application, and the time of application shall be submitted to the Engineer for approval.

With the approval of the Engineer, seedlings may be coated before delivery to the job or at the time of planting, but at no time shall the roots of the seedlings be allowed to dry out. The roots shall be moistened immediately prior to planting.

Seasonal Limitations: *Reforestation* shall be planted from November 15 through March 15.

Measurement and Payment

Reforestation will be measured and paid for in accordance with Article 1670-17 of the *Standard Specifications*.

RESPONSE FOR EROSION CONTROL:**Description**

Furnish the labor, materials, tools and equipment necessary to move personnel, equipment, and supplies to the project necessary for the pursuit of any or all of the following work as shown herein, by an approved subcontractor.

| Section | Erosion Control Item | Unit |
|----------------|----------------------------------|-------------|
| 1605 | Temporary Silt Fence | LF |
| 1606 | Special Sediment Control Fence | LF/TON |
| 1615 | Temporary Mulching | ACR |
| 1620 | Seed - Temporary Seeding | LB |
| 1620 | Fertilizer - Temporary Seeding | TN |
| 1631 | Matting for Erosion Control | SY |
| SP | Coir Fiber Mat | SY |
| 1640 | Coir Fiber Baffles | LF |
| SP | Permanent Soil Reinforcement Mat | SY |
| 1660 | Seeding and Mulching | ACR |
| 1661 | Seed - Repair Seeding | LB |
| 1661 | Fertilizer - Repair Seeding | TON |
| 1662 | Seed - Supplemental Seeding | LB |
| 1665 | Fertilizer Topdressing | TON |
| SP | Safety/Highly Visible Fencing | LF |
| SP | Response for Erosion Control | EA |

Construction Methods

Provide an approved subcontractor who performs an erosion control action as described in the NPDES Inspection Form SPPP30. Each erosion control action may include one or more of the above work items.

Measurement and Payment

Response for Erosion Control will be measured and paid for by counting the actual number of times the subcontractor moves onto the project, including borrow and waste sites, and satisfactorily completes an erosion control action described in Form 1675. The provisions of Article 104-5 of the *Standard Specifications* will not apply to this item of work.

Payment will be made under:

| Pay Item | Pay Unit |
|------------------------------|-----------------|
| Response for Erosion Control | Each |

303(d) IMPAIRED WATERS LIST:

Black Creek (Graham-Mebane Reservoir), which has been identified on the 303(d) list of impaired waters as impaired for sedimentation and/or turbidity, is within one mile of the project and receives drainage from the project. The Contractor shall adhere to all conditions and/or regulations required for impacts to these waters.

HIGH QUALITY WATERS:

Description

The Unnamed Tributary to Mill Creek, Mill Creek, and Black Creek (Graham-Mebane Reservoir) have been identified as high quality waters. This designation requires special procedures to be used for clearing and grubbing, temporary stream crossings, and grading operations within the High Quality Water Zone and as designated by the Engineer. The High Quality Water Zones are identified on the plans as Environmentally Sensitive Areas. This also requires special procedures to be used for seeding and mulching and staged seeding.

The High Quality Water Zone/Environmentally Sensitive Area shall be defined as a 50-foot buffer zone on both sides of the stream measured from top of streambank.

Construction Methods

(A) Clearing and Grubbing

In areas identified as High Quality Water Zones/Environmentally Sensitive Areas, the Contractor may perform clearing operations, but not grubbing operations until immediately prior to beginning grading operations as described in Article 200-1 of the *Standard Specifications*. Only clearing operations (not grubbing) shall be allowed in this buffer zone until immediately prior to beginning grading operations. Erosion control devices shall be installed immediately following the clearing operation.

(B) Grading

Once grading operations begin in identified High Quality Water Zones/ Environmentally Sensitive Areas, work shall progress in a continuous manner until complete. All construction within these areas shall progress in a continuous manner such that each phase is complete and areas are permanently stabilized prior to beginning of next phase. Failure on the part of the Contractor to complete any phase of construction in a continuous manner in High Quality Water Zones/ Environmentally Sensitive Areas will be just cause for the

Engineer to direct the suspension of work in accordance with Article 108-7 of the *Standard Specifications*.

(C) Temporary Stream Crossings

Any crossing of streams within the limits of this project shall be accomplished in accordance with the requirements of Subarticle 107-12 of the *Standard Specifications*.

(D) Seeding and Mulching

Seeding and mulching shall be performed in accordance with Section 1660 of the *Standard Specifications* and vegetative cover sufficient to restrain erosion shall be installed immediately following grade establishment.

Seeding and mulching shall be performed on the areas disturbed by construction immediately following final grade establishment. No appreciable time shall lapse into the contract time without stabilization of slopes, ditches and other areas within the High Quality Water Zones/Environmentally Sensitive Areas.

(E) Stage Seeding

The work covered by this section shall consist of the establishment of a vegetative cover on cut and fill slopes as grading progresses. Seeding and mulching shall be done in stages on cut and fill slopes that are greater than 20 feet in height measured along the slope, or greater than 2 acres in area. Each stage shall not exceed the limits stated above.

Additional payments will not be made for the requirements of this section, as the cost for this work shall be included in the contract unit prices for the work involved.

MINIMIZE REMOVAL OF VEGETATION:

The Contractor shall minimize removal of vegetation within project limits to the maximum extent practicable. Vegetation along stream banks and adjacent to other jurisdictional resources outside the construction limits shall only be removed upon approval of Engineer. No additional payment will be made for this minimization work.

STOCKPILE AREAS:

The Contractor shall install and maintain erosion control devices sufficient to contain sediment around any erodible material stockpile areas as directed.

ACCESS AND HAUL ROADS:

At the end of each working day, the Contractor shall install or re-establish temporary diversions or earth berms across access/haul roads to direct runoff into sediment devices. Silt fence sections

that are temporarily removed shall be reinstalled across access/haul roads at the end of each working day.

WASTE AND BORROW SOURCES:

Payment for temporary erosion control measures, except those made necessary by the Contractor's own negligence or for his own convenience, will be paid for at the appropriate contract unit price for the devices or measures utilized in borrow sources and waste areas.

No additional payment will be made for erosion control devices or permanent seeding and mulching in any commercial borrow or waste pit. All erosion and sediment control practices that may be required on a commercial borrow or waste site will be done at the Contractor's expense.

All offsite Staging Areas, Borrow and Waste sites shall be in accordance with "Borrow and Waste Site Reclamation Procedures for Contracted Projects" located at:

http://www.ncdot.gov/doh/operations/dp_chief_eng/roadside/fieldops/downloads/Files/ContractorReclamationProcedures.pdf

All forms and documents referenced in the "Borrow and Waste Site Reclamation Procedures for Contracted Projects" shall be included with the reclamation plans for offsite staging areas, and borrow and waste sites.

TEMPORARY DIVERSION:

This work consists of installation, maintenance, and cleanout of *Temporary Diversions* in accordance with Section 1630 of the *Standard Specifications*. The quantity of excavation for installation and cleanout will be measured and paid for as *Silt Excavation* in accordance with Article 1630-3 of the *Standard Specifications*.

CLEAN WATER DIVERSION:

Description

This work consists of installing, maintaining, and removing any and all material required for the construction of clean water diversions. The clean water diversions shall be used to direct water flowing from offsite around/away from specific area(s) of construction.

Materials

Refer to Division 10

Item

Geotextile for Soil Stabilization, Type 4

Section

1056

Construction Methods

The Contractor shall install the clean water diversions in accordance with the details in the plans and at locations indicated in the plans, and as directed. Upon installation, the excavated material shall be immediately stabilized as provided in Section 1620 of the *Standard Specifications*. Other stabilization methods may be utilized with prior approval from the Engineer.

Line clean water diversion with geotextile unrolled in the direction of flow and lay smoothly but loosely on soil surface without creases. Bury top of slope geotextile edge in a trench at least 5" deep and tamp securely. Make vertical overlaps a minimum of 18" with upstream geotextile overlapping the downstream geotextile.

Secure geotextile with eleven gauge wire staples shaped into a *u* shape with a length of not less than 6" and a throat not less than 1" in width. Place staples along outer edges and throughout the geotextile a maximum of 3 ft. horizontally and vertically.

Measurement and Payment

Silt Excavation will be measured and paid for in accordance with Article 1630-4 of the *Standard Specifications*.

Geotextile for Soil Stabilization will be measured and paid for in accordance with Article 270-4 of the *Standard Specifications*.

Stabilization of the excavated material will be paid for as *Temporary Seeding* as provided in Section 1620 of the *Standard Specifications*.

Such price and payment shall be considered full compensation for all work covered by this section including all materials, construction, maintenance, and removal of the clean water diversions.

SAFETY FENCE AND JURISDICTIONAL FLAGGING:

Description

Safety Fence shall consist of furnishing materials, installing and maintaining polyethylene or polypropylene fence along the outside riparian buffer, wetland, or water boundary, or other boundaries located within the construction corridor to mark the areas that have been approved to infringe within the buffer, wetland, endangered vegetation, culturally sensitive areas or water. The fence shall be installed prior to any land disturbing activities.

Interior boundaries for jurisdictional areas noted above shall be delineated by stakes and highly visible flagging.

Jurisdictional boundaries at staging areas, waste sites, or borrow pits, whether considered outside or interior boundaries shall be delineated by stakes and highly visible flagging.

Materials

(A) Safety Fencing

Polyethylene or polypropylene fence shall be a highly visible preconstructed safety fence approved by the Engineer. The fence material shall have an ultraviolet coating.

Either wood posts or steel posts may be used. Wood posts shall be hardwood with a wedge or pencil tip at one end, and shall be at least 5 ft. in length with a minimum nominal 2" x 2" cross section. Steel posts shall be at least 5 ft. in length, and have a minimum weight of 0.85 lb/ft of length.

(B) Boundary Flagging

Wooden stakes shall be 4 feet in length with a minimum nominal 3/4" x 1-3/4" cross section. The flagging shall be at least 1" in width. The flagging material shall be vinyl and shall be orange in color and highly visible.

Construction Methods

No additional clearing and grubbing is anticipated for the installation of this fence. The fence shall be erected to conform to the general contour of the ground.

(A) Safety Fencing

Posts shall be set at a maximum spacing of 10 ft., maintained in a vertical position and hand set or set with a post driver. Posts shall be installed a minimum of 2 ft. into the ground. If hand set, all backfill material shall be thoroughly tamped. Wood posts may be sharpened to a dull point if power driven. Posts damaged by power driving shall be removed and replaced prior to final acceptance. The tops of all wood posts shall be cut at a 30-degree angle. The wood posts may, at the option of the Contractor, be cut at this angle either before or after the posts are erected.

The fence geotextile shall be attached to the wood posts with one 2" galvanized wire staple across each cable or to the steel posts with wire or other acceptable means.

Place construction stakes to establish the location of the safety fence in accordance with Article 105-9 or Article 801-1 of the *Standard Specifications*. No direct pay will be made for the staking of the safety fence. All stakeouts for safety fence shall be considered incidental to the work being paid for as "Construction Surveying", except that where there is no pay item for construction surveying, all safety fence stakeout will be performed by state forces.

The Contractor shall be required to maintain the safety fence in a satisfactory condition for the duration of the project as determined by the Engineer.

(B) Boundary Flagging

Boundary flagging delineation of interior boundaries shall consist of wooden stakes on 25 feet maximum intervals with highly visible orange flagging attached. Stakes shall be installed a minimum of 6” into the ground. Interior boundaries may be staked on a tangent that runs parallel to buffer but must not encroach on the buffer at any location. Interior boundaries of hand clearing shall be identified with a different colored flagging to distinguish it from mechanized clearing.

Boundary flagging delineation of interior boundaries will be placed in accordance with Article 105-9 or Article 801-1 of the *Standard Specifications*. No direct pay will be made for delineation of the interior boundaries. This delineation will be considered incidental to the work being paid for as *Construction Surveying*, except that where there is no pay item or construction surveying the cost of boundary flagging delineation shall be included in the unit prices bid for the various items in the contract. Installation for delineation of all jurisdictional boundaries at staging areas, waste sites, or borrow pits shall consist of wooden stakes on 25 feet maximum intervals with highly visible orange flagging attached. Stakes shall be installed a minimum of 6” into the ground. Additional flagging may be placed on overhanging vegetation to enhance visibility but does not substitute for installation of stakes.

Installation of boundary flagging for delineation of all jurisdictional boundaries at staging areas, waste sites, or borrow pits shall be performed in accordance with Subarticle 230-4(B)(5) or Subarticle 802-2(F) of the *Standard Specifications*. No direct pay will be made for this delineation, as the cost of same shall be included in the unit prices bid for the various items in the contract.

The Contractor shall be required to maintain alternative stakes and highly visible flagging in a satisfactory condition for the duration of the project as determined by the Engineer.

Measurement and Payment

Safety Fence will be measured and paid as the actual number of linear feet of polyethylene or polypropylene fence installed in place and accepted. Such payment will be full compensation including but not limited to furnishing and installing fence geotextile with necessary posts and post bracing, staples, tie wires, tools, equipment and incidentals necessary to complete this work.

Payment will be made under:

Pay Item
Safety Fence

Pay Unit
Linear Foot

PERMANENT SOIL REINFORCEMENT MAT:**Description**

This work consists of furnishing and placing *Permanent Soil Reinforcement Mat*, of the type specified, over previously prepared areas as directed.

Materials

The product shall be a permanent erosion control reinforcement mat and shall be constructed of synthetic or a combination of coconut and synthetic fibers evenly distributed throughout the mat between a bottom UV stabilized netting and a heavy duty UV stabilized top net. The matting shall be stitched together with UV stabilized polypropylene thread to form a permanent three-dimensional structure. The mat shall have the following minimum physical properties:

| Property | Test Method | Value | Unit |
|--|------------------------|-------|--------------------|
| Light Penetration | ASTM D6567 | 9 | % |
| Thickness | ASTM D6525 | 0.40 | in |
| Mass Per Unit Area | ASTM D6566 | 0.55 | lb/sy |
| Tensile Strength | ASTM D6818 | 385 | lb/ft |
| Elongation (Maximum) | ASTM D6818 | 49 | % |
| Resiliency | ASTM D1777 | >70 | % |
| UV Stability * | ASTM D4355 | ≥80 | % |
| Porosity (Permanent Net) | ECTC Guidelines | ≥85 | % |
| Maximum Permissible Shear Stress (Vegetated) | Performance Bench Test | ≥8.0 | lb/ft ² |
| Maximum Allowable Velocity (Vegetated) | Performance Bench Test | ≥16.0 | ft/s |

*ASTM D1682 Tensile Strength and % strength retention of material after 1000 hours of exposure.

Submit a certification (Type 1, 2, or 3) from the manufacturer showing:

- (A) the chemical and physical properties of the mat used, and
- (B) conformance of the mat with this specification.

Construction Methods

Matting shall be installed in accordance with Subarticle 1631-3(B) of the *Standard Specifications*.

All areas to be protected with the mat shall be brought to final grade and seeded in accordance with Section 1660 of the *Standard Specifications*. The surface of the soil shall be smooth, firm, stable and free of rocks, clods, roots or other obstructions that would prevent the mat from lying in direct contact with the soil surface. Areas where the mat is to be placed will not need to be mulched.

Measurement and Payment

Permanent Soil Reinforcement Mat will be measured and paid for as the actual number of square yards measured along the surface of the ground over which Permanent Soil Reinforcement Mat is installed and accepted. Overlaps will not be included in the measurement, and will be considered as incidental to the work. Such payment shall be full compensation for furnishing and installing the mat, including overlaps, and for all required maintenance.

Payment will be made under:

| Pay Item | Pay Unit |
|----------------------------------|-----------------|
| Permanent Soil Reinforcement Mat | Square Yard |

SKIMMER BASIN WITH BAFFLES:

Description

Provide a skimmer basin to remove sediment from construction site runoff at locations shown in the erosion control plans. See the Skimmer Basin with Baffles Detail sheet provided in the erosion control plans. Work includes constructing sediment basin, installation of temporary slope drain pipe and coir fiber baffles, furnishing, installation and cleanout of skimmer, providing and placing stone pad on bottom of basin underneath skimmer device, providing and placing a geotextile spillway liner, providing coir fiber mat stabilization for the skimmer outlet, disposing of excess materials, removing temporary slope drain, coir fiber baffles, geotextile liner and skimmer device, backfilling basin area with suitable material and providing proper drainage when basin area is abandoned.

Materials

| Item | Section |
|---|----------------|
| Stone for Erosion Control, Class B | 1042 |
| Geotextile for Soil Stabilization, Type 4 | 1056 |
| Fertilizer for Temporary Seeding | 1060-2 |
| Seed for Temporary Seeding | 1060-4 |
| Seeding and Mulching | 1060-4 |
| Matting for Erosion Control | 1060-8 |
| Staples | 1060-8 |
| Coir Fiber Mat | 1060-14 |
| Temporary Slope Drain | 1622-2 |
| Coir Fiber Baffle | 1640 |

Provide appropriately sized and approved skimmer device.

Provide Schedule 40 PVC pipe with a length of 6 ft. to attach to the skimmer and the coupling connection to serve as the arm pipe. For skimmer sizes of 2.5 in. and smaller, the arm pipe diameter shall be 1.5 inches. For skimmer sizes of 3 in. and larger, refer to manufacturer recommendation.

Provide 4" diameter Schedule 40 PVC pipe to attach to coupling connection of skimmer to serve as the barrel pipe through the earthen dam.

Anchors: Staples, stakes, or reinforcement bars shall be used as anchors.

Wooden Stakes:

Provide hardwood stakes 12"- 24" long with a 2" x 2" nominal square cross section. One end of the stake must be sharpened or beveled to facilitate driving through the coir fiber mat and down into the underlying soil. The other end of the stake needs to have a 1"- 2" long head at the top with a 1"- 2" notch following to catch and secure the coir fiber mat.

Steel Reinforcement Bars:

Provide uncoated #10 steel reinforcement bars 24" nominal length. The bars shall have a 4" diameter bend at one end with a 4" straight section at the tip to catch and secure the coir fiber mat.

Staples:

Provide staples made of 0.125" diameter new steel wire formed into a *u* shape not less than 12" in length with a throat of 1" in width.

Construction Methods

Excavate basin according to the erosion control plans with basin surface free of obstructions, debris, and pockets of low-density material. Install temporary slope drain pipe and construct the primary spillway according to the Skimmer Basin with Baffles Detail sheet in the erosion control plans. Temporary slope drain pipe at inlet of basin may be replaced by geotextile as directed. Construct the coir fiber baffles according to *Roadway Standard Drawings* No. 1640.01 and Section 1640 of the *Standard Specifications*.

Install skimmer device according to manufacturer recommendations. Install 4" Schedule 40 PVC pipe into dam on the lower side of basin 1 ft. from the bottom of the basin and according to the detail, and extend the pipe so the basin will drain. Attach a 6 ft. arm pipe to the coupling connection and skimmer according to manufacturer recommendations. The coupling shall be rigid and non-buoyant and not exceed a diameter of 4" and 12" in length. Attach the rope included with the skimmer to the tee between the vent socket and the tube inlet, and the other end to a wooden stake or metal post. Clean out skimmer device when it becomes clogged with sediment and/or debris and is unable to float at the top of water in skimmer basin. Take appropriate measures to avoid ice accumulation in the skimmer device. Construct a stone pad of Class B stone directly underneath the skimmer device at bottom of basin. The pad shall be a minimum of 12" in height, and shall have a minimum cross sectional area of 4 ft. by 4 ft.

Line primary spillway with geotextile unrolled in the direction of flow and lay smoothly but loosely on soil surface without creases. Bury edges of geotextile in a trench at least 5" deep and tamp firmly. If geotextile for the primary spillway is not one continuous piece of material, make horizontal overlaps a minimum of 18" with upstream geotextile overlapping the downstream geotextile. Secure geotextile with eleven gauge wire staples shaped into a *u* shape with a length

of not less than 12" and a throat not less than 1" in width. Place staples along outer edges and throughout the geotextile a maximum of 3 ft. horizontally and vertically. Geotextile shall be placed to the bottom and across the entire width of the basin according to the Skimmer Basin with Baffles detail. Place sealant inside basin around barrel pipe on top of geotextile with a minimum width of 6 in.

At the skimmer outlet, provide a smooth soil surface free from stones, clods, or debris that will prevent contact of the coir fiber matting with the soil. Unroll the matting and apply without stretching such that it will lie smoothly but loosely on the soil surface. Wooden stakes, reinforcement bars, or staples may be used as anchors in accordance with the details in the plans and as directed. Place anchors across the matting at the ends approximately 1 ft. apart. Place anchors along the outer edges and down the center of the matting 3 ft. apart.

All bare side slope sections of the skimmer basin shall be seeded with a temporary or permanent seed mix as directed and in accordance with Articles 1620-3, 1620-4, 1620-5, 1660-4, 1660-5 and 1660-7 of the *Standard Specifications*. Straw or excelsior matting shall be installed on all bare side slope sections immediately upon the completion of seeding and in accordance with Article 1631-3 of the *Standard Specifications*.

Measurement and Payment

Silt Excavation will be measured and paid for in accordance with Article 1630-4 of the *Standard Specifications*, as calculated from the typical section throughout the length of the basin as shown on the final approved plans.

Geotextile for Soil Stabilization will be measured and paid for in accordance with Article 270-4 of the *Standard Specifications*.

Coir Fiber Baffles will be measured and paid for in accordance with Article 1640-4 of the *Standard Specifications*.

___" *Skimmer* will be measured in units of each. ___" *Skimmer* will be measured and paid for as the maximum number of each size skimmer acceptably installed and in use at any one time during the life of the project. Barrel and arm pipe, cleanout, relocation and reinstallation of ___" *Skimmer* is considered incidental to the measurement of the quantity of ___" *Skimmer* and no separate payment will be made. No separate payment shall be made if ___" *Skimmer*, barrel and/or arm pipe(s) are damaged by ice accumulation.

Coir Fiber Mat will be measured and paid for as the actual number of square yards measured along the surface of the ground over which coir fiber mat is installed and accepted.

Temporary Slope Drain will be measured and paid for in accordance with Article 1622-4 of the *Standard Specifications*.

Stone for Erosion Control, Class ___ will be measured and paid for in accordance with Article 1610-4 of the *Standard Specifications*.

Seeding and Mulching will be measured and paid for in accordance with Article 1660-8 of the *Standard Specifications*.

Seed for Temporary Seeding will be measured and paid for in accordance with Article 1620-6 of the *Standard Specifications*.

Fertilizer for Temporary Seeding will be measured and paid for in accordance with Article 1620-6 of the *Standard Specifications*.

Matting for Erosion Control will be measured and paid for in accordance with Article 1631-4 of the *Standard Specifications*.

No measurement will be made for other items or for over excavation or stockpiling.

Payment will be made under:

| Pay Item | Pay Unit |
|-----------------|-----------------|
| ___" Skimmer | Each |
| Coir Fiber Mat | Square Yard |

TIERED SKIMMER BASIN WITH BAFFLES:

Description

Provide a tiered skimmer basin to remove sediment from construction site runoff at locations shown in the erosion control plans. See the Tiered Skimmer Basin Detail sheet provided in the erosion control plans. Tiered Skimmer Basins shall be installed in areas where topography creates a large elevation difference between the inlet and outlet of a single skimmer basin. Work includes constructing sediment basins, installation of coir fiber baffles, installation of temporary slope drain pipe, furnishing, installation and cleanout of skimmer, providing and placing stone pad on bottom of basin underneath skimmer device, providing and placing geotextile spillway liners, providing coir fiber mat stabilization for the skimmer outlet, disposing of excess materials, removing temporary slope drain pipe, coir fiber baffles, geotextile liner and skimmer device, backfilling basin area with suitable material and providing proper drainage when basin area is abandoned.

Materials

| Item | Section |
|---|----------------|
| Stone for Erosion Control, Class B | 1042 |
| Geotextile for Soil Stabilization, Type 4 | 1056 |
| Fertilizer for Temporary Seeding | 1060-2 |
| Seed for Temporary Seeding | 1060-4 |
| Seeding and Mulching | 1060-4 |
| Matting for Erosion Control | 1060-8 |
| Staples | 1060-8 |
| Coir Fiber Mat | 1060-14 |

Temporary Slope Drain
Coir Fiber Baffle

1622-2
1640

Provide appropriately sized and approved skimmer device.

Provide Schedule 40 PVC pipe with a length of 6 ft. to attach to the skimmer and the coupling connection to serve as the arm pipe. For skimmer sizes of 2.5 in. and smaller, the arm pipe diameter shall be 1.5 inches. For skimmer sizes of 3 in. and larger, refer to manufacturer recommendation.

Provide 4" diameter Schedule 40 PVC pipe to attach to coupling connection of skimmer to serve as the barrel pipe through the earthen dam.

Anchors: Staples, stakes, or reinforcement bars shall be used as anchors.

Wooden Stakes:

Provide hardwood stakes 12" - 24" long with a 2" x 2" nominal square cross section. One end of the stake must be sharpened or beveled to facilitate driving through the coir fiber mat and down into the underlying soil. The other end of the stake needs to have a 1" - 2" long head at the top with a 1" - 2" notch following to catch and secure the coir fiber mat.

Steel Reinforcement Bars:

Provide uncoated #10 steel reinforcement bars 24" nominal length. The bars shall have a 4" diameter bend at one end with a 4" straight section at the tip to catch and secure the coir fiber mat.

Staples:

Provide staples made of 0.125" diameter new steel wire formed into a *u* shape not less than 12" in length with a throat of 1" in width.

Construction Methods

Excavate basins according to the erosion control plans with basin surface free of obstructions, debris, and pockets of low-density material. Install temporary slope drain pipe and construct the primary spillways according to the Tiered Skimmer Basin Detail sheet in the erosion control plans. Construct the coir fiber baffles according to *Roadway Standard Drawings* No. 1640.01 and Section 1640 of the *Standard Specifications*. Multiple upper basins, or Modified Silt Basins Type 'B' as labeled on the detail, may be required based on site conditions and as directed.

Install skimmer device according to manufacturer recommendations. Install 4" Schedule 40 PVC pipe into dam on the lower side of basin 1 ft. from the bottom of the basin and according to the detail, and extend the pipe so the basin will drain. Attach a 6 ft. arm pipe to the coupling connection and skimmer according to manufacturer recommendations. The coupling shall be rigid and non-buoyant and not exceed a diameter of 4" and 12" in length. Attach the rope included with the

skimmer to the tee between the vent socket and the tube inlet, and the other end to a wooden stake or metal post. Clean out skimmer device when it becomes clogged with sediment and/or debris and is unable to float at the top of water in skimmer basin. Take appropriate measures to avoid ice accumulation in the skimmer device. Construct a stone pad of Class B stone directly underneath the skimmer device at bottom of basin. The pad shall be a minimum of 12" in height, and shall have a minimum cross sectional area of 4 ft. by 4 ft.

Line primary spillways with geotextile unrolled in the direction of flow and lay smoothly but loosely on soil surface without creases. Bury edges of geotextile in a trench at least 5" deep and tamp firmly. If geotextile for primary spillways is not one continuous piece of material, make horizontal overlaps a minimum of 18" with upstream geotextile overlapping the downstream geotextile. Secure geotextile with eleven gauge wire staples shaped into a *u* shape with a length of not less than 12" and a throat not less than 1" in width. Place staples along outer edges and throughout the geotextile a maximum of 3 ft. horizontally and vertically. Geotextile shall be placed to the bottom and across the entire width of the basin according to the Tiered Skimmer Basin with Baffles detail.

At the skimmer outlet, provide a smooth soil surface free from stones, clods, or debris that will prevent contact of the coir fiber matting with the soil. Unroll the matting and apply without stretching such that it will lie smoothly but loosely on the soil surface. Wooden stakes, reinforcement bars, or staples may be used as anchors in accordance with the details in the plans and as directed. Place anchors across the matting at the ends approximately 1 ft. apart. Place anchors along the outer edges and down the center of the matting 3 ft. apart. Place sealant inside basin around barrel pipe on top of geotextile with a minimum width of 6 in.

All bare side slope sections of the skimmer basin shall be seeded with a temporary or permanent seed mix as directed and in accordance with Articles 1620-3, 1620-4, 1620-5, 1660-4, 1660-5 and 1660-7 of the *Standard Specifications*. Straw or excelsior matting shall be installed on all bare side slope sections immediately upon the completion of seeding and in accordance with Article 1631-3 of the *Standard Specifications*.

Measurement and Payment

Silt Excavation will be measured and paid for in accordance with Article 1630-4 of the *Standard Specifications*, as calculated from the typical section throughout the length of the basin as shown on the final approved plans.

Geotextile for Soil Stabilization will be measured and paid for in accordance with Article 270-4 of the *Standard Specifications*.

Coir Fiber Baffles will be measured and paid for in accordance with Article 1640-4 of the *Standard Specifications*.

___" *Skimmer* will be measured in units of each. ___" *Skimmer* will be measured and paid for as the maximum number of each size skimmer acceptably installed and in use at any one time during the life of the project. Barrel and arm pipe, cleanout, relocation and reinstallation of ___" *Skimmer* is

considered incidental to the measurement of the quantity of ___" *Skimmer* and no separate payment will be made. No separate payment shall be made if ___" *Skimmer*, barrel and/or arm pipe(s) are damaged by ice accumulation.

Coir Fiber Mat will be measured and paid for as the actual number of square yards measured along the surface of the ground over which coir fiber mat is installed and accepted.

Temporary Slope Drain will be measured and paid for in accordance with Article 1622-4 of the *Standard Specifications*.

Stone for Erosion Control, Class ___ will be measured and paid for in accordance with Article 1610-4 of the *Standard Specifications*.

Seeding and Mulching will be measured and paid for in accordance with Article 1660-8 of the *Standard Specifications*.

Seed for Temporary Seeding will be measured and paid for in accordance with Article 1620-6 of the *Standard Specifications*.

Fertilizer for Temporary Seeding will be measured and paid for in accordance with Article 1620-6 of the *Standard Specifications*.

Matting for Erosion Control will be measured and paid for in accordance with Article 1631-4 of the *Standard Specifications*.

No measurement will be made for other items or for over excavation or stockpiling.

Payment will be made under:

| Pay Item | Pay Unit |
|-----------------|-----------------|
| ___" Skimmer | Each |
| Coir Fiber Mat | Square Yard |

STORMWATER BASIN EROSION CONTROL:

Description

Provide a skimmer to remove sediment from construction site runoff in permanent stormwater basins at locations shown in the erosion control plans. Work includes constructing basin, installation of coir fiber baffles, furnishing, installation and cleanout of skimmer, providing and placing stone pad on bottom of basin underneath skimmer device, stabilizing side slopes of basin with matting and seed, disposing of excess materials, removing coir fiber baffles, and skimmer device.

Materials

| Item | Section |
|-----------------------------|----------------|
| Seeding and Mulching | 1060-4 |
| Matting for Erosion Control | 1060-8 |
| Staples | 1060-8 |
| Coir Fiber Baffle | 1640 |

Provide appropriately sized and approved skimmer device.

Provide Schedule 40 PVC pipe with a length of 6 ft. to attach to the skimmer and the coupling connection to serve as the arm pipe. For skimmer sizes of 2.5 in. and smaller, the arm pipe diameter shall be 1.5 inches. For skimmer sizes of 3 in. and larger, refer to manufacturer recommendation.

Provide 4" diameter Schedule 40 PVC pipe to attach to coupling connection of skimmer to serve as the barrel pipe through the earthen dam.

Construction Methods

Construct permanent stormwater basin according to the plans with basin surface free of obstructions, debris, and pockets of low-density material. Construct the coir fiber baffles according to *Roadway Standard Drawings* No. 1640.01 and Section 1640 of the *Standard Specifications*.

Install skimmer device according to manufacturer recommendations. Install the coupling connection provided with the skimmer 1 ft. from the bottom of the basin and attach to permanent stormwater drainage structure. Attach the 6 ft. arm pipe to the coupling connection and skimmer according to manufacturer recommendations. The coupling shall be rigid and non-buoyant and not exceed a diameter of 4" and 12" in length. Attach the rope included with the skimmer to the tee between the vent socket and the tube inlet, and the other end to a wooden stake or metal post. Clean out skimmer device when it becomes clogged with sediment and/or debris and is unable to float at the top of water in basin. Take appropriate measures to avoid ice accumulation in the skimmer device. Construct a stone pad of Class B stone directly underneath the skimmer device at bottom of basin. The pad shall be a minimum of 12" in height, and shall have a minimum cross sectional area of 4 ft. by 4 ft.

All bare side slope sections of the stormwater basin shall be seeded with a permanent seed mix as directed and in accordance with Articles 1660-4, 1660-5 and 1660-7 of the *Standard Specifications*. Straw or excelsior matting shall be installed on all bare side slope sections immediately upon the completion of seeding and in accordance with Article 1631-3 of the *Standard Specifications*.

Measurement and Payment

Silt Excavation will be measured and paid for in accordance with Article 1630-4 of the *Standard Specifications*, as calculated from the typical section throughout the length of the basin as shown on the final approved plans.

Coir Fiber Baffles will be measured and paid for in Accordance with Article 1640-4 of the *Standard Specifications*.

___" *Skimmer* will be measured in units of each. ___" *Skimmer* will be measured and paid for as the maximum number of each size skimmer acceptably installed and in use at any one time during the life of the project. Barrel and arm pipe, cleanout, relocation and reinstallation of ___" *Skimmer* is considered incidental to the measurement of the quantity of ___" *Skimmer* and no separate payment will be made. No separate payment shall be made if ___" *Skimmer*, barrel and/or arm pipe(s) are damaged by ice accumulation.

Stone for Erosion Control, Class ___ will be measured and paid for in accordance with Article 1610-4 of the *Standard Specifications*.

Seeding and Mulching will be measured and paid for in accordance with Article 1660-8 of the *Standard Specifications*.

Matting for Erosion Control will be measured and paid for in accordance with Article 1631-4 of the *Standard Specifications*.

No measurement will be made for other items or for over excavation or stockpiling.

Payment will be made under:

| Pay Item | Pay Unit |
|-----------------|-----------------|
| ___" Skimmer | Each |

COIR FIBER WATTLES WITH POLYACRYLAMIDE (PAM):

Description

Coir Fiber Wattles are tubular products consisting of coir fibers (coconut fibers) encased in coir fiber netting. Coir Fiber Wattles are used on slopes or channels to intercept runoff and act as a velocity break. Coir Fiber Wattles are to be placed at locations shown on the plans or as directed. Installation shall follow the detail provided in the plans and as directed. Work includes furnishing materials, installation of coir fiber wattles, matting installation, PAM application, and removing wattles.

Materials

Coir Fiber Wattle shall meet the following specifications:

| | |
|----------------------------|--------------------------------|
| 100% Coir (Coconut) Fibers | |
| Minimum Diameter | 12 in. |
| Minimum Density | 3.5 lb/ft ³ +/- 10% |
| Net Material | Coir Fiber |
| Net Openings | 2 in. x 2 in. |
| Net Strength | 90 lbs. |
| Minimum Weight | 2.6 lbs./ft. +/- 10% |

Anchors: Stakes shall be used as anchors.

Wooden Stakes:

Provide hardwood stakes a minimum of 2-ft. long with a 2 in. x 2 in. nominal square cross section. One end of the stake must be sharpened or beveled to facilitate driving down into the underlying soil.

Matting shall meet the requirements of Article 1060-8 of the *Standard Specifications*, or shall meet specifications provided elsewhere in this contract.

Provide staples made of 0.125" diameter new steel wire formed into a *u* shape not less than 12" in length with a throat of 1" in width.

Polyacrylamide (PAM) shall be applied in powder form and shall be anionic or neutrally charged. Soil samples shall be obtained in areas where the wattles will be placed, and from offsite material used to construct the roadway, and analyzed for the appropriate PAM flocculant to be utilized with each wattle. The PAM product used shall be listed on the North Carolina Department of Environment and Natural Resources (NCDENR) Division of Water Quality (DWQ) web site as an approved PAM product for use in North Carolina.

Construction Methods

Coir Fiber Wattles shall be secured to the soil by wire staples approximately every 1 linear foot and at the end of each section of wattle. A minimum of 4 stakes shall be installed on the downstream side of the wattle with a maximum spacing of 2 linear feet along the wattle, and according to the detail. Install a minimum of 2 stakes on the upstream side of the wattle according to the detail provided in the plans. Stakes shall be driven into the ground a minimum of 10 in. with no more than 2 in. projecting from the top of the wattle. Drive stakes at an angle according to the detail provided in the plans.

Only install coir fiber wattle(s) to a height in ditch so flow will not wash around wattle and scour ditch slopes and according to the detail provided in the plans and as directed. Overlap adjoining sections of wattles a minimum of 6 in.

Installation of matting shall be in accordance with the detail provided in the plans, and in accordance with Article 1631-3 of the *Standard Specifications*, or in accordance with specifications provided elsewhere in this contract.

Apply PAM over the lower center portion of the coir fiber wattle where the water is going to flow over at a rate of 2 ounces per wattle, and 1 ounce of PAM on matting on each side of the wattle. PAM applications shall be done during construction activities after every rainfall event that is equal to or exceeds 0.50 in.

The Contractor shall maintain the coir fiber wattles until the project is accepted or until the wattles are removed, and shall remove and dispose of silt accumulations at the wattles when so directed in accordance with the requirements of Section 1630 of the *Standard Specifications*.

Measurement and Payment

Coir Fiber Wattles will be measured and paid for by the actual number of linear feet of wattles which are installed and accepted. Such price and payment will be full compensation for all work covered by this section, including, but not limited to, furnishing all materials, labor, equipment and incidentals necessary to install the *Coir Fiber Wattles*.

Matting will be measured and paid for in accordance with Article 1631-4 of the *Standard Specifications*, or in accordance with specifications provided elsewhere in this contract.

Polyacrylamide(PAM) will be measured and paid for by the actual weight in pounds of PAM applied to the coir fiber wattles. Such price and payment will be full compensation for all work covered by this section, including, but not limited to, furnishing all materials, labor, equipment and incidentals necessary to apply the *Polyacrylamide(PAM)*.

Payment will be made under:

| Pay Item | Pay Unit |
|---------------------|-----------------|
| Polyacrylamide(PAM) | Pound |
| Coir Fiber Wattle | Linear Foot |

TEMPORARY ROCK SILT CHECK TYPE A WITH EXCELSIOR MATTING AND POLYACRYLAMIDE (PAM):

Description

Temporary Rock Silt Checks Type A with Excelsior Matting and Polyacrylamide (PAM) are devices utilized in temporary and permanent ditches to reduce runoff velocity and incorporate PAM into the construction runoff to increase settling of sediment particles and reduce turbidity of runoff. Temporary Rock Silt Checks Type A with Excelsior Matting and PAM are to be placed at locations shown on the plans or as directed. Installation shall follow the detail provided in the plans and as directed. Work includes furnishing materials, installation of Temporary Rock Silt

Checks Type A, matting installation, PAM application, and removing Temporary Rock Silt Checks Type A with Excelsior Matting and PAM.

Materials

Structural stone shall be class B stone that meets the requirements of Section 1042 of the *Standard Specifications* for Stone for Erosion Control, Class B.

Sediment control stone shall be #5 or #57 stone, which meets the requirements of Section 1005 of the *Standard Specifications* for these stone sizes.

Matting shall meet the requirements of Excelsior Matting in Subarticle 1060-8(B) of the *Standard Specifications*, or shall meet specifications provided elsewhere in this contract.

Polyacrylamide (PAM) shall be applied in powder form and shall be anionic or neutrally charged. Soil samples shall be obtained in areas where the Temporary Rock Silt Checks Type A with Excelsior Matting and PAM will be placed, and from offsite material used to construct the roadway, and analyzed for the appropriate PAM flocculant to be utilized with each Temporary Rock Silt Check Type A. The PAM product used shall be listed on the North Carolina Department of Environment and Natural Resources (NCDENR) Division of Water Quality (DWQ) web site as an approved PAM product for use in North Carolina.

Construction Methods

Temporary Rock Silt Checks Type A shall be installed in accordance with Subarticle 1633-3(A) of the *Standard Specifications*, Roadway Standard Drawing No. 1633.01 and the detail provided in the plans.

Installation of matting shall be in accordance with the detail provided in the plans, and anchored by placing Class B stone on top of the matting at the upper and lower ends.

Apply PAM at a rate of 4 ounces over the center portion of the Temporary Rock Silt Checks Type A and matting where the water is going to flow over. PAM applications shall be done during construction activities and after every rainfall event that is equal to or exceeds 0.50 in.

The Contractor shall maintain the Temporary Rock Silt Checks Type A with Excelsior Matting and PAM until the project is accepted or until the Temporary Rock Silt Checks Type A with Excelsior Matting and PAM are removed, and shall remove and dispose of silt accumulations at the Temporary Rock Silt Checks Type A with Excelsior Matting and PAM when so directed in accordance with the requirements of Section 1630 of the *Standard Specifications*.

Measurement and Payment

Temporary Rock Silt Checks Type A will be measured and paid for in accordance with Article 1633-5 of the *Standard Specifications*, or in accordance with specifications provided elsewhere in this contract.

Matting will be measured and paid for in accordance with Article 1631-4 of the *Standard Specifications*, or in accordance with specifications provided elsewhere in this contract.

Polyacrylamide(PAM) will be measured and paid for by the actual weight in pounds of PAM applied to the Temporary Rock Silt Checks Type A. Such price and payment will be full compensation for all work covered by this section, including, but not limited to, furnishing all materials, labor, equipment and incidentals necessary to apply the *Polyacrylamide(PAM)*.

Payment will be made under:

| Pay Item | Pay Unit |
|---------------------|-----------------|
| Polyacrylamide(PAM) | Pound |

CULVERT DIVERSION CHANNEL:

Description

This work consists of providing a *Culvert Diversion Channel* to detour the existing stream around the culvert construction site at locations shown on the plans. Work includes constructing the diversion channel, disposing of excess materials, providing and placing geotextile liner, maintaining the diversion area in an acceptable condition, removing geotextile liner, backfilling diversion channel area with suitable material, and providing proper drainage when diversion channel area is abandoned.

Materials

Refer to Division 10

| Item | Section |
|---|----------------|
| Geotextile for Soil Stabilization, Type 4 | 1056 |

Construction Methods

Grade channel according to the plans with channel surface free of obstructions, debris, and pockets of low-density material. Utilize suitable material and provide disposal area for unsuitable material.

Line channel with geotextile unrolled in the direction of flow and lay smoothly but loosely on soil surface without creases. Bury top of slope geotextile edge in a trench at least 5" deep and tamp securely. Make vertical overlaps a minimum of 18" with upstream geotextile overlapping the downstream geotextile.

Secure geotextile with eleven gauge wire staples shaped into a *u* shape with a length of not less than 6" and a throat not less than 1" in width. Place staples along outer edges and throughout the geotextile a maximum of 3 ft. horizontally and vertically.

Measurement and Payment

Culvert Diversion Channel will be measured and paid for as the actual number of cubic yards excavated, as calculated from the typical section throughout the length of the diversion channel as shown on the final approved plans.

Geotextile for Soil Stabilization will be measured and paid for in accordance with Article 270-4 of the *Standard Specifications*.

Such price and payment shall be considered full compensation for all work covered by this section including all materials, construction, maintenance, and removal of *Culvert Diversion Channel*.

Payment will be made under:

| Pay Item | Pay Unit |
|---------------------------|-----------------|
| Culvert Diversion Channel | Cubic Yard |

IMPERVIOUS DIKE:**Description**

This work consists of furnishing, installing, maintaining, and removing an *Impervious Dike* for the purpose of diverting normal stream flow around the construction site. The Contractor shall construct an impervious dike in such a manner approved by the Engineer. The impervious dike shall not permit seepage of water into the construction site or contribute to siltation of the stream. The impervious dike shall be constructed of an acceptable material in the locations noted on the plans or as directed.

Materials

Acceptable materials shall include but not be limited to sheet piles, sandbags, and/or the placement of an acceptable size stone lined with polypropylene or other impervious geotextile.

Earth material shall not be used to construct an impervious dike when it is in direct contact with the stream unless vegetation can be established before contact with the stream takes place.

Measurement and Payment

Impervious Dike will be measured and paid as the actual number of linear feet of impervious dike(s) constructed, measured in place from end to end of each separate installation that has been completed and accepted. Such price and payment will be full compensation for all work including but not limited to furnishing materials, construction, maintenance, and removal of the impervious dike.

Payment will be made under:

| Pay Item | Pay Unit |
|-----------------|-----------------|
| Impervious Dike | Linear Foot |

TEMPORARY PIPE FOR CULVERT CONSTRUCTION:

Description

This work consists of furnishing, installing, maintaining and removing any and all temporary pipe used on this project in conjunction with the culvert construction.

Construction Methods

The Contractor shall install temporary pipe in locations shown on the plans in such a manner approved by the Engineer. The temporary pipe shall provide a passageway for the stream through the work-site. The minimum size requirements will be as stated on the erosion control plans.

Measurement and Payment

___" *Temporary Pipe* will be measured and paid for at the contract unit price per linear foot of temporary pipe approved by the Engineer and measured in place from end to end. Such price and payment will be full compensation for all work covered by this section including but not limited to furnishing all materials required for installation, construction, maintenance, and removal of temporary pipe.

Payment will be made under:

| Pay Item | Pay Unit |
|---------------------|-----------------|
| ___" Temporary Pipe | Linear Foot |

PUMP AROUND OPERATION:

Description

The work covered by this section consists of furnishing, installing, maintaining and removing any and all pump around systems used on this project. The Contractor shall install a pump around system in locations as shown in the plans and in other locations approved by the Engineer. The pump around system shall provide a passageway for the stream flow around the work site.

The quantity of pump around systems may be increased, decreased, or eliminated entirely as directed. Such variations in quantity will not be considered as alterations in the details of construction or a change in the character of the work. See NCDOT *Best Management Practices for Construction and Maintenance Activities* manual for example pump around operation.

Materials

| Item | Section |
|------------------------|----------------|
| Special Stilling Basin | 1639 |

Impervious Dike shall meet the specifications as provided elsewhere in this contract.

Pumps shall be of sufficient size to divert the stream flow around the work area, as approved by the Engineer.

Construction Methods

Install *impervious dike(s)* as shown on the plans or as directed. Pump water around the work site. If the water is turbid or exposed to bare soil, pump through a *special stilling basin*. Once the work is complete in an area remove the *impervious dike(s)* and pump system, and stabilize the area.

Measurement and Payment

Impervious Dike will be measured and paid for as provided elsewhere in this contract.

Special Stilling Basin will be measured and paid for in accordance with Article 1639-4 of the *Standard Specifications*.

Payment for pumping operations shall be considered incidental to the work of installing pipes and culverts. The pumping operations shall include but not be limited to, diverting the stream flow around the work area and pumping runoff from the work area into a stilling basin, special stilling basin or other sediment control device. No additional payment will be made for furnishing materials or maintenance of the pumping operations for the installation of pipes and culverts.

The above prices and payments will be full compensation for all work covered by this section including, but not limited to furnishing all of the necessary materials, construction, maintenance and removal of the impervious dike and pump around system.

COIR FIBER MAT:**Description**

Furnish material, install and maintain coir fiber mat in locations shown on the plans or in locations as directed. Work includes providing all materials, excavating and backfilling, and placing and securing coir fiber mat with stakes, steel reinforcement bars or staples as directed.

Materials

| Item | Section |
|----------------|----------------|
| Coir Fiber Mat | 1060-14 |

Anchors: Stakes, reinforcement bars, or staples shall be used as anchors.

Wooden Stakes:

Provide hardwood stakes 12"- 24" long with a 2" x 2" nominal square cross section. One end of the stake must be sharpened or beveled to facilitate driving through the coir fiber mat and down into the underlying soil. The other end of the stake needs to have a 1"- 2" long head at the top with a 1"- 2" notch following to catch and secure the coir fiber mat.

Steel Reinforcement Bars:

Provide uncoated #10 steel reinforcement bars 24" nominal length. The bars shall have a 4" diameter bend at one end with a 4" straight section at the tip to catch and secure the coir fiber mat.

Staples:

Provide staples made of 0.125" diameter new steel wire formed into a *u* shape not less than 12" in length with a throat of 1" in width.

Construction Methods

Place the coir fiber mat immediately upon final grading. Provide a smooth soil surface free from stones, clods, or debris that will prevent the contact of the mat with the soil. Unroll the mat and apply without stretching such that it will lie smoothly but loosely on the soil surface.

For stream relocation applications, take care to preserve the required line, grade, and cross section of the area covered. Bury the top slope end of each piece of mat in a narrow trench at least 6 in. deep and tamp firmly. Where one roll of matting ends and a second roll begins, overlap the end of the upper roll over the buried end of the second roll so there is a 6 in. overlap. Construct check trenches at least 12 in. deep every 50 ft. longitudinally along the edges of the mat or as directed. Fold over and bury mat to the full depth of the trench, close and tamp firmly. Overlap mat at least 6 in. where 2 or more widths of mat are installed side by side.

Place anchors across the mat at the ends approximately 1 ft. apart. Place anchors along the outer edges and down the center of the mat 3 ft. apart.

Adjustments in the trenching or anchoring requirements to fit individual site conditions may be required.

Measurement and Payment

Coir Fiber Mat will be measured and paid for as the actual number of square yards measured along the surface of the ground over which coir fiber mat is installed and accepted.

No measurement will be made for anchor items.

Payment will be made under:

Pay Item

Coir Fiber Mat

Pay Unit

Square Yard

FLOATING TURBIDITY CURTAIN:**Description**

This work consists of furnishing a *Floating Turbidity Curtain* to deter silt suspension and movement of silt particles during construction. The floating turbidity curtain shall be constructed at locations as directed.

Materials

The curtain material shall be made of a tightly woven nylon, plastic or other non-deteriorating material meeting the following specifications:

| Property | Value |
|-------------------------|----------------------------|
| Grab tensile strength | *md-370 lbs *cd-250 lbs |
| Mullen burst strength | 480 psi |
| Trapezoid tear strength | *md-100 lbs *cd-60 lbs |
| Apparent opening size | 70 US standard sieve |
| Percent open area | 4% permittivity 0.28 sec-1 |

*md - machine direction

*cd - cross machine direction

In the event that more than one width of fabric is required, a 6" overlap of the material shall also be required.

The curtain material shall be supported by a flotation material having over 29 lbs/ft buoyancy. The floating curtain shall have a 5/16" galvanized chain as ballast and dual 5/16" galvanized wire ropes with a heavy vinyl coating as load lines.

Construction Methods

The Contractor shall maintain the *Floating Turbidity Curtain* in a satisfactory condition until its removal is requested by the Engineer. The curtain shall extend to the bottom of the jurisdictional resource. Anchor the curtain according to manufacturer recommendations.

Measurement and Payment

Floating Turbidity Curtain will be measured and paid for as the actual number of square yards of curtain furnished as specified and accepted. Such price and payment will be full compensation for

the work as described in this section including but not limited to furnishing all materials, tools, equipment, and all incidentals necessary to complete the work.

Payment will be made under:

| Pay Item | Pay Unit |
|----------------------------|-----------------|
| Floating Turbidity Curtain | Square Yard |

STREAM CHANNEL RELOCATION LIMITATIONS:

The following sequence of construction shall be followed in the areas designated on the plans as stream relocations. Failure on the part of the Contractor to follow this sequence, and complete each step prior to proceeding in this area as specified, will be just cause for the Engineer to direct the suspension of work in accordance with Article 108-7 of the *Standard Specifications*.

- (A) Clear, but do not grub area within the Environmentally Sensitive Area on the existing stream to be relocated.
- (B) Construct and stabilize, with vegetation or erosion control materials sufficient to restrain erosion, the proposed stream channel relocation as shown on the plans.
- (C) Divert water into newly constructed channel only after it has been stabilized and approved.
- (D) Begin grubbing and/or grading within the Environmentally Sensitive Area of the existing stream.

The Contractor shall perform seeding and mulching and install erosion control matting to all cut/fill slopes adjacent to stream relocations in accordance with the contract.

The above requirements apply to the stream channels being constructed at the following stations:

Approx. Sta. 93+65 to 97+05 -L-

STREAMBANK REFORESTATION:

Description

Streambank Reforestation will be planted in areas designated on the plans and as directed. See the Streambank Reforestation Detail Sheets.

The entire *Streambank Reforestation* operation shall comply with the requirements of Section 1670 of the *Standard Specifications*.

Materials

| Item | Section |
|----------------|----------------|
| Coir Fiber Mat | 1060-14 |

Live Stakes:

Type I Streambank Reforestation shall be live stakes, planted along both streambanks. Live stakes shall be ½" - 2" in diameter. Stakes shall also be 2 ft. - 3 ft. in length.

Live staking plant material shall consist of a random mix made up of 50% Black Willow (*Salix nigra*) and 50% Silky Dogwood (*Cornus amomum*). Other species may be substituted upon approval of the Engineer. All plant material shall be harvested locally (within the same physiographic ecoregion and plant hardiness zone) or purchased from a local nursery, with the approval of the Engineer. All live stakes shall be dormant at time of acquisition and planting.

Staples, stakes, or reinforcement bars shall be used as anchors and shall meet the following requirements:

Wooden Stakes:

Provide hardwood stakes 12" - 24" long with a 2" x 2" nominal square cross section. One end of the stake must be sharpened or beveled to facilitate driving through the coir fiber mat and down into the underlying soil. The other end of the stake needs to have a 1" - 2" long head at the top with a 1" - 2" notch following to catch and secure the coir fiber mat.

Steel Reinforcement Bars:

Provide uncoated #10 steel reinforcement bars 24" nominal length. The bars shall have a 4" diameter bend at one end with a 4" straight section at the tip to catch and secure the coir fiber mat.

Staples:

Provide staples made of 0.125" diameter new steel wire formed into a *u* shape not less than 12" in length with a throat of 1" in width.

Bare Root Seedlings:

Type II Streambank Reforestation shall be bare root seedlings 12"-18" tall.

Construction Methods

Coir fiber matting shall be installed on the streambanks where live staking is to be planted as shown on the Streambank Reforestation Detail Sheets and in locations as directed. Work includes providing all materials, excavating and backfilling, and placing and securing coir fiber mat.

Provide a smooth soil surface free from stones, clods, or debris that will prevent the contact of the matting with the soil. Place the matting immediately upon final grading and permanent seeding. Take care to preserve the required line, grade, and cross section of the area covered.

Unroll the matting and apply without stretching such that it will lie smoothly but loosely on the soil surface. Bury the top slope end of each piece of matting in a narrow trench at least 6" deep and tamp firmly. Where one roll of matting ends and a second roll begins, overlap the end of the upper roll over the buried end of the second roll so there is a 6" overlap. Construct check trenches at least 12" deep every 50 ft. longitudinally along the edges of the matting, or as directed. Fold over and bury matting to the full depth of the trench, close and tamp firmly. Overlap matting at least 6" where 2 or more widths of matting are installed side by side.

Wooden stakes, reinforcement bars, or staples may be used as anchors in accordance with the Streambank Reforestation Detail Sheets and as directed. Place anchors across the matting at ends, junctions, and check trenches approximately 1 ft. apart. Place anchors down the center of each strip of matting 3 ft. apart. Place anchors along all lapped edges 1 ft. apart. Refer to the Streambank Reforestation Detail Sheets for anchoring pattern. The Engineer may require adjustments in the trenching or anchoring requirements to fit individual site conditions.

During preparation of the live stakes, the basal ends shall be cleanly cut at an angle to facilitate easy insertion into the soil, while the tops shall be cut square or blunt for tamping. All limbs shall be removed from the sides of the live cutting prior to installation.

Live stakes shall be installed within 48 hours of cutting. Outside storage locations should be continually shaded and protected from wind and direct sunlight. Live cut plant material shall remain moist at all times before planting.

Stakes shall be spaced approximately 4 ft. on center. Live stakes shall be installed according to the configuration presented on the Streambank Reforestation Detail Sheets.

Tamp live stakes perpendicularly into the finished bank slope with a dead blow hammer, with buds oriented in an upward direction. Stakes should be tamped until approximately $\frac{3}{4}$ of the stake length is within the ground. The area around each live stake shall be compacted by foot after the live stake has been installed.

1"- 2" shall be cut cleanly off of the top of each live stake with loppers at an angle of approximately 15 degrees following installation. Any stakes that are split or damaged during installation shall be removed and replaced.

The bare root seedlings shall be planted as soon as practical following permanent *Seeding and Mulching*. The seedlings shall be planted from top of bank out, along both sides of the stream, as designated on the plans.

Root dip: The roots of reforestation seedlings shall be coated with a slurry of water, and either a fine clay (kaolin) or a superabsorbent that is designated as a bare root dip. The type, mixture ratio, method of application, and the time of application shall be submitted to the Engineer for approval.

With the approval of the Engineer, seedlings may be coated before delivery to the job or at the time of planting, but at no time shall the roots of the seedlings be allowed to dry out. The roots shall be moistened immediately prior to planting.

Seasonal Limitations: Streambank reforestation shall be planted from November 15 through March 15.

Measurement and Payment

Streambank Reforestation will be measured and paid for as the actual number of acres of land measured along the surface of the ground, which has been acceptably planted in accordance with this section.

Payment will be made under:

| Pay Item | Pay Unit |
|--------------------------|-----------------|
| Streambank Reforestation | Acre |

CONCRETE WASHOUT STRUCTURE:
(12-01-15)

Description

Concrete washout structures are enclosures above or below grade to contain concrete waste water and associated concrete mix from washing out ready-mix trucks, drums, pumps, or other equipment. Concrete washouts must collect and retain all the concrete washout water and solids, so that this material does not migrate to surface waters or into the ground water. These enclosures are not intended for concrete waste not associated with wash out operations.

The concrete washout structure may include constructed devices above or below ground and or commercially available devices designed specifically to capture concrete waste water.

Materials

| Item | Section |
|----------------------|----------------|
| Temporary Silt Fence | 1605 |

Safety Fence shall meet the specifications as provided elsewhere in this contract.

Geomembrane basin liner shall meet the following minimum physical properties for low permeability; it shall consist of a polypropylene or polyethylene 10 mil thick geomembrane. If the minimum setback dimensions can be achieved the liner is not required. (5 feet above groundwater, 50 feet from top of bank of perennial stream, other surface water body, or wetland.)

Construction Methods

Build an enclosed earthen berm or excavate to form an enclosure in accordance with the details and as directed.

Install temporary silt fence around the perimeter of the enclosure in accordance with the details and as directed if structure is not located in an area where existing erosion and sedimentation control devices are capable to containing any loss of sediment.

Post a sign with the words “Concrete Washout” in close proximity of the concrete washout area, so it is clearly visible to site personnel.

The construction details for the above grade and below grade concrete washout structures can be found on the following web page link:

http://www.ncdot.gov/doh/operations/dp_chief_eng/roadside/soil_water/details/

[Alternate details for accommodating concrete washout may be submitted for review and approval.](#)

[The alternate details shall include the method used to retain and dispose of the concrete waste water within the project limits and in accordance with the minimum setback requirements.](#) (5 feet above groundwater, 50 feet from top of bank of perennial stream, other surface water body, or wetland.)

Maintenance and Removal

Maintain the concrete washout structure(s) to provide adequate holding capacity plus a minimum freeboard of 12 inches. Remove and dispose of hardened concrete and return the structure to a functional condition after reaching 75% capacity.

Inspect concrete washout structures for damage and maintain for effectiveness.

Remove the concrete washout structures and sign upon project completion. Grade the earth material to match the existing contours and permanently seed and mulch area.

Measurement and Payment

Concrete Washout Structure will be paid for per each enclosure installed in accordance with the details. If alternate details are approved then those details will also be paid for per each approved and installed device.

Temporary Silt Fence will be measured and paid for in accordance with Article 1605-5 of the *Standard Specifications*.

No measurement will be made for other items or for over excavation or stockpiling.

Payment will be made under:

| Pay Item | Pay Unit |
|----------------------------|-----------------|
| Concrete Washout Structure | Each |

U-3109A

Signals and Intelligent Transportation Systems
Project Special Provisions
(Version 12.5)

Prepared By: iou
31-Jan-17

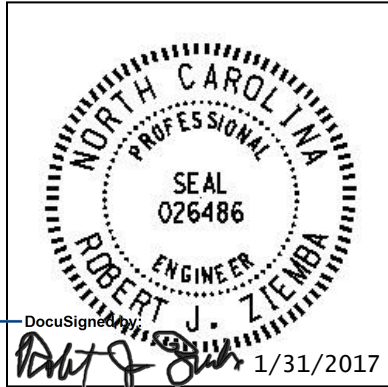

DOCUMENT NOT CONSIDERED FINAL
UNLESS ALL SIGNATURES COMPLETED

Contents

- 1. 2012 STANDARD SPECIFICATIONS FOR ROADS & STRUCTURES.....3**
 - 1.1. POLYMER CONCRETE (PC) JUNCTION BOXES (1091-5(B)).....3
 - 1.2. SUBMITTAL REQUIREMENTS (1098-1(B))3
 - 1.3. JUNCTION BOXES (1098-5).....3
 - 1.4. CONTROLLERS WITH CABINETS – MATERIAL (1751-2)3
 - 1.5. PEDESTALS (1098-14)3
 - 1.6. PEDESTALS (1743)5
- 2. SIGNAL HEADS.....6**
 - 2.1. MATERIALS6
 - A. General:.....6
 - B. Vehicle Signal Heads:.....7
 - C. Pedestrian Signal Heads:10
 - D. Signal Cable:12
- 3. VIDEO IMAGING LOOP EMULATOR DETECTOR SYSTEMS12**
 - 3.1. DESCRIPTION12
 - 3.2. MATERIALS12
 - A. General:.....12
 - B. Loop Emulator System:.....14
 - C. Video Imaging Loop Emulator System Support:.....15
 - 3.3. CONSTRUCTION METHODS15
 - 3.4. MEASUREMENT AND PAYMENT16
- 4. MICROWAVE VEHICLE DETECTOR – SINGLE ZONE17**
 - 4.1. DESCRIPTION17
 - 4.2. MATERIALS17
 - 4.3. CONSTRUCTION METHODS17
 - 4.4. MEASUREMENT AND PAYMENT17
- 5. TRAFFIC SIGNAL SUPPORTS.....18**
 - 5.1. METAL TRAFFIC SIGNAL SUPPORTS – ALL POLES18
 - A. General:.....18
 - B. Materials:20
 - C. Construction Methods:21
 - 5.2. METAL POLE UPRIGHTS (VERTICAL MEMBERS)21
 - A. Materials:21
 - B. Construction Methods:23
 - 5.3. MAST ARMS.....23
 - A. Materials:24
 - B. Construction Methods:24
 - 5.4. DRILLED PIER FOUNDATIONS FOR METAL TRAFFIC SIGNAL POLES.....24

- A. *Description:* 25
- B. *Soil Test and Foundation Determination:* 25
- C. *Drilled Pier Construction:* 27
- 5.5. CUSTOM DESIGN OF TRAFFIC SIGNAL SUPPORTS 27
 - A. *General:* 27
 - B. *Metal Poles:* 28
 - C. *Mast Arms:* 31
- 5.6. POLE NUMBERING SYSTEM 31
- 5.7. MEASUREMENT AND PAYMENT 31
- 6. CONTROLLERS WITH CABINETS 31**
 - 6.1. MATERIALS – TYPE 2070L CONTROLLERS 31
 - 6.2. MATERIALS – GENERAL CABINETS 32
 - 6.3. MATERIALS – TYPE 170E CABINETS 33
 - A. *Type 170 E Cabinets General:* 33
 - B. *Type 170 E Cabinet Electrical Requirements:* 33
 - C. *Type 170 E Cabinet Physical Requirements:* 40
 - D. *Model 2018 Enhanced Conflict Monitor:* 42
 - 6.4. MATERIALS – TYPE 170 DETECTOR SENSOR UNITS 52
 - 6.5. MATERIALS – TYPE 2070E CONTROLLERS 52

1. 2012 STANDARD SPECIFICATIONS FOR ROADS & STRUCTURES

The 2012 Standard Specifications are revised as follows:

1.1. Polymer Concrete (PC) Junction Boxes (1091-5(B))

Page 10-202, revise paragraph starting on line 9 to read “Provide polymer concrete (PC) boxes which have bolted covers and open bottoms. Provide vertical extensions of 6" to 12" as required by project special provisions.”

Page 10-202, revise sentence beginning on line 14 to read “Other thermoplastic materials may be used for components which are not normally exposed to sunlight.”

1.2. Submittal Requirements (1098-1(B))

Page 10-208, replace paragraph on line 34 with the following:

Submit for approval catalog cuts and/or shop drawings for materials proposed for use on the project. Allow 40 days for review of each submittal. Do not fabricate or order material until receipt of Engineer’s approval.

Submit 4 copies of each catalog cut and/or drawing and show for each component the material description, brand name, stock-number, size, rating, manufacturing specification and the intended use (identified by labeling all components with the corresponding contract line item number). Present the submittals neatly arranged in the same order as the contract bid items. Electronic submittals of catalog cuts and drawings may be accepted in lieu of hard copies.

One hard copy and an electronic (PDF) copy of reviewed submittals will be returned to the Engineer from the ITS and Signals Unit.

1.3. Junction Boxes (1098-5)

Page 10-212, sub-Section 1098-5(C) Oversized Junction Boxes

Revise sentence to read, “Provide oversized junction boxes and covers with minimum inside dimensions of 28"(l) x 15"(w) x 22"(h).”

1.4. Controllers with Cabinets – Material (1751-2)

Page 17-37, Section 1751-2 Material

Add the following paragraph:

When the plans or specifications require a Type 2070L controller, contractor may provide a Type 2070E controller. Unless otherwise allowed by the Engineer, provide controllers of only one type.

1.5. Pedestals (1098-14)

Page 10-218, sub-Section 1098-14(A) Pedestal Shaft

Replace “6063-T6” with “6061-T6” in the second paragraph on line 24.

Page 10-219, sub-Section 1098-14(B) Transformer Bases

Revise paragraph 2, lines 19 to 21 to read: “Provide a minimum access opening for all transformer bases of 8”x 8” with an access door that is attached with a 1/4” x 3/4” long stainless steel vandal proof screw to secure access door.”

Add the following sentence after the second sentence of paragraph 3 on line 24: “Include a set screw prep and 3/8”-16 x 1” stainless steel set screw to secure the pedestal post to the pedestal base.”

Page 10-219-220, sub-Section 1098-14 (C) Anchor Bolts

Replace entire paragraph on page 219, line 45-49 and page 220, line 1-5 with the following paragraphs:

For each pedestal, provide four (4) anchor bolts meeting the requirements of ASTM F1554, Grade 55, of the size and length specified in *Roadway Standard Drawings* No. 1743. Provide anchor bolts with coarse threads meeting the bolt/thread criteria specified by AISC. Provide threads for a minimum length of 4" on each end of the bolt. All thread anchor rods may be used. Ensure anchor bolts are hot-dipped galvanized in accordance with ASTM A153.

For each anchor bolt:

- Provide three (3) heavy hex nuts; one at the top, and 2 at the bottom (embedded end) of the anchor bolt. Provide hex nuts with coarse threads that match the anchor bolt thread requirements above. Provide hex nuts that meet the requirements of ASTM A563 Grade DH, ASTM A194, Grade 2H or equivalent. Galvanize all heavy hex nuts in accordance with ASTM A153.
- Provide one (1) standard size washer that meets the requirements of ASTM F436 for use between the two heavy hex nuts on the embedded end of the anchor bolt. Galvanize in accordance with ASTM A153.
- Provide one (1) extra thick, oversized washer for use over the slotted opening of the pedestal base. Fabricate washer to meet the chemical, physical, and heat treating requirements of ASTM F436. Fabricate the washer to the diameter and thickness needed. Galvanize fabricated washer in accordance with ASTM A153. Heat treat to the same requirements as F436 (i.e. 26 to 45 HRC).

For a $\frac{3}{4}$ " diameter anchor bolt mounted in a $1\frac{1}{2}$ " slotted opening, the dimensional requirements for an extra thick, oversized washer are as follows:

- The minimum Outside Diameter (OD) required is $2\frac{3}{4}$ ".
- The hole Inside Diameter (ID) = Nominal Bolt Diameter + $\frac{1}{16}$ " = 0.812".
- The minimum washer thickness required is $\frac{3}{8}$ ".

If anchor bolts less than $\frac{3}{4}$ " in diameter are proposed for use to anchor pedestal bases, provide a washer calculation to ensure the washer thickness is adequate. To account for any pedestal manufacturing differences, verify the actual slotted opening width of the pedestal base anchoring points, and include it in the calculation. Anchor bolts that are less than $\frac{1}{2}$ " in diameter may not be used as they are not structurally adequate to support the pedestal and may inhibit the performance of the breakaway base.

The fabrication process for thick washers makes the washer slightly tapered (i.e. the top OD and the bottom OD are not the same). Install thick washers with the larger diameter face down against the pedestal base casting.

Do not use standard washers over the slotted opening of the pedestal base. Do not substitute or stack thin washers to achieve the required thickness specified or required.

In addition to the submittal requirements of Section 1098-1(B), provide Mill Certifications, Galvanization Certifications, and Heat Treating Certifications for all anchor bolts, fabricated washers, and structural hardware.

1.6. Pedestals (1743)

Page 17-34, Add the following new sub-Section:

1743-4 - Screw-In Helical Foundation Anchor Assembly

Description:

Furnish and install screw-in helical foundation as an alternative to the standard reinforced concrete foundation specified in Article 1743 "Pedestals" of the Standard Specifications, for supporting Type I and Type II Pedestals. Do not use for Type III Pedestals.

Materials for Type I – Pedestrian Pushbutton Post:

Fabricate pipe assembly consisting of a 4" diameter x 56" long pipe, single helical blade and square fixed attachment plate. Furnish pipe in accordance with ASTM A-53 ERW Grade B and include a 2" x 3" cable opening in the pipe at 18" below the attachment plate. Furnish steel attachment plate and helical blade in accordance with ASTM A-36. Include (4) slotted mounting holes in the attachment plate to fit bolt circles ranging from 7-3/4" to 14-3/4" diameter. Furnish additional 3/4" keyholes at slotted holes to permit anchor bolt installation and replacement from top surface. Include combination bolt-head retainer and dirt scrapers at the attachment plate underside to allow for a level or flush-mount plate installation with respect to the finished grade. Galvanize pipe assembly components in accordance with AASHTO M 111 or an approved equivalent.

Furnish (4) 3/4"-10NC x 3" square head anchor bolts to meet the requirements of ASTM 325. Provide (4) 3/4" plain flat galvanized washers, (4) 3/16" thick galvanized plate washers and (4) 3/4" galvanized hex nuts. Galvanize in accordance with AASHTO M 111 or an approved equivalent.

Construction Methods for Type I – Pedestrian Pushbutton Post:

Advance or mechanically screw foundation into soil up until top of attachment plate is level with finished grade. Slide the anchor bolt heads through the keyhole openings and under the attachment plate with threads pointing up. Bolt the pedestal base to the foundation attachment plate. For further construction methods, see manufacturer's installation drawings.

Materials for Type II – Normal-Duty Pedestal:

Fabricate pipe assembly consisting of a 6" diameter x 60" long, single helical blade, 1-1/4" diameter stinger rod and square fixed attachment plate. Furnish pipe in accordance with ASTM A-53 ERW Grade B using schedule 40 wall thickness and include a 2" x 3" cable opening in the pipe at 18" below the attachment plate. Furnish steel attachment plate, helical blade and stinger rod in accordance with ASTM A-36. Include (4) slotted mounting holes in the attachment plate to fit bolt circles ranging from 10" to 15" diameter. Furnish additional 1-1/4" keyholes at slotted holes to permit anchor bolt installation and replacement from top surface. Include combination bolt-head retainer and dirt scrapers at the attachment plate underside to allow for a level or flush-mount plate installation with respect to the finished grade. Galvanize pipe assembly components in accordance with AASHTO M 111 or an approved equivalent.

Furnish (4) 1"-8NC x 4" galvanized Grade 5 square head anchor bolts. Provide (4) 1" plain flat galvanized washers and (4) 1" galvanized hex nuts. Galvanize in accordance with AASHTO M 111 or an approved equivalent.

Construction Methods for Type II – Normal-Duty Pedestal:

Advance or mechanically screw foundation into soil up until top of attachment plate is level with finished grade. Slide the anchor bolt heads through the keyhole openings and under the attachment plate with threads pointing up. Bolt the pedestal base to the foundation attachment plate.

For further construction methods, see manufacturer's installation drawings.

Page 17-34, revise Measurement and Payment to sub-Section 1743-5.

Revise the last paragraph to read:

No measurement will be made for pedestal foundations, pedestal screw-in helical foundations, grounding systems and any peripheral pedestal mounting hardware as these are incidental to furnishing and installing pedestals.

2. SIGNAL HEADS

2.1. MATERIALS

A. General:

Fabricate vehicle signal head housings and end caps from die-cast aluminum. Fabricate 16-inch pedestrian signal head housings and end caps from die-cast aluminum. Provide visor mounting screws, door latches, and hinge pins fabricated from stainless steel. Provide interior screws, fasteners, and metal parts fabricated from stainless steel.

Fabricate tunnel and traditional visors from sheet aluminum.

Paint all surfaces inside and outside of signal housings and doors. Paint outside surfaces of tunnel and traditional visors, wire outlet bodies, wire entrance fitting brackets and end caps when supplied as components of messenger cable mounting assemblies, pole and pedestal mounting assemblies, and pedestrian pushbutton housings. Have electrostatically-applied, fused-polyester paint in highway yellow (Federal Standard 595C, Color Chip Number 13538) a minimum of 2.5 to 3.5 mils thick. Do not apply paint to the latching hardware, rigid vehicle signal head mounting brackets for mast-arm attachments, messenger cable hanger components or balance adjuster components.

Have the interior surfaces of tunnel and traditional visors painted an alkyd urea black synthetic baking enamel with a minimum gloss reflectance and meeting the requirements of MIL-E-10169, "Enamel Heat Resisting, Instrument Black."

Where required, provide polycarbonate signal heads and visors that comply with the provisions pertaining to the aluminum signal heads listed on the QPL with the following exceptions:

Fabricate signal head housings, end caps, and visors from virgin polycarbonate material. Provide UV stabilized polycarbonate plastic with a minimum thickness of 0.1 ± 0.01 inches that is highway yellow (Federal Standard 595C, Color Chip 13538). Ensure the color is incorporated into the plastic material before molding the signal head housings and end caps. Ensure the plastic formulation provides the following physical properties in the assembly (tests may be performed on separately molded specimens):

| Test | Required | Method |
|--|--------------------|------------|
| Specific Gravity | 1.17 minimum | ASTM D 792 |
| Flammability | Self-extinguishing | ASTM D 635 |
| Tensile Strength, yield, PSI | 8500 minimum | ASTM D 638 |
| Izod impact strength, ft-lb/in [notched, 1/8 inch] | 12 minimum | ASTM D 256 |

For pole mounting, provide side of pole mounting assemblies with framework and all other hardware necessary to make complete, watertight connections of the signal heads to the poles and pedestals. Fabricate the mounting assemblies and frames from aluminum with all necessary hardware, screws, washers, etc. to be stainless steel. Provide mounting fittings that match the positive locking device on the signal head with the serrations integrally cast into the brackets. Provide upper and lower pole plates that have a 1 ¼-inch vertical conduit entrance hubs with the hubs capped on the lower plate and 1 ½-inch horizontal hubs. Ensure that the assemblies provide

rigid attachments to poles and pedestals so as to allow no twisting or swaying of the signal heads. Ensure that all raceways are free of sharp edges and protrusions, and can accommodate a minimum of ten Number 14 AWG conductors.

For pedestal mounting, provide a post-top slipfitter mounting assembly that matches the positive locking device on the signal head with serrations integrally cast into the slipfitter. Provide stainless steel hardware, screws, washers, etc. Provide a minimum of six 3/8 X 3/4-inch long square head bolts for attachment to pedestal. Provide a center post for multi-way slipfitters.

For light emitting diode (LED) traffic signal modules, provide the following requirements for inclusion on the Department's Qualified Products List for traffic signal equipment.

1. Sample submittal,
2. Third-party independent laboratory testing results for each submitted module with evidence of testing and conformance with all of the Design Qualification Testing specified in section 6.4 of each of the following Institute of Transportation Engineers (ITE) specifications:
 - Vehicle Traffic Control Signal Heads – Light Emitting Diode (LED) Circular Signal Supplement
 - Vehicle Traffic Control Signal Heads – Light Emitting Diode (LED) Vehicle Arrow Traffic Signal Supplement
 - Pedestrian Traffic Control Signal Indications –Light Emitting Diode (LED) Signal Modules.

(Note: The Department currently recognizes two approved independent testing laboratories. They are Intertek ETL Semko and Light Metrics, Incorporated with Garwood Laboratories. Independent laboratory tests from other laboratories may be considered as part of the QPL submittal at the discretion of the Department,

3. Evidence of conformance with the requirements of these specifications,
4. A manufacturer's warranty statement in accordance with the required warranty, and
5. Submittal of manufacturer's design and production documentation for the model, including but not limited to, electrical schematics, electronic component values, proprietary part numbers, bill of materials, and production electrical and photometric test parameters.
6. Evidence of approval of the product to bear the Intertek ETL Verified product label for LED traffic signal modules.

In addition to meeting the performance requirements for the minimum period of 60 months, provide a written warranty against defects in materials and workmanship for the modules for a period of 60 months after installation of the modules. During the warranty period, the manufacturer must provide new replacement modules within 45 days of receipt of modules that have failed at no cost to the State. Repaired or refurbished modules may not be used to fulfill the manufacturer's warranty obligations. Provide manufacturer's warranty documentation to the Department during evaluation of product for inclusion on Qualified Products List (QPL).

B. Vehicle Signal Heads:

Comply with the ITE standard "Vehicle Traffic Control Signal Heads". Provide housings with provisions for attaching backplates.

Provide visors that are 10 inches in length for 12-inch vehicle signal heads.

Provide a termination block with one empty terminal for field wiring for each indication plus one empty terminal for the neutral conductor. Have all signal sections wired to the termination block. Provide barriers between the terminals that have terminal screws with a minimum Number 8 thread size and that will accommodate and secure spade lugs sized for a Number 10 terminal screw.

Mount termination blocks in the yellow signal head sections on all in-line vehicle signal heads. Mount the termination block in the red section on five-section vehicle signal heads.

Furnish vehicle signal head interconnecting brackets. Provide one-piece aluminum brackets less than 4.5 inches in height and with no threaded pipe connections. Provide hand holes on the bottom of the brackets to aid in installing wires to the signal heads. Lower brackets that carry no wires and are used only for connecting the bottom signal sections together may be flat in construction.

For messenger cable mounting, provide messenger cable hangers, wire outlet bodies, balance adjusters, bottom caps, wire entrance fitting brackets, and all other hardware necessary to make complete, watertight connections of the vehicle signal heads to the messenger cable. Fabricate messenger cable hanger components, wire outlet bodies and balance adjuster components from stainless steel or malleable iron galvanized in accordance with ASTM A153 (Class A) or ASTM A123. Provide serrated rings made of aluminum. Provide messenger cable hangers with U-bolt clamps. Fabricate washers, screws, hex-head bolts and associated nuts, clevis pins, cotter pins, U-bolt clamps and nuts from stainless steel.

For mast-arm mounting, provide rigid vehicle signal head mounting brackets and all other hardware necessary to make complete, watertight connections of the vehicle signal heads to the mast arms and to provide a means for vertically adjusting the vehicle signal heads to proper alignment. Fabricate the mounting assemblies from aluminum, and provide serrated rings made of aluminum. Provide stainless steel cable attachment assemblies to secure the brackets to the mast arms. Ensure all fastening hardware and fasteners are fabricated from stainless steel.

Provide LED vehicular traffic signal modules (hereafter referred to as modules) that consist of an assembly that uses LEDs as the light source in lieu of an incandescent lamp for use in traffic signal sections. Use LEDs that are aluminum indium gallium phosphorus (AlInGaP) technology for red and yellow indications and indium gallium nitride (InGaN) for green indications. Install the ultra bright type LEDs that are rated for 100,000 hours of continuous operation from -40°F to +165°F. Design modules to have a minimum useful life of 60 months and to meet all parameters of this specification during this period of useful life.

For the modules, provide spade terminals crimped to the lead wires and sized for a #10 screw connection to the existing terminal block in a standard signal head. Do not provide other types of crimped terminals with a spade adapter.

Ensure the power supply is integral to the module assembly. On the back of the module, permanently mark the date of manufacture (month & year) or some other method of identifying date of manufacture.

Tint the red, yellow and green lenses to correspond with the wavelength (chromaticity) of the LED. Transparent tinting films are unacceptable. Provide a lens that is integral to the unit with a smooth outer surface.

1. LED Circular Signal Modules:

Provide modules in the following configurations: 12-inch circular sections. All makes and models of LED modules purchased for use on the State Highway System shall appear on the current NCDOT Traffic Signal Qualified Products List (QPL).

Provide the manufacturer's model number and the product number (assigned by the Department) for each module that appears on the 2012 or most recent Qualified Products List. In addition, provide manufacturer's certification in accordance with Article 106-3 of the *Standard Specifications*, that each module meets or exceeds the ITE "Vehicle Traffic Control Signal Heads – Light Emitting Diode (LED) Circular Signal Supplement" dated June 27, 2005 (hereafter referred to as VTCSH Circular Supplement) and other requirements stated in this specification.

Provide modules that meet the following requirements when tested under the procedures outlined in the VTCSH Circular Supplement:

| Module Type | Max. Wattage at 165° F | Nominal Wattage at 77° F |
|------------------------|------------------------|--------------------------|
| 12-inch red circular | 17 | 11 |
| 12-inch green circular | 15 | 15 |

For yellow circular signal modules, provide modules tested under the procedures outlined in the VTCSH Circular Supplement to insure power required at 77° F is 22 Watts or less for the 12-inch circular module.

Note: Use a wattmeter having an accuracy of $\pm 1\%$ to measure the nominal wattage and maximum wattage of a circular traffic signal module. Power may also be derived from voltage, current and power factor measurements.

2. LED Arrow Signal Modules

Provide 12-inch omnidirectional arrow signal modules. All makes and models of LED modules purchased for use on the State Highway System shall appear on the current NCDOT Traffic Signal Qualified Products List (QPL).

Provide the manufacturer's model number and the product number (assigned by the Department) for each module that appears on the 2012 or most recent Qualified Products List. In addition, provide manufacturer's certification in accordance with Article 106-3 of the *Standard Specifications*, that each module meets or exceeds the requirements for 12-inch omnidirectional modules specified in the ITE "Vehicle Traffic Control Signal Heads – Light Emitting Diode (LED) Vehicle Arrow Traffic Signal Supplement" dated July 1, 2007 (hereafter referred to as VTCSH Arrow Supplement) and other requirements stated in this specification.

Provide modules that meet the following requirements when tested under the procedures outlined in the VTCSH Arrow Supplement:

| Module Type | Max. Wattage at 165° F | Nominal Wattage at 77° F |
|---------------------|------------------------|--------------------------|
| 12-inch red arrow | 12 | 9 |
| 12-inch green arrow | 11 | 11 |

For yellow arrow signal modules, provide modules tested under the procedures outlined in the VTCSH Arrow Supplement to insure power required at 77° F is 12 Watts or less.

Note: Use a wattmeter having an accuracy of $\pm 1\%$ to measure the nominal wattage and maximum wattage of an arrow traffic signal module. Power may also be derived from voltage, current and power factor measurements.

3. LED U-Turn Arrow Signal Modules:

Provide modules in the following configurations: 12-inch left U-Turn arrow signal modules.

Modules are not required to be listed on the ITS and Signals Qualified Products List. Provide manufacturer's certification in accordance with Article 106-3 of the *Standard Specifications*, that each module meets or exceeds the ITE "Vehicle Traffic Control Signal Heads – Light Emitting Diode (LED) Circular Signal Supplement" dated June 27, 2005 (hereafter referred to as VTCSH Circular Supplement) and other requirements stated in this specification.

Provide modules that have minimum maintained luminous intensity values that are not less than 16% of the values calculated using the method described in section 4.1 of the VTCSH Circular Supplement.

Provide modules that meet the following requirements when tested under the procedures outlined in the VTCSH Circular Supplement:

| Module Type | Max. Wattage at 165° F | Nominal Wattage at 77° F |
|----------------------------|------------------------|--------------------------|
| 12-inch Red U-Turn arrow | 17 | 11 |
| 12-inch Green U-Turn arrow | 15 | 15 |

For yellow U-Turn arrow signal modules, provide modules tested under the procedures outlined in the VTCSH Circular Supplement to ensure power required at 77° F is 22 Watts or less.

Note: Use a wattmeter having an accuracy of $\pm 1\%$ to measure the nominal wattage and maximum wattage of a circular traffic signal module. Power may also be derived from voltage, current and power factor measurements.

C. Pedestrian Signal Heads:

Provide pedestrian signal heads with international symbols that meet the MUTCD. Do not provide letter indications.

Comply with the ITE standard for "Pedestrian Traffic Control Signal Indications" and the following sections of the ITE standard for "Vehicle Traffic Control Signal Heads" in effect on the date of advertisement:

- Section 3.00 - "Physical and Mechanical Requirements"
- Section 4.01 - "Housing, Door, and Visor: General"
- Section 4.04 - "Housing, Door, and Visor: Materials and Fabrication"
- Section 7.00 - "Exterior Finish"

Provide a double-row termination block with three empty terminals and number 10 screws for field wiring. Provide barriers between the terminals that accommodate a spade lug sized for number 10 terminal screws. Mount the termination block in the hand section. Wire all signal sections to the terminal block.

Where required by the plans, provide 16-inch pedestrian signal heads with traditional three-sided, rectangular visors, 6 inches long.

Provide 2-inch diameter pedestrian push-buttons with weather-tight housings fabricated from die-cast aluminum and threading in compliance with the NEC for rigid metal conduit. Provide a weep hole in the housing bottom and ensure that the unit is vandal resistant.

Provide push-button housings that are suitable for mounting on flat or curved surfaces and that will accept 1/2-inch conduit installed in the top. Provide units that have a heavy duty push-button assembly with a sturdy, momentary, normally-open switch. Have contacts that are electrically insulated from the housing and push-button. Ensure that the push-buttons are rated for a minimum of 5 mA at 24 volts DC and 250 mA at 12 volts AC.

Provide standard R10-3 signs with mounting hardware that comply with the MUTCD in effect on the date of advertisement. Provide R10-3E signs for countdown pedestrian heads.

Design the LED pedestrian traffic signal modules (hereafter referred to as modules) for installation into standard pedestrian traffic signal sections that do not contain the incandescent signal section reflector, lens, eggcrate visor, gasket, or socket. Provide modules that consist of an assembly that uses LEDs as the light source in lieu of an incandescent lamp. Use LEDs that are of the latest aluminum indium gallium phosphorus (AlInGaP) technology for the Portland Orange hand and countdown displays. Use LEDs that are of the latest indium gallium nitride (InGaN) technology for the Lunar White walking man displays. Install the ultra-bright type LEDs that are rated for 100,000 hours of continuous operation from -40°F to +165°F. Design modules to have a minimum useful life of 60 months and to meet all parameters of this specification during this period of useful life.

Design all modules to operate using a standard 3 - wire field installation. Provide spade terminals crimped to the lead wires and sized for a #10 screw connection to the existing terminal block in a standard pedestrian signal housing. Do not provide other types of crimped terminals with a spade adapter.

Ensure the power supply is integral to the module assembly. On the back of the module, permanently mark the date of manufacture (month & year) or some other method of identifying date of manufacture.

Provide modules in the following configuration: 16-inch displays which have the solid hand/walking man overlay on the left and the countdown on the right. All makes and models of LED modules purchased for use on the State Highway System shall appear on the current NCDOT Traffic Signal Qualified Products List (QPL).

Provide the manufacturer’s model number and the product number (assigned by the Department) for each module that appears on the 2012 or most recent Qualified Products List. In addition, provide manufacturer’s certification in accordance with Article 106-3 of the *Standard Specifications*, that each module meets or exceeds the ITE “Pedestrian Traffic Control Signal Indicators - Light Emitting Diode (LED) Signal Modules” dated August 04, 2010 (hereafter referred to as PTCSI Pedestrian Standard) and other requirements stated in this specification.

Provide modules that meet the following requirements when tested under the procedures outlined in the PTCSI Pedestrian Standard:

| Module Type | Max. Wattage at 165° F | Nominal Wattage at 77° F |
|------------------------|------------------------|--------------------------|
| Hand Indication | 16 | 13 |
| Walking Man Indication | 12 | 9 |

| | | |
|----------------------|----|----|
| Countdown Indication | 16 | 13 |
|----------------------|----|----|

Note: Use a wattmeter having an accuracy of $\pm 1\%$ to measure the nominal wattage and maximum wattage of a circular traffic signal module. Power may also be derived from voltage, current and power factor measurements.

Provide module lens that is hard coated or otherwise made to comply with the material exposure and weathering effects requirements of the Society of Automotive Engineers (SAE) J576. Ensure all exposed components of the module are suitable for prolonged exposure to the environment, without appreciable degradation that would interfere with function or appearance.

Ensure the countdown display continuously monitors the traffic controller to automatically learn the pedestrian phase time and update for subsequent changes to the pedestrian phase time.

Ensure the countdown display begins normal operation upon the completion of the preemption sequence and no more than one pedestrian clearance cycle.

D. Signal Cable:

Furnish 16-4 and 16-7 signal cable that complies with IMSA specification 20-1 except provide the following conductor insulation colors:

- For 16-4 cable: white, yellow, red, and green
- For 16-7 cable: white, yellow, red, green, yellow with black stripe tracer, red with black stripe tracer, and green with black stripe tracer. Apply continuous stripe tracer on conductor insulation with a longitudinal or spiral pattern.

Provide a ripcord to allow the cable jacket to be opened without using a cutter. IMSA specification 19-1 will not be acceptable. Provide a cable jacket labeled with the IMSA specification number and provide conductors constructed of stranded copper.

3. VIDEO IMAGING LOOP EMULATOR DETECTOR SYSTEMS

3.1. DESCRIPTION

Design, furnish, provide training, and install video imaging loop emulator detection systems with all necessary hardware in accordance with the plans and specifications.

Unless otherwise specified in the contract, all loop emulator detection equipment will remain the property of the Department.

3.2. MATERIALS

A. General:

Material and equipment furnished under this section must be pre-approved on the Department's QPL by the date of installation except miscellaneous hardware such as cables and mounting hardware do not need to be pre-approved.

Used equipment will be acceptable provided the following conditions have been met:

- Equipment is listed on the current QPL.
- Equipment is in good working condition.
- Equipment is to remain the property of the contractor.

Ensure that software is licensed for use by the Department and by any other agency responsible for maintaining or operating the loop emulation system. Provide the Department with a license to duplicate and distribute the software as necessary for design and maintenance support.

Design and furnish video imaging loop emulator detection systems that detect vehicles at signalized intersections by processing video images and providing detection outputs to the signal controller in real time (within 112 milliseconds of vehicle arrival).

Furnish all required camera sensor units, loop emulator processor units, hardware and software packages, cabling, poles, mast arms, harnesses, camera mounting assemblies, surge protection panels, grounding systems, messenger cable and all necessary hardware. Furnish systems that allow the display of detection zones superimposed on an image of the roadway on a Department-furnished monitor or laptop computer screen. Ensure detection zones can be defined and data entered using a simple keyboard or mouse and monitor, or using a laptop PC with software.

Provide design drawings showing design details and camera sensor unit locations for review and acceptance before installation. Provide mounting height and location requirements for camera sensor units on the design based on site survey. Design video imaging loop emulator detection systems with all necessary hardware. Indicate all necessary poles, spans, mast arms, luminaire arms, cables, camera mounting assemblies and hardware to achieve the required detection zones where Department owned poles are not adequate to locate the camera sensor units. Do not design for the installation of poles in medians.

Obtain the Engineer's approval before furnishing video imaging loop emulator detection systems. The contractor is responsible for the final design of video imaging loop emulator detection systems. Review and acceptance of the designs by the Department does not relieve the contractor from the responsibility to provide fully functional systems and to ensure that the required detection zones can be provided.

Provide the ability to program each detection call (input to the controller) with the following functions:

- Full Time Delay – Delay timer is active continuously,
- Normal Delay – Delay timer is inhibited when assigned phase is green (except when used with TS 2 and 170/2070L controllers),
- Extend – Call is extended for this amount of time after vehicle leaves detection area,
- Delay Call/Extend Call – This feature uses a combination of full time delay and extend time on the same detection call. Ensure operation is as follows: Vehicle calls are received after the delay timer times out. When a call is detected, it is held until the detection area is empty and the programmed extend time expires. If another vehicle enters the detection area before the extend timer times out, the call is held and the extend time is reset. When the extend timer times out, the delay timer has to expire before another vehicle call can be received.

Provide the ability to program each detection zone as one of the following functions:

- Presence detector,
- Directional presence detector,
- Pulse detector,
- Directional pulse detector.

Ensure previously defined detector zones and configurations can be edited.

Provide each individual system with all the necessary equipment to focus and zoom the camera lenses without the need to enter the camera enclosure.

Provide systems that allow for the placement of at least 8 detection zones within the combined field of view of a single camera sensor unit. Provide a minimum of 8 detection outputs per camera.

Provide detection zones that can be overlapped. Ensure systems reliably detect vehicles when the horizontal distance from the camera sensor unit to the detection zone area is less than ten times the mounting height of the sensor. Ensure systems detect vehicles in multiple travel lanes.

Ensure systems can detect vehicle presence within a 98 to 102 percent accuracy (up to 2 percent of the vehicles missed and up to 2 percent of false detection) for clear, dry, daylight conditions, a 96 to 105 percent accuracy (up to 4 percent of the vehicles missed and up to 5 percent false detection) for dawn and dusk conditions, and a 96 percent accuracy (up to 4 percent of the vehicles missed) for night and adverse conditions (fog, snow, rain, etc.) using standard sensor optics and in the absence of occlusion.

Repair and replace all failed components within 72 hours.

The Department may conduct field-testing to ensure the accuracy of completed video imaging loop emulator detection systems.

B. Loop Emulator System:

Furnish loop emulator systems that receive and simultaneously process information from camera sensor units, and provides detector outputs to signal controllers.

Ensure systems provide the following:

- Operate in a typical roadside environment and meet the environmental specifications and are fully compatible with NEMA TS 1, NEMA TS 2, or Type 170/2070L controllers and cabinets,
- provide a “fail-safe” mode whereby failure of one or more of the camera sensor units or power failure of the loop emulator system will cause constant calls to be placed on the affected vehicle detection outputs to the signal controller,
- provide compensation for minor camera movement of up to 2 percent of the field of view at 400 feet without falsely detecting vehicles,
- process the video at a minimum rate of 30 times per second,
- provide separate wired connectors inside the controller cabinet for video recording each camera,
- provide remote video monitoring with a minimum refresh rate at 1 frame per second over a standard dial-up telephone line,
- provide remote video detection monitoring.

Furnish camera sensor units that comply with the following:

- have an output signal conforming to EIA RS-170 standard,
- have a nominal output impedance of 75 ohms,

- be immune to bright light sources, or have built in circuitry or protective devices to prevent damage to the sensor when pointed directly at strong light sources,
- be housed in a light colored environmental enclosure that is water proof and dust tight, and that conforms to NEMA-4 specifications or better,
- simultaneously monitor at least five travel lanes when placed at the proper mounting location with a zoom lens,
- have a sunshield attached to the environmental enclosure to minimize solar heating,
- meet FCC class B requirements for electromagnetic interference emissions,
- have a heater attached to the viewing window of the environmental enclosure to prevent ice and condensation in cold weather.

Where coaxial video cables and other cables are required between the camera sensor and other components located in the controller cabinet, furnish surge protection in the controller cabinet.

If furnishing coaxial communications cable comply with the following, as recommended by the approved loop emulator manufacturer:

- Number 20 AWG, solid bare copper conductor terminated with crimped-on BNC connectors (do not use BNC adapters) from the camera sensor to the signal controller cabinet.
- Number 22 AWG, stranded bare copper conductor terminated with crimped-on BNC connectors (do not use BNC adapters) from the camera sensor unit to the junction box, and within the signal controller cabinet.

Furnish power cable appropriately sized to meet the power requirements of the sensors. At a minimum, provide three conductor 120 VAC field power cable.

As determined during the site survey, furnish sensor junction boxes with nominal 6 x 10 x 6 inches dimensions at each sensor location. Provide terminal blocks and tie points for coaxial cable.

C. Video Imaging Loop Emulator System Support:

Furnish video imaging loop emulator systems with either a simple keyboard or a mouse with monitor and appropriate software, or with system software for use on department-owned laptop PCs. Ensure the system is Windows 2000 and Windows XP compatible.

Provide Windows 2000 and Windows XP compatible personal computer software, if needed, to provide remote video and video detection monitoring.

Ensure systems allow the user to edit previously defined detector configurations. When a vehicle is within a detection zone, provide for a change in color or intensity of the detection zone perimeter or other appropriate display changes on the Department-furnished monitor or laptop computer screen.

Provide cabling and interconnection hardware with 6-foot minimum length interconnection cable to interface with the system.

Provide all associated equipment manuals and documentation.

3.3. CONSTRUCTION METHODS

Arrange and conduct site surveys with the system manufacturer's representative and Department personnel to determine proper camera sensor unit selection and placement. Provide the Department

at least 3 working days notice before conducting site surveys. Upon completion of the site surveys the Department will provide revised plans reflecting the findings of the site survey.

Before beginning work at locations requiring video imaging loop emulator detection systems, furnish system software. Upon activation of detection zones, provide detector configuration files. Ensure that up-to-date detection configuration files are furnished for various detection zone configurations that may be required for construction phasing.

Place into operation loop emulator detection systems. Configure loop emulator detection systems to achieve required detection in designated zones. Have a certified manufacturer’s representative on site to supervise and assist with installation, set up, and testing of the system.

Install the necessary processing and communications equipment in the signal controller cabinet. Make all necessary modifications to install equipment, cabling harnesses, and camera sensor interface panels with surge suppression.

Perform modifications to camera sensor unit gain, sensitivity, and iris limits necessary to complete the installation.

Do not install camera sensor units on signal poles unless approved by the Engineer.

Install the necessary cables from each sensor to the signal controller cabinet along signal cabling routes. Install surge protection and terminate all cable conductors.

Relocate camera sensor units and reconfigure detection zones as necessary according to the plans for construction phases.

Provide at least 8 hours of training on the set up, operation, troubleshooting, and maintenance of the loop emulator detection system to a maximum of ten Department personnel. Arrange for training to be conducted by the manufacturer’s representative at an approved site within the Division responsible for administration of the project. Thirty days before conducting training submit a detailed course curriculum, draft manuals and materials, and resumes. Obtain approval of the submittal before conducting the training. At least one week before beginning training, provide three sets of complete documentation necessary to maintain and operate the system. Do not perform training until installation of loop emulator detection systems is complete.

3.4. MEASUREMENT AND PAYMENT

Actual number of site surveys, arranged, conducted, and accepted.

Actual number of cameras with internal loop emulator processing units furnished, installed, and accepted.

Actual number of camera sensor units relocated with detection zones reconfigured installed, and accepted.

No measurement will be made of video imaging loop emulator system support or training, power and video cables, and trenching as these items will be considered incidental to furnishing and installing video imaging loop emulator detection systems.

Payment will be made under:

| | |
|---|------|
| Site Survey | Each |
| Camera with Internal Loop Emulator Processing Unit..... | Each |
| Relocate Camera Sensor Unit | Each |

4. MICROWAVE VEHICLE DETECTOR – SINGLE ZONE

4.1. DESCRIPTION

Furnish and install a microwave vehicle detection unit and manufacturer recommended cables and hardware in accordance with the plans and specifications.

4.2. MATERIALS

Furnish material, equipment, and hardware under this section that is pre-approved on the ITS and Signals QPL.

Provide a detector for either side-fire or forward-fire configuration. Ensure the detector will detect vehicle in sunny, cloudy, rainy, snowy, and foggy weather conditions with self-tuning to auto-adjust in changing environmental conditions. Ensure the detector can operate from the voltage supplied by a NEMA and Type-170 traffic signal cabinet. Ensure the detector can provide detection calls to the traffic signal controller within a NEMA and Type-170 cabinet. Ensure the detector will put out a constant call in the event of a component failure or loss of power. Ensure the detector has an operating temperature range of -20 to 150 degrees F. Ensure a water resistant housing for the detector.

For advance pulse detection, ensure the detector senses vehicles in motion at a range of 200 feet with an operating frequency of 10.525 GHz +/- 25MHz.

For stop bar presence detection, ensure the detector outputs a constant call while a vehicle is in the detection zone. Ensure the presence detection unit can cover a detection zone as shown on the plans and has an effective range of at least 75 feet from the detector unit to the aim point on the road surface.

For units without an integrated card rack interface, provide Form C output relay contacts rated a minimum of 3A, 24VDC.

If a laptop is used to adjust detector settings, ensure that software is licensed for use by the Department and by any other agency responsible for maintaining or operating the microwave detection system. Provide the Department with a license to duplicate and distribute the software as necessary for design and maintenance support.

4.3. CONSTRUCTION METHODS

Install the microwave vehicle detector in accordance with the manufacturer’s recommendations.

Monitor and maintain the detector unit during construction to ensure microwave vehicle detector is functioning properly and aimed for the detection zone shown in the plans. Refer to Subarticle 1700-3 (D) Maintenance and Repair of Materials of the *Standard Specifications* for failure to maintain the microwave detection system.

4.4. MEASUREMENT AND PAYMENT

Actual number of microwave vehicle detector units furnished, installed, and accepted.

No measurement will be made of cables or hardware, as these will be considered incidental to furnishing and installing microwave vehicle detectors.

Payment will be made under:

Microwave Vehicle Detector – Single Zone..... Each

5. TRAFFIC SIGNAL SUPPORTS

5.1. METAL TRAFFIC SIGNAL SUPPORTS – ALL POLES

A. General:

Furnish and install metal strain poles and metal poles with mast arms, grounding systems, and all necessary hardware. The work covered by this special provision includes requirements for the design, fabrication, and installation of both standard and custom/site specifically designed metal traffic signal supports and associated foundations.

Provide metal traffic signal support systems that contain no guy assemblies, struts, or stay braces. Provide designs of completed assemblies with hardware that equals or exceeds AASHTO *Standard Specifications for Structural Supports for Highway Signs, Luminaires and Traffic Signals* 6th Edition, 2013 (hereafter called 6th Edition AASHTO), including the latest interim specifications. Provide assemblies with a round or near-round (18 sides or more) cross-section, or a multi sided cross section with no less than six sides. The sides may be straight, convex, or concave.

Pole heights shown on signal plans are estimated from available data for bid purposes. Prior to furnishing metal signal poles, use field measurements and adjusted cross-sections to determine whether pole heights are sufficient to obtain required clearances. If pole heights are not sufficient, the Contractor should immediately notify the Engineer of the required revised pole heights.

Ensure that metal signal poles permit cables to be installed inside poles and any required mast arms. For holes in the poles and arms used to accommodate cables, provide full-circumference grommets. Arm flange plate wire access holes should be deburred, non grommited, and oversized to fit around the 2” diameter grommited shaft flange plate wire access hole.

After fabrication, have steel poles, required mast arms, and all parts used in the assembly hot-dip galvanized per section 1076. Design structural assemblies with weep holes large enough and properly located to drain molten zinc during the galvanization process. Provide hot-dip galvanizing on structures that meets or exceeds ASTM Standard A-123. Provide galvanizing on hardware that meets or exceeds ASTM Standard A-153. Ensure that threaded material is brushed and retapped as necessary after galvanizing. Perform repair of damaged galvanizing that complies with the following:

Repair of GalvanizingArticle 1076-7

Standard Drawings for Metal Poles are available that supplement these project special provisions. These drawings are located on the Department’s website:

<https://connect.ncdot.gov/resources/safety/pages/ITS-Design-Resources.aspx>

Comply with article 1098-1B of the *2012 STANDARD SPECIFICATIONS FOR ROADS & STRUCTURES*, hereinafter referred to as the *Standard Specifications* for submittal requirements. Furnish shop drawings for approval. Provide the copies of detailed shop drawings for each type of structure as summarized below. Ensure that shop drawings include material specifications for each component and identify welds by type and size on the detail drawing only, not in table format. **Do not release structures for fabrication until shop drawings have been approved by NCDOT.** Provide an itemized bill of materials for all structural components and associated connecting hardware on the drawings.

Comply with article 1098-1A of the *Standard Specifications* for Qualified Products List (QPL) submittals. All shop drawings must include project location description, signal inventory number(s) and a project number or work order number on the drawings.

Summary of information required for metal pole review submittal:

| Item | Hardcopy Submittal | Electronic Submittal | Comments / Special Instructions |
|--|--------------------|----------------------|---|
| Sealed, Approved Signal Plan/Loading Diagram | 1 | 1 | All structure design information needs to reflect the latest approved signal plans |
| Custom Pole Shop Drawings | 4 sets | 1 set | Show NCDOT inventory number(s), contractor's name and relevant revision number in the title block. All drawings must have a <u>unique drawing</u> number for each project and identified for multiple pages. |
| Standard Pole Shop Drawings (from the QPL) | 4 sets | 1 set | Submit drawings on 11" x 17" format media. Show NCDOT inventory number(s), contractor's name and relevant revision number in the title block. All drawings must have a <u>unique drawing</u> number for each project and identified for multiple pages. |
| Structure Calculations | 1 set | 1 set | Not required for Standard QPL Poles |
| Standard Pole Foundation Drawings | 1 set | 1 set | Submit drawings on 11" x 17" format media. Submit a completed Standard Foundation Selection form for each pole using foundation table on Metal Pole Drawing M-8. |
| Custom Foundation Drawings | 4 sets | 1 set | Submit drawings on 11" x 17" format media. Show NCDOT inventory number(s), contractor's name and relevant revision number in the title block. All drawings must have a <u>unique drawing</u> number for each project and identified for multiple pages. If QPL Poles are used, include the corresponding QPL pole shop drawings with this submittal. |
| Foundation Calculations | 1 | 1 | Submit copies of LPILE input, output and pile tip deflection graph per Section 11.4 of this specification for each foundation. Not required for Standard QPL Poles |
| Soil Boring Logs and Report | 1 | 1 | Report should include a location plan and a soil classification report including soil capacity, water level, hammer efficiency, soil bearing pressure, soil density, etc. for each pole. |

NOTE – All shop drawings and custom foundation design drawings must be sealed by a Professional Engineer licensed in the state of North Carolina. All geotechnical information must be sealed by either a Professional Engineer or geologist licensed in the state of North Carolina. Include a title block and revision block on the shop drawings and foundation drawings showing the NCDOT inventory number.

Shop drawings and foundation drawings may be submitted together or separately for approval. However, shop drawings must be approved before foundations can be reviewed. Foundation designs will be returned without review if the associated shop drawing has not been approved. Boring reports should include the following: Engineer's summary, boring location maps, soil classification per AASHTO Classification System, hammer efficiency, and Metal Pole Standard Foundation Selection Form. Incomplete submittals will be returned without review. The Reviewer has the right to request additional analysis and copies of the calculations to expedite the approval process.

B. Materials:

Fabricate metal pole and arm shaft from coil or plate steel to meet the requirements of ASTM A 595 Grade A tubes. For structural steel shapes, plates and bars use A572 Gr 50 min or ASTM A709 Gr 50 min. Provide pole and arm shafts that are round in cross section or multisided tubular shapes and have a uniform linear taper of 0.14 in/ft. Construct shafts from one piece of single ply plate or coil so there are no circumferential weld splices. Galvanize in accordance with AASHTO M 111 or an approved equivalent.

Use the submerged arc process or other NCDOT previously approved process suitable for pole shaft and arms to continuously weld pole shafts and arm shafts along their entire length. The longitudinal seam weld will be finished flush to the outside contour of the base metal. Ensure shafts have no circumferential welds except at the lower end joining the shaft to the pole base and arm base. Use full penetration groove welds with backing ring for all tube-to-transverse-plate connections in accordance with 6th Edition AASHTO. Provide welding that conforms to Article 1072-18 of the *Standard Specifications*, except that no field welding on any part of the pole will be permitted unless approved by a qualified engineer.

Refer to Metal Pole Standard Drawing Sheets M2 through M5 for fabrication details. Fabricate anchor bases and mast arm connecting plates from plate steel meeting, as a minimum, the requirements of ASTM A572 Gr 50, AASHTO M270 Gr 50, ASTM A709 Gr50, or an approved equivalent. Conform to the applicable bolt pattern and orientation as shown on Metal Pole Standard Drawing Sheet M2.

Ensure all hardware is galvanized steel or stainless steel. The Contractor is responsible for ensuring that the designer/fabricator specifies connecting hardware and/or materials that do not create a dissimilar metal corrosive reaction.

Provide a minimum of four (4) 1-1/2" diameter high strength bolts for connection between arm plate and pole plate. Increase number of bolts to six (6) 1-1/2" diameter high strength bolts when arm lengths are greater than 50'-0" long.

Unless otherwise required by the design, ensure each anchor rod is 2" diameter and 60" length. Provide 10" minimum thread projection at the top of the rod, and 8" minimum at the bottom of the rod. Use anchor rod assembly and drilled pier foundation materials that meet the *Foundations and Anchor Rod Assemblies for Metal Poles* provision.

For each structural bolt and other steel hardware, hot dip galvanizing shall conform to the requirements of AASHTO M 232 (ASTM A 153). Ensure end caps for poles or mast arms are constructed of cast aluminum conforming to Aluminum Alloy 356.0F.

Provide a circular anchor bolt lock plate that will be secured to the anchor bolts at the embedded end with 2 washers and 2 nuts. Provide a base plate template that matches the bolt circle diameter of

the anchor bolt lock plate. Construct plates and templates from ¼” minimum thick steel with a minimum width of 4”. Galvanizing is not required for both plates.

Provide 4 heavy hex nuts and 4 flat washers for each anchor bolt. For nuts, use AASHTO M291 grade 2H, DH, or DH3 or equivalent material. For flat washers, use AASHTO M293 or equivalent material.

C. Construction Methods:

Erect signal support poles only after concrete has attained a minimum allowable compressive strength of 3000 psi. Install anchor rod assemblies in accordance with the *Foundations and Anchor Rod Assemblies for Metal Poles* provision.

For further construction methods, see construction methods for Metal Strain Pole, or Metal Pole with Mast Arm.

Connect poles to grounding electrodes and bond them to the electrical service grounding electrodes.

For holes in the poles used to accommodate cables, install grommets before wiring pole or arm. Do not cut or split grommets.

Attach the terminal compartment cover to the pole by a sturdy chain or cable. Ensure the chain or cable is long enough to permit the cover to hang clear of the compartment opening when the cover is removed, and is strong enough to prevent vandalism. Ensure the chain or cable will not interfere with service to the cables in the pole base.

Attach cap to pole with a sturdy chain or cable. Ensure the chain or cable is long enough to permit the cap to hang clear of the opening when the cap is removed.

Perform repair of damaged galvanizing that complies with the *Standard Specifications*, Article 1076-7 “Repair of Galvanizing.”

Install galvanized wire mesh around the perimeter of the base plate to cover the gap between the base plate and top of foundation for debris and pest control.

Install a ¼” thick plate for concrete foundation tag to include: concrete grade, depth, diameter, and reinforcement sizes of the installed foundation.

5.2. METAL POLE UPRIGHTS (VERTICAL MEMBERS)

A. Materials:

- Provide tapered tubular shafts and fabricated of steel conforming to ASTM A-595 Grade A or an approved equivalent.
- Hot-dip galvanize poles in accordance with AASHTO M 111 or an approved equivalent.
- Have shafts that are continuously welded for the entire length by the submerged arc process, and with exposed welds ground or rolled smooth and flush with the base metal. Provide welding that conforms to Article 1072-18 of the *Standard Specification* except that no field welding on any part of the pole will be permitted.
- Have Shafts with no circumferential welds except at the lower end joining the shaft to the base.

- Have anchor bases for steel poles fabricated from plate steel meeting as a minimum the requirements of ASTM A572 Gr 50, AASHTO M270 Gr 50, ASTM A709 Gr 50, or an approved equivalent.

Provide a grounding lug(s) in the approximate vicinity of the messenger cable clamp for bonding and grounding messenger cable. Lugs must accept #4 or #6 AWG wire to bond messenger cables to the pole in order to provide an effective ground fault circuit path. Refer to Metal Pole Standard Drawing Sheet M6 for construction details.

Have poles permanently stamped above the hand holes with the identification tag details as shown on Metal Pole Standard Drawing Sheet M2.

Provide liquid tight flexible metal conduit (Type LFMC), liquid tight flexible nonmetallic conduit (Type LFNC), high density polyethylene conduit (Type HDPE), or approved equivalent to isolate conductors feeding luminaires.

Fabricate poles from a single piece of steel or aluminum with single line seam weld with no transverse butt welds. Fabrication of two ply pole shafts is unacceptable with the exception of fluted shafts. Provide tapers for all shafts that begin at base and that have diameters which decrease uniformly at the rate of not more than 0.14 inch per foot (11.7 millimeters per meter) of length.

Provide four anchor nuts and four washers for each anchor bolt. Ensure that anchor bolts have required diameters, lengths, and positions, and will develop strengths comparable to their respective poles.

Provide a terminal compartment with cover and screws in each pole that encompasses the hand hole and contains a 12-terminal barrier type terminal block. Provide two terminal screws with a removable shorting bar between them for each termination. Furnish terminal compartment covers attached to the pole by a sturdy chain or cable approved by the Engineer. Ensure that the chain or cable is long enough to permit the cover to hang clear of the compartment opening when the cover is removed, and is strong enough to prevent vandals from being able to disconnect the cover from the pole. Ensure that the chain or cable will not interfere with service to the cables in the pole base.

Install grounding lugs that will accept #4 or #6 AWG wire to electrically bond messenger cables to the pole. Refer to Metal Pole Standard Drawing Sheet M6 for construction details.

For each pole, provide a 1/2 inch minimum thread diameter, coarse thread stud and nut for grounding which will accommodate #6 AWG ground wire. Ensure that the lug is electrically bonded to the pole and is conveniently located inside the pole at the hand hole.

Provide a removable pole cap with stainless steel attachment screws for the top of each pole. Ensure that the cap is cast aluminum conforming to Aluminum Association Alloy 356.0F. Furnish cap attached to the pole with a sturdy chain or cable approved by the Engineer. Ensure that the chain or cable is long enough to permit the cap to hang clear of the pole-top opening when the cap is removed.

When required by the plans, furnish couplings 42 inches above the bottom of the base for mounting of pedestrian pushbuttons. Provide mounting points consisting of 1-1/2 inch internally threaded half-couplings that comply with the NEC and that are mounted within the poles. Ensure that couplings are essentially flush with the outside surfaces of the poles and are installed before any required galvanizing. Provide a threaded plug in each mounting point. Ensure that the surface of the plug is essentially flush with the outer end of the mounting point when installed and has a recessed hole to accommodate a standard wrench.

1. STRAIN POLE SHAFTS

Provide 2 messenger cable (span wire) clamps and associated hardware for attachment of messenger cable. Ensure that diameter of the clamp is appropriate to its location on the pole and is appropriately designed to be adjustable from 1'-6" below the top, down to 6'-6" below the top of the pole. Do not attach more than one support cable to a messenger cable clamp.

Provide a minimum of three (3) 2 inch (50 mm) holes equipped with an associated coupling and weatherhead on the messenger cable load side of the pole to accommodate passage of signal cables from inside the pole. Provide galvanized threaded plugs for all unused couplings at pole entrance points. Refer to Metal Pole Standard Drawing Sheet M3 for fabrication details.

Ensure that allowable pole deflection does not exceed that allowed per 6th Edition AASHTO. Ensure maximum deflection at the top of the pole does not exceed 2.5 percent of the pole height.

2. MAST ARM POLE SHAFTS

Ensure that allowable pole deflection does not exceed that allowed per 6th Edition AASHTO. Ensure that maximum angular rotation of the top of the mast arm pole does not exceed 1 degree 40 minutes (1°40').

B. Construction Methods:

Install metal poles, hardware, and fittings as shown on the manufacturer's installation drawings. Install metal poles so that when the pole is fully loaded it is within 1 degree 40 minutes (1°40') of vertical. Install poles with the manufacturer's recommended "rake." Use threaded leveling nuts to establish rake if required.

5.3. MAST ARMS

Provide pole plates and associated gussets and fittings for attachment of required mast arms. As part of each mast arm attachment, provide a cable passage hole in the pole to allow passage of signal cables from the pole to the arm.

Ensure that allowable mast arm deflection does not exceed that allowed per 6th Edition AASHTO. Also when arm is fully loaded, tip of the arm shall not go below the arm attachment point with the pole for all load conditions per 6th Edition AASHTO.

Furnish all arm plates and necessary attachment hardware, including bolts and brackets.

Provide two extra bolts for each arm.

Provide grommet holes on the arms to accommodate cables for the signals.

Provide arms with weatherproof connections for attaching to the shaft of the pole.

Provide hardware that is galvanized steel, stainless steel, or corrosive-resistant aluminum.

Provide a removable end cap with stainless steel attachment screws for the end of each mast arm. Ensure that the cap is cast aluminum conforming to Aluminum Association Alloy 356.0F. Furnish cap attached to the arm with a sturdy chain or cable approved by the Engineer. Ensure that the chain or cable is long enough to permit the cap to hang clear of the arm end opening when the cap is removed.

Comply with the following for Steel Luminaire Arms:

- In addition to tapered tube, luminaire arms may be standard weight black steel pipe conforming to ASTM A 53-90a, Type E or Type S, Grade B or an approved equivalent.

- Conform to the welding requirements of the steel poles.
- After all fabricating, cutting, punching, and welding are completed, luminaire arms should be hot-dipped galvanized inside and outside.
- In accordance with the National Electrical Code (NEC) Article 230.2(E), provide identification of the electrical source provider for the luminaire feeder circuit with contact information on a permanent label located in the pole hand hole in the vicinity of the feeder circuit raceway.

A. Materials:

After all fabricating, cutting, punching, and welding are completed, hot-dip galvanize the structure in accordance with the AASHTO M 111 or an approved equivalent.

B. Construction Methods:

Install horizontal-type arms with sufficient manufactured rise to keep arm from deflecting below the arm attachment height.

Attach cap to the mast arm with a sturdy chain or cable. Ensure that the chain or cable is long enough to permit the cap to hang clear of the arm opening when the cap is removed.

For mast arm poles, use full penetration welds with back-up ring at the pole base and at the arm base connection.

5.4. DRILLED PIER FOUNDATIONS FOR METAL TRAFFIC SIGNAL POLES

Analysis procedures and formulas shall be based on AASHTO 6th Edition, latest ACI code and the *Drilled Shafts: Construction Procedures and Design Methods* FHWA-NHI-10-016 manual. Design methods based on engineering publications or research papers needs to have prior approval from NCDOT. The Department reserves the right to accept or disapprove any method used for the analysis.

Use a Factor of Safety of 1.33 for torsion and 2.0 for bending for the foundation design.

Foundation design for lateral load shall not exceed 1" lateral deflection at top of foundation.

For lateral analysis, use LPILE Plus V6.0 or later. Inputs, results and corresponding graphs are to be submitted with the design calculations.

Skin Friction is to be calculated using the α -method for cohesive soils and the β -method for cohesion-less soils (**Broms method will not be accepted**). Detailed descriptions of the " α " and " β " methods can be found in *FHWA-NHI-10-016*.

Omit first 2.5ft for cohesive soils when calculating skin friction.

When hammer efficiency is not provided, assume a value of 0.70.

Design all custom foundations to carry the maximum capacity of each metal pole. For standard case strain poles only, if a custom foundation is designed, use the actual shear, axial and moment reactions from the Standard Foundation Selection Table shown on Standard Drawing No. M8.

When poor soil conditions are encountered which could create an excessively large foundation design, consideration may be given to allowing an exemption to the maximum capacity design. The contractor must gain approval from the engineer before reducing a foundation's capacity. On projects where poor soil is known to be present, it is advisable that the contractor consider getting foundations approved before releasing poles for fabrication.

Have the contractor notify the engineer if the proposed foundation is to be installed on a slope other than 8H: 1V or flatter.

A. Description:

Furnish and install foundations for NCDOT metal poles with all necessary hardware in accordance with the plans and specifications.

Metal Pole Standards have been developed and implemented by NCDOT for use at signalized intersections in North Carolina. If the plans call for a standard pole, then a standard foundation may be selected from the plans. However, the Contractor is not required to use a standard foundation. If the Contractor chooses to design a non-standard site-specific foundation for a standard pole or if the plans call for a non-standard site-specific pole, design the foundation to conform to the applicable provisions in the NCDOT Metal Pole Standard Drawings and Section B7 (Non-Standard Foundation Design) below. If non-standard site specific foundations are designed for standard QPL approved strain poles, the foundation designer must use the design moment specified by load case on Metal Pole Standard Drawing Sheet M8. Failure to conform to this requirement will be grounds for rejection of the design.

If the Contractor chooses to design a non-standard foundation for a standard pole and the soil test results indicate a standard foundation is feasible for the site, the Contractor will be paid the cost of the standard foundation (drilled pier and wing wall, if applicable). Any additional costs associated with a non-standard site-specific foundation including additional materials, labor and equipment will be considered incidental to the cost of the standard foundation. All costs for the non-standard foundation design will also be considered incidental to the cost of the standard foundation.

B. Soil Test and Foundation Determination:

1. General:

Drilled piers are reinforced concrete sections, cast-in-place against in situ, undisturbed material. Drilled piers are of straight shaft type and vertical.

Some standard drilled piers for supporting poles with mast arms may require wing walls to resist torsional rotation. Based upon this provision and the results of the required soil test, a drilled pier length and wing wall requirement may be determined and constructed in accordance with the plans.

For non-standard site-specific poles, the contractor-selected pole fabricator will determine if the addition of wing walls is necessary for the supporting foundations.

2. Soil Test:

Perform a soil test at each proposed metal pole location. Complete all required fill placement and excavation at each signal pole location to finished grade before drilling each boring. Soil tests performed that are not in compliance with this requirement may be rejected and will not be paid. Drill one boring to a depth of 26 feet within a 25 foot radius of each proposed foundation.

Perform standard penetration tests (SPT) in accordance with ASTM D 1586 at depths of 1, 2.5, 5, 7.5, 10, 15, 20 and 26 feet. Discontinue the boring if one of the following occurs:

- A total of 100 blows have been applied in any 2 consecutive 6-in. intervals.
- A total of 50 blows have been applied with < 3-in. penetration.

Describe each intersection as the “Intersection of (*Route or SR #*), (*Street Name*) and (*Route or SR #*), (*Street Name*), _____ County, Signal Inventory No. _____”. Label borings with “B- *N, S, E, W, NE, NW, SE or SW*” corresponding to the quadrant location within the intersection. Pole numbers should be made available to the Drill Contractor. Include pole numbers in the boring label if they are available. If they are not available, ensure the boring labels can be cross-referenced to corresponding pole numbers. For each boring, submit a legible (hand written or typed) boring log signed and sealed by a licensed Geologist or Professional Engineer registered in North Carolina. Include on each boring the SPT blow counts and N-values at each depth, depth of the boring, hammer efficiency, depth of water table and a general description of the soil types encountered using the AASHTO Classification System.

3. Standard Foundation Determination:

Use the following method for determining the Design N-value:

$$N_{AVG} = \frac{(N@1' + N@2.5' + \dots + N@Deepest\ Boring\ Depth)}{\text{Total Number of N-values}}$$

$$Y = (N@1')^2 + (N@2.5')^2 + \dots + (N@Deepest\ Boring\ Depth)^2$$

$$Z = (N@1' + N@2.5' + \dots + N@Deepest\ Boring\ Depth)$$

$$N_{STD\ DEV} = \left\{ \frac{(\text{Total Number of N-values} \times Y) - Z^2}{(\text{Total Number of N-values}) \times (\text{Total Number of N-values} - 1)} \right\}^{0.5}$$

Design N-value equals lesser of the following two conditions:

$$N_{AVG} - (N_{STD\ DEV} \times 0.45)$$

Or

$$\text{Average of First Four N-Values} = \frac{(N@1' + N@2.5' + N@5' + N@7.5')}{4}$$

Note: If less than 4 N-values are obtained because of criteria listed in Section 2 above, use average of N-values collected for second condition. Do not include the N-value at the deepest boring depth for above calculations if the boring is discontinued at or before the required boring depth because of criteria listed in Section 2 above. Use N-value of zero for weight of hammer or weight of rod. If N-value is greater than 50, reduce N-value to 50 for calculations.

If standard NCDOT strain poles are shown on the plans and the Contractor chooses to use standard foundations, determine a drilled pier length, “L,” for each signal pole from the Standard Foundations Chart (sheet M 8) based on the Design N-value and the predominant soil type. For each standard pole location, submit a completed “Metal Pole Standard Foundation Selection Form” signed by the Contractor’s representative. Signature on form is for verification purposes only. Include the Design N-value calculation and resulting drilled pier length, “L,” on each form.

If non-standard site-specific poles are shown on the plans, submit completed boring logs collected in accordance with Section 2 (Soil Test) above along with pole loading diagrams from the plans to the contractor-selected pole fabricator to assist in the pole and foundation design.

If one of the following occurs, the Standard Foundations Chart shown on the plans may not be used and a non-standard foundation may be required. In such case, contact the Engineer.

- The Design N-value is less than 4.
- The drilled pier length, “L”, determined from the Standard Foundations Chart, is greater than the depth of the corresponding boring.

In the case where a standard foundation cannot be used, the Department will be responsible for the additional cost of the non-standard foundation.

Foundation designs are based on level ground around the traffic signal pole. If the slope around the edge of the drilled pier is steeper than 8:1 (H:V) or the proposed foundation will be less than 10 feet from the top of an embankment slope, the Contractor is responsible for providing slope information to the foundation designer and to the Engineer so it can be considered in the design.

The “Metal Pole Standard Foundation Selection Form” may be found at:

<http://www.ncdot.gov/doh/preconstruct/highway/geotech/formdet/misc/MetalPole.pdf>

If assistance is needed, contact the Engineer.

4. Non-Standard Foundation Design:

Design non-standard foundations based upon site-specific soil test information collected in accordance with Section 2 (Soil Test) above. Design drilled piers for side resistance only in accordance with Section 4.6 of the *AASHTO Standard Specifications for Highway Bridges*. Use the computer software LPILE version-6.0 or later manufactured by Ensoft, Inc. to analyze drilled piers. Use the computer software gINT V8i or later manufactured by Bentley Systems, Inc. with the current NCDOT gINT library and data template to produce SPT boring logs. Provide a drilled pier foundation for each pole with a length and diameter that result in a horizontal lateral movement of less than 1 inch at the top of the pier and a horizontal rotational movement of less than 1 inch at the edge of the pier. Contact the Engineer for pole loading diagrams for standard poles to be used for non-standard foundation designs. Submit any non-standard foundation designs including drawings, calculations, and soil boring logs to the Engineer for review and approval before construction.

C. Drilled Pier Construction:

Construct drilled pier foundations in accordance with the *Foundations and Anchor Rod Assemblies for Metal Poles* provision.

5.5. CUSTOM DESIGN OF TRAFFIC SIGNAL SUPPORTS

A. General:

Design traffic signal supports with foundations consisting of metal strain poles or metal poles with mast arms.

The lengths of the metal signal poles shown on the plans are estimated from available data for bid purposes. Determine the actual length of each pole from field measurements and adjusted cross-sections. Furnish the revised pole heights to the Engineer. Use all other dimensional requirements shown on the plans.

Ensure each pole includes an identification tag with information and location positions as defined on Metal Pole Standard Drawing Sheets M2, M3 and M4. All pole shaft tags must include the NCDOT Inventory number followed by the pole number shown on the traffic signal or ITS (non-signalized locations) plan.

Design all traffic signal support structures using the following 6th Edition AASHTO specifications:

- Design for a 50 year service life as recommended by Table 3.8.3-2.
- Use the wind pressure map developed from 3-second gust speeds, as provided in Article 3.8.
- Ensure signal support structures include natural wind gust loading and truck-induced gust loading in the fatigue design, as provided for in Articles 11.7.1.2 and 11.7.1.3, respectively. Designs need not consider periodic galloping forces.
- Assume the natural wind gust speed in North Carolina is 11.2 mph. For natural wind fatigue stress calculations, utilize a drag coefficient (C_d) computed for 11.2 mph wind velocity and not the basic wind speed velocity.
- Design for Category II fatigue, as provided for in Article 11.6, unless otherwise specified.
- Calculate all stresses using applicable equations from Section 5. The Maximum allowable stress ratios for all signal support designs are 0.9.
- Conform to article 10.4.2 and 11.8 for all deflection requirements.

Ensure that the design permits cables to be installed inside poles and mast arms.

Unless otherwise specified by special loading criteria, the computed surface area for ice load on signal heads is:

- 3-section, 12-inch, Surface area: 26.0 ft² (17.0 ft² without back plate)
- 4-section, 12-inch, Surface area: 32.0 ft² (21.0 ft² without back plate)
- 5-section, 12-inch, Surface area: 42.0 ft² (29.0 ft² without back plate)

The ice loading for signal heads defined above includes the additional surface area that back plates will induce. Special loading criteria may be specified in instances where back plates will not be installed on signal heads. Refer to the Loading Schedule on each Metal Pole Loading Diagram for revised signal head surface areas. The pole designer should revise ice loads accordingly in this instance. Careful examination of the plans when this is specified is important as this may impact sizing of the metal support structure and foundation design which could affect proposed bid quotes. All maximum stress ratios of 0.9 still apply.

Assume the combined minimum weight of a messenger cable bundle (including messenger cable, signal cable and detector lead-in cables) is 1.3 lbs/ft. Assume the combined minimum diameter of this cable bundle is 1.3 inches.

Ensure that designs provide a removable pole cap with stainless steel attachment screws for each pole top and mast arm end.

B. Metal Poles:

Submit design drawings for approval including pre-approved QPL pole drawings. Show all the necessary details and calculations for the metal poles including the foundation and connections. Include NCDOT inventory number on design drawings. Include as part of the design calculations the

ASTM specification numbers for the materials to be used. Provide the types and sizes of welds on the design drawings. Include a Bill of Materials on design drawings. Ensure design drawings and calculations are signed, dated, and sealed by the responsible professional engineer licensed in the state of North Carolina. Immediately bring to the attention of the Engineer any structural deficiency that becomes apparent in any assembly or member of any assembly as a result of the design requirements imposed by these specifications, the plans, or the typical drawings. Said Professional Engineer is wholly responsible for the design of all poles and arms. Review and acceptance of these designs by the Department does not relieve the said Professional Engineer of his responsibility. **Do not fabricate the assemblies until receipt of the Department's approval of the design drawings.**

For mast arm poles, provide designs with provisions for pole plates and associated gussets and fittings for mast arm attachment. As part of each mast arm attachment, provide a grommeted 2" diameter hole on the shaft side of the connection to allow passage of the signal cables from the pole to the arm.

Where ice is present, assume wind loads as shown in Figure 3.9.4.2-3 of the 6th Edition AASHTO Specification for Group III loading.

For each strain pole, provide two messenger cable clamps and associated hardware to attach the messenger support cable. Ensure that the diameter of the clamps is appropriately designed to be adjustable from 1'-6" inches below the top, down to 6'-6" below the top of the pole. Do not attach more than one messenger support cable to a messenger cable clamp.

Provide a grounding lug(s) in the approximate vicinity of the messenger cable clamp for bonding and grounding messenger cable. Lugs must accept #4 or #6 AWG wire to bond messenger cables to the pole in order to provide an effective ground fault circuit path. Refer to Metal Pole Standard Drawing Sheet M6 for construction details.

Design tapers for all pole shafts that begin at the base with diameters that decrease uniformly at the rate of 0.14 inch per foot of length.

Design a base plate on each pole. The minimum base plate thickness for all poles is determined by the following criteria:

Case 1 Circular or rectangular solid base plate with the upright pole welded to the top surface of base plate with full penetration butt weld, and where no stiffeners are provided. A base plate with a small center hole, which is less than 1/3 of the upright diameter, and located concentrically with the upright pole, may be considered as a solid base plate.

The magnitude of bending moment in the base plate, induced by the anchoring force of each anchor bolt is $M = (P \times D_1) / 2$, where

M = bending moment at the critical section of the base plate induced by one anchor bolt

P = anchoring force of each anchor bolt

D_1 = horizontal distance between the anchor bolt center and the outer face of the upright, or the difference between the bolt circle radius and the outside radius of the upright

Locate the critical section at the face of the anchor bolt and perpendicular to the bolt circle radius. The overlapped part of two adjacent critical sections is considered ineffective.

Case 2 Circular or rectangular base plate with the upright pole socketed into and attached to the base plate with two lines of fillet weld, and where no stiffeners are provided, or any base plate with a center hole that is larger in diameter than 1/3 of the upright diameter.

The magnitude of bending moment induced by the anchoring force of each anchor bolt is $M = P \times D_2$,

where P = anchoring force of each anchor bolt

D_2 = horizontal distance between the face of the upright and the face of the anchor bolt nut

Locate the critical section at the face of the anchor bolt top nut and perpendicular to the radius of the bolt circle. The overlapped part of two adjacent critical sections is considered ineffective.

If the base plate thickness calculated for Case 2 is less than Case 1, use the thickness calculated for Case 1.

The following additional owner requirements apply concerning pole base plates.

- Ensure that whichever case governs as defined above, the anchor bolt diameter is set to match the base plate thickness. If the minimum diameter required for the anchor bolt exceeds the thickness required for the base plate, set the base plate thickness equal to the required bolt diameter.
- For dual mast arm supports, or for single mast arm supports 50' or greater, use a minimum 8 bolt orientation with 2" diameter anchor bolts, and a 2" thick base plate.
- For all metal poles with mast arms, use a full penetration groove weld with a backing ring to connect the pole upright component to the base. Refer to Metal Pole Standard Drawing Sheet M4.

Ensure that designs have anchor bolt holes with a diameter 1/4 inch larger than the anchor bolt diameters in the base plate.

Ensure that the anchor bolts have the required diameters, lengths, and positions, and will develop strengths comparable to their respective poles.

Provide designs with a 6 x 12-inch hand hole with a reinforcing frame for each pole.

Provide designs with a terminal compartment with cover and screws in each pole that encompasses the hand hole and contains provisions for a 12-terminal barrier type terminal block.

For each pole, provide designs with provisions for a 1/2 inch minimum thread diameter, coarse thread stud and nut for grounding which will accommodate a #6 AWG ground wire. Ensure the lug is electrically bonded to the pole and is conveniently located inside the pole at the hand hole.

When required, design couplings on the pole for mounting pedestrian pushbuttons at a height of 42 inches above the bottom of the base. Provide mounting points consisting of 1-1/2 inch internally threaded half-couplings that comply with the NEC that are mounted within the poles. Ensure the couplings are essentially flush with the outside surfaces of the poles and are installed before any required galvanizing. Provide a threaded plug for each half coupling. Ensure that the surface of the plug is essentially flush with the outer end of the mounting point when installed and has a recessed hole to accommodate a standard wrench.

C. Mast Arms:

Design all arm plates and necessary attachment hardware, including bolts and brackets as required by the plans.

Design for grommets holes on the arms to accommodate the cables for the signals if specified.

Design arms with weatherproof connections for attaching to the shaft of the pole.

Always use a full penetration groove weld with a backing ring to connect the mast arm to the pole. Refer to Metal Pole Standard Drawing Sheet M5.

Capacity of tapped flange plate must be sufficient to develop the full capacity of the connecting bolts. In all cases the flange plate of both arm and shaft must be at least as thick as the arm connecting bolts are in diameter.

5.6. POLE NUMBERING SYSTEM

Attach an identification tag to each pole shaft and mast arm section as shown on Metal Pole Standard Drawing Sheet M2 “Typical Fabrication Details Common To All Metal Poles”.

5.7. MEASUREMENT AND PAYMENT

Actual number of metal strain signal poles (without regard to height or load capacity) furnished, installed and accepted.

Actual number of metal poles with single mast arms furnished, installed, and accepted.

Actual number of metal poles with dual mast arms furnished, installed, and accepted.

Actual number of soil tests with SPT borings drilled furnished and accepted.

Actual volume of concrete poured in cubic yards of drilled pier foundation furnished, installed and accepted.

Actual number of designs for mast arms with metal poles furnished and accepted.

No measurement will be made for foundation designs prepared with metal pole designs, as these will be considered incidental to designing signal support structures.

Payment will be made under:

| | |
|---------------------------------------|------------|
| Metal Strain Signal Pole | Each |
| Metal Pole with Single Mast Arm | Each |
| Metal Pole with Dual Mast Arm..... | Each |
| Soil Test | Each |
| Drilled Pier Foundation..... | Cubic Yard |
| Mast Arm with Metal Pole Design | Each |

6. CONTROLLERS WITH CABINETS

6.1. MATERIALS – TYPE 2070L CONTROLLERS

Conform to CALTRANS *Transportation Electrical Equipment Specifications (TEES)* (dated August 16, 2002, plus Errata 1 dated October 27, 2003 and Errata 2 dated June 08, 2004) except as required herein.

Furnish Model 2070L controllers. Ensure that removal of the CPU module from the controller will place the intersection into flash.

The Department will provide software at the beginning of the burning-in period. Contractor shall give 5 working days notice before needing software. Program software provided by the Department.

Provide model 2070L controllers with the latest version of OS9 operating software and device drivers, composed of the unit chassis and at a minimum the following modules and assemblies:

- MODEL 2070 1B, CPU Module, Single Board
- MODEL 2070-2A, Field I/O Module (FI/O)
 - Note: Configure the Field I/O Module to disable both the External WDT Shunt/Toggle Switch and SP3 (SP3 active indicator is “off”)
- MODEL 2070-3B, Front Panel Module (FP), Display B (8x40)
- MODEL 2070-4A, Power Supply Module, 10 AMP
- MODEL 2070-7A, Async Serial Com Module (9-pin RS-232)

Furnish one additional MODEL 2070-7A, Async Serial Com Module (9-pin RS-232) for all master controller locations.

For each master location and central control center, furnish a U.S. Robotics V.92 or approved equivalent auto-dial/auto-answer external modem to accomplish the interface to the Department-furnished microcomputers. Include all necessary hardware to ensure telecommunications.

6.2. MATERIALS – GENERAL CABINETS

Provide a moisture resistant coating on all circuit boards.

Provide one 20 mm diameter radial lead UL-recognized metal oxide varistor (MOV) between each load switch field terminal and equipment ground. Electrical performance is outlined below.

| PROPERTIES OF MOV SURGE PROTECTOR | |
|--|--------------------------|
| Maximum Continuous Applied Voltage at 185° F | 150 VAC (RMS) 200 VDC |
| Maximum Peak 8x20µs Current at 185° F | 6500 A |
| Maximum Energy Rating at 185° F | 80 J |
| Voltage Range 1 mA DC Test at 77° F | 212-268 V |
| Max. Clamping Voltage 8x20µs, 100A at 77° F | 395 V |
| Typical Capacitance (1 MHz) at 77° F | 1600 pF |

Provide a power line surge protector that is a two-stage device that will allow connection of the radio frequency interference filter between the stages of the device. Ensure that a maximum continuous current is at least 10A at 120V. Ensure that the device can withstand a minimum of 20 peak surge current occurrences at 20,000A for an 8x20 microsecond waveform. Provide a maximum

clamp voltage of 395V at 20,000A with a nominal series inductance of 200 μ h. Ensure that the voltage does not exceed 395V. Provide devices that comply with the following:

| Frequency (Hz) | Minimum Insertion Loss (dB) |
|----------------|-----------------------------|
| 60 | 0 |
| 10,000 | 30 |
| 50,000 | 55 |
| 100,000 | 50 |
| 500,000 | 50 |
| 2,000,000 | 60 |
| 5,000,000 | 40 |
| 10,000,000 | 20 |
| 20,000,000 | 25 |

6.3. MATERIALS – TYPE 170E CABINETS

A. Type 170 E Cabinets General:

Conform to the city of Los Angeles' Specification No. 54-053-08, *Traffic Signal Cabinet Assembly Specification* (dated July 2008), except as required herein.

Furnish model 336S pole mounted cabinets configured for 8 vehicle phases, 4 pedestrian phases, and 6 overlaps. Do not reassign load switches to accommodate overlaps unless shown on electrical details. Provide 336S pole mounted cabinets that are 46" high with 40" high internal rack assemblies.

Furnish model 332 base mounted cabinets configured for 8 vehicle phases, 4 pedestrian phases, and 6 overlaps. When overlaps are required, provide auxiliary output files for the overlaps. Do not reassign load switches to accommodate overlaps unless shown on electrical details.

Provide model 200 load switches, model 222 loop detector sensors, model 252 AC isolators, and model 242 DC isolators according to the electrical details. As a minimum, provide one (1) model 2018 conflict monitor, one (1) model 206L power supply unit, two (2) model 204 flashers, one (1) DC isolator (located in slot I14), and four (4) model 430 flash transfer relays (provide seven (7) model 430 flash transfer relays if auxiliary output file is installed) with each cabinet.

B. Type 170 E Cabinet Electrical Requirements:

Provide a cabinet assembly designed to ensure that upon leaving any cabinet switch or conflict monitor initiated flashing operation, the controller starts up in the programmed start up phases and start up interval.

Furnish two sets of non-fading cabinet wiring diagrams and schematics in a paper envelope or container and placed in the cabinet drawer.

All AC+ power is subject to radio frequency signal suppression.

Provide surge suppression in the cabinet for each type of cabinet device. Provide surge protection for the full capacity of the cabinet input file. Provide surge suppression devices that operate properly over a temperature range of -40° F to +185° F. Ensure the surge suppression devices provide both common and differential modes of protection.

Provide a pluggable power line surge protector that is installed on the back of the PDA (power distribution assembly) chassis to filter and absorb power line noise and switching transients. Ensure the device incorporates LEDs for failure indication and provides a dry relay contact closure for the purpose of remote sensing. Ensure the device meets the following specifications:

- Peak Surge Current (Single pulse, 8x20µs).....20,000A
- Occurrences (8x20µs waveform).....10 minimum @ 20,000A
- Maximum Clamp Voltage.....395VAC
- Operating Current.....15 amps
- Response Time.....< 5 nanoseconds

Provide a loop surge suppressor for each set of loop terminals in the cabinet. Ensure the device meets the following specifications:

- Peak Surge Current (6 times, 8x20µs)
 - (Differential Mode).....400A
 - (Common Mode).....1,000A
- Occurrences (8x20µs waveform).....500 min @ 200A
- Maximum Clamp Voltage
 - (Differential Mode @400A).....35V
 - (Common Mode @1,000A).....35V
- Response Time.....< 5 nanoseconds
- Maximum Capacitance.....35 pF

Provide a data communications surge suppressor for each communications line entering or leaving the cabinet. Ensure the device meets the following specifications:

- Peak Surge Current (Single pulse, 8x20µs).....10,000A
- Occurrences (8x20µs waveform).....100 min @ 2,000A
- Maximum Clamp Voltage.....Rated for equipment protected
- Response Time.....< 1 nanosecond
- Maximum Capacitance.....1,500 pF
- Maximum Series Resistance.....15Ω

Provide a DC signal surge suppressor for each DC input channel in the cabinet. Ensure the device meets the following specifications:

- Peak Surge Current (Single pulse, 8x20µs).....10,000A

- Occurrences (8x20µs waveform).....100 @ 2,000A
- Maximum Clamp Voltage.....30V
- Response Time.....< 1 nanosecond

Provide a 120 VAC signal surge suppressor for each AC+ interconnect signal input. Ensure the device meets the following specifications:

- Peak Surge Current (Single pulse, 8x20µs).....20,000A
- Maximum Clamp Voltage.....350VAC
- Response Time.....< 200 nanoseconds
- Discharge Voltage.....<200 Volts @ 1,000A
- Insulation Resistance.....≥100 MΩ

Provide conductors for surge protection wiring that are of sufficient size (ampacity) to withstand maximum overcurrents which could occur before protective device thresholds are attained and current flow is interrupted.

If additional surge protected power outlets are needed to accommodate fiber transceivers, modems, etc., install a UL listed, industrial, heavy-duty type power outlet strip with a minimum rating of 15 A / 125 VAC, 60 Hz. Provide a strip that has a minimum of 3 grounded outlets. Ensure the power outlet strip plugs into one of the controller unit receptacles located on the rear of the PDA. Ensure power outlet strip is mounted securely; provide strain relief if necessary.

Provide a door switch in the front and a door switch in the rear of the cabinet that will provide the controller unit with a Door Ajar alarm when either the front or the rear door is open. Ensure the door switches apply DC ground to the Input File when either the front door or the rear door is open.

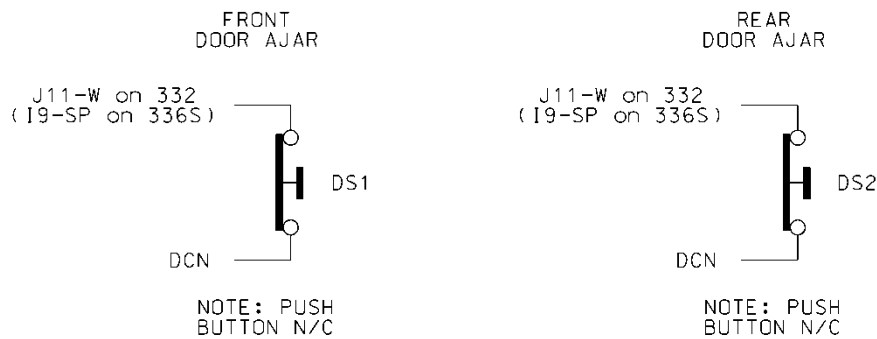

Furnish a fluorescent fixture in the rear across the top of the cabinet and another fluorescent fixture in the front across the top of the cabinet at a minimum. Ensure that the fixtures provide sufficient light to illuminate all terminals, labels, switches, and devices in the cabinet. Conveniently locate the fixtures so as not to interfere with a technician’s ability to perform work on any devices or terminals in the cabinet. Provide a protective diffuser to cover exposed bulbs. Install 16 watt T-4 lamps in the fluorescent fixtures. Provide a door switch to provide power to each fixture when the respective door is open. Wire the fluorescent fixtures to the 15 amp ECB (equipment circuit breaker).

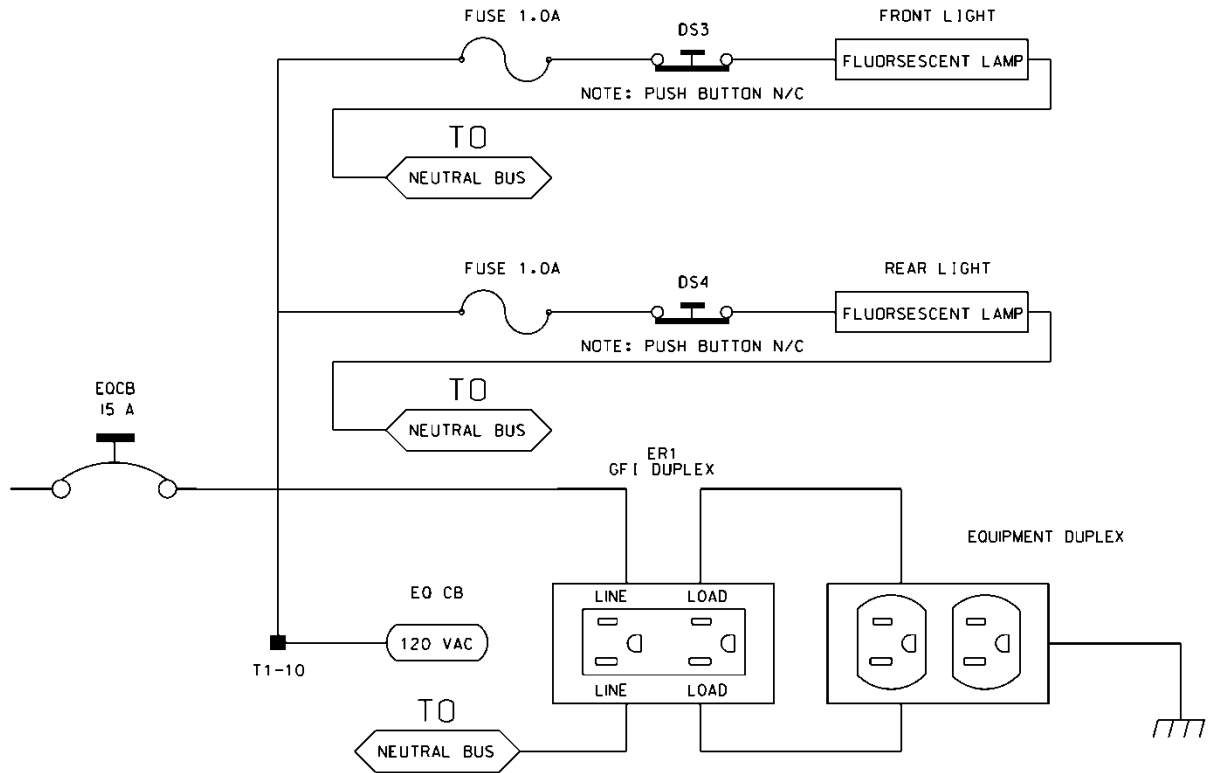

Furnish a police panel with a police panel door. For model 336S cabinets, mount the police panel on the rear door. Ensure that the police panel door permits access to the police panel when the main door is closed. Ensure that no rainwater can enter the cabinet even with the police panel door open. Provide a police panel door hinged on the right side as viewed from the front. Provide a police panel door lock that is keyed to a standard police/fire call box key. In addition to the requirements of LA Specification No. 54-053-08, provide the police panel with a toggle switch connected to switch the intersection operation between normal stop-and-go operation (AUTO) and manual operation (MANUAL). Ensure that manual control can be implemented using inputs and software such that the controller provides full programmed clearance times for the yellow clearance and red clearance for each phase while under manual control.

Provide a 1/4-inch locking phone jack in the police panel for a hand control to manually control the intersection. Provide sufficient room in the police panel for storage of a hand control and cord.

Ensure the 336S cabinet Input File is wired as follows:

| 336S Cabinet | | | | | | | | | | | | | | |
|-----------------------------|-----|-----|-----|-----|-----|-----|-----|-----|-----|-----|-----|-----|-----|-----|
| Port-Bit/C-1 Pin Assignment | | | | | | | | | | | | | | |
| Slot # | 1 | 2 | 3 | 4 | 5 | 6 | 7 | 8 | 9 | 10 | 11 | 12 | 13 | 14 |
| C-1 (Spares) | 59 | 60 | 61 | 62 | 63 | 64 | 65 | 66 | 75 | 76 | 77 | 78 | 79 | 80 |
| Port C-1 | 3-2 | 1-1 | 3-4 | 1-3 | 3-1 | 1-2 | 3-3 | 1-4 | 2-5 | 5-5 | 5-6 | 5-1 | 5-2 | 6-7 |
| Port C-1 | 56 | 39 | 58 | 41 | 55 | 40 | 57 | 42 | 51 | 71 | 72 | 67 | 68 | 81 |
| Port C-1 | 2-1 | 1-5 | 2-3 | 1-7 | 2-2 | 1-6 | 2-4 | 1-8 | 2-6 | 5-7 | 5-8 | 5-3 | 5-4 | 6-8 |
| Port C-1 | 47 | 43 | 49 | 45 | 48 | 44 | 50 | 46 | 52 | 73 | 74 | 69 | 70 | 82 |

For model 332 base mounted cabinets, ensure terminals J14-E and J14-K are wired together on the rear of the Input File. Connect TB9-12 (J14 Common) on the Input Panel to T1-2 (AC-) on the rear of the PDA.

Provide detector test switches mounted at the top of the cabinet rack or other convenient location which may be used to place a call on each of eight phases based on the chart below. Provide three positions for each switch: On (place call), Off (normal detector operation), and Momentary On (place momentary call and return to normal detector operation after switch is released). Ensure that the switches are located such that the technician can read the controller display and observe the intersection.

Connect detector test switches for cabinets as follows:

| 336S Cabinet | | 332 Cabinet | |
|------------------------|-----------|------------------------|-----------|
| Detector Call Switches | Terminals | Detector Call Switches | Terminals |
| Phase 1 | I1-F | Phase 1 | I1-W |
| Phase 2 | I2-F | Phase 2 | I4-W |
| Phase 3 | I3-F | Phase 3 | I5-W |
| Phase 4 | I4-F | Phase 4 | I8-W |
| Phase 5 | I5-F | Phase 5 | J1-W |
| Phase 6 | I6-F | Phase 6 | J4-W |
| Phase 7 | I7-F | Phase 7 | J5-W |
| Phase 8 | I8-F | Phase 8 | J8-W |

Provide the PCB 28/56 connector for the conflict monitor unit (CMU) with 28 independent contacts per side, dual-sided with 0.156 inch contact centers. Provide the PCB 28/56 connector contacts with solder eyelet terminations. Ensure all connections to the PCB 28/56 connector are soldered to the solder eyelet terminations.

Ensure that all cabinets have the CMU connector wired according to the 332 cabinet connector pin assignments (include all wires for auxiliary output file connection). Wire pins 13, 16, R, and U

of the CMU connector to a separate 4 pin plug, P1, as shown below. Provide a second plug, P2, which will mate with P1 and is wired to the auxiliary output file as shown below. Provide an additional plug, P3, which will mate with P1 and is wired to the pedestrian yellow circuits as shown below. When no auxiliary output file is installed in the cabinet, provide wires for the green and yellow inputs for channels 11, 12, 17, and 18, the red inputs for channels 17 and 18, and the wires for the P2 plug. Terminate the two-foot wires with ring type lugs, insulated, and bundled for optional use.

| PIN | P1 | | P2 | | P3 | |
|-----|----------|---------|----------|---------|----------|---------|
| | FUNCTION | CONN TO | FUNCTION | CONN TO | FUNCTION | CONN TO |
| 1 | CH-9G | CMU-13 | OLA-GRN | A123 | 2P-YEL | 114 |
| 2 | CH-9Y | CMU-16 | OLA-YEL | A122 | 4P-YEL | 105 |
| 3 | CH-10G | CMU-R | OLB-GRN | A126 | 6P-YEL | 120 |
| 4 | CH-10Y | CMU-U | OLB-YEL | A125 | 8P-YEL | 111 |

Do not provide the P20 terminal assembly (red monitor board) or red interface ribbon cable as specified in LA Specification No. 54-053-08.

Provide a P20 connector that mates with and is compatible with the red interface connector mounted on the front of the conflict monitor. Ensure that the P20 connector and the red interface connector on the conflict monitor are center polarized to ensure proper connection. Ensure that removal of the P20 connector will cause the conflict monitor to recognize a latching fault condition and place the cabinet into flashing operation.

Wire the P20 connector to the output file and auxiliary output file using 22 AWG stranded wires. Ensure the length of these wires is a minimum of 42 inches in length. Provide a durable braided sleeve around the wires to organize and protect the wires.

Wire the P20 connector to the traffic signal red displays to provide inputs to the conflict monitor as shown below. Ensure the pedestrian Don't Walk circuits are wired to channels 13 through 16 of the P20 connector. When no auxiliary output file is installed in the cabinet, provide wires for channels 9 through 12 reds. Provide a wire for special function 1. Terminate the unused wires with ring type lugs, insulated, and bundled for optional use.

| P20 Connector | | | | | |
|---------------|----------------|---------|-----|-----------------|---------|
| PIN | FUNCTION | CONN TO | PIN | FUNCTION | CONN TO |
| 1 | Channel 15 Red | 119 | 2 | Channel 16 Red | 110 |
| 3 | Channel 14 Red | 104 | 4 | Chassis GND | 01-9 |
| 5 | Channel 13 Red | 113 | 6 | N/C | |
| 7 | Channel 12 Red | AUX 101 | 8 | Spec Function 1 | |
| 9 | Channel 10 Red | AUX 124 | 10 | Channel 11 Red | AUX 114 |
| 11 | Channel 9 Red | AUX 121 | 12 | Channel 8 Red | 107 |
| 13 | Channel 7 Red | 122 | 14 | Channel 6 Red | 134 |
| 15 | Channel 5 Red | 131 | 16 | Channel 4 Red | 101 |
| 17 | Channel 3 Red | 116 | 18 | Channel 2 Red | 128 |
| 19 | Channel 1 Red | 125 | 20 | Red Enable | 01-14 |

Ensure the controller unit outputs to the auxiliary output file are pre-wired to the C5 connector. When no auxiliary output file is installed in the cabinet, connect the C5 connector to a storage socket located on the Input Panel or on the rear of the PDA.

Do not wire pin 12 of the load switch sockets.

In addition to the requirements of LA Specification No. 54-053-08, ensure relay K1 on the Power Distribution Assembly (PDA) is a four pole relay and K2 on the PDA is a two pole relay.

Provide a two pole, ganged circuit breaker for the flash bus circuit. Ensure the flash bus circuit breaker is an inverse time circuit breaker rated for 10 amps at 120 VAC with a minimum of 10,000 RMS symmetrical amperes short circuit current rating. Do not provide the auxiliary switch feature on the flash bus circuit breaker. Ensure the ganged flash bus circuit breaker is certified by the circuit breaker manufacturer to provide gang tripping operation.

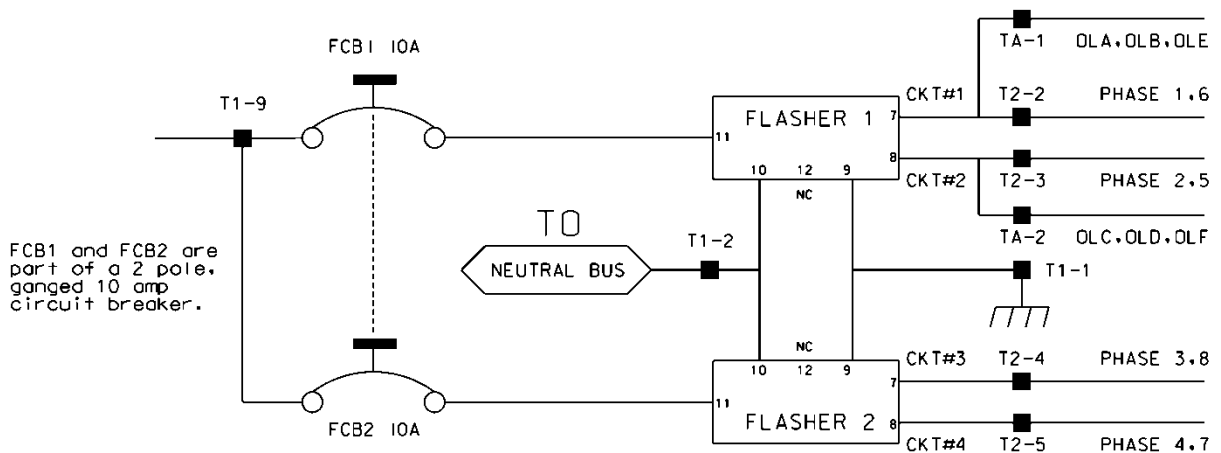

Ensure auxiliary output files are wired as follows:

| AUXILIARY OUTPUT FILE | |
|--------------------------------------|---|
| TERMINAL BLOCK TA ASSIGNMENTS | |
| POSITION | FUNCTION |
| 1 | Flasher Unit #1, Circuit 1/FTR1 (OLA, OLB)/FTR3 (OLE) |
| 2 | Flasher Unit #1, Circuit 2/FTR2 (OLC, OLD)/FTR3 (OLF) |
| 3 | Flash Transfer Relay Coils |
| 4 | AC - |
| 5 | Power Circuit 5 |
| 6 | Power Circuit 5 |
| 7 | Equipment Ground Bus |
| 8 | NC |

Provide four spare load resistors mounted in each cabinet. Ensure each load resistor is rated as shown in the table below. Wire one side of each load resistor to AC-. Connect the other side of each resistor to a separate terminal on a four (4) position terminal block. Mount the load resistors and terminal block either inside the back of Output File No. 1 or on the upper area of the Service Panel.

| ACCEPTABLE LOAD RESISTOR VALUES | |
|---------------------------------|-----------|
| VALUE (ohms) | WATTAGE |
| 1.5K – 1.9 K | 25W (min) |
| 2.0K – 3.0K | 10W (min) |

Provide Model 200 load switches, Model 204 flashers, Model 242 DC isolators, Model 252 AC isolators, and Model 206L power supply units that conform to CALTRANS' *“Transportation Electrical Equipment Specifications”* dated March 12, 2009 with Erratum 1.

C. Type 170 E Cabinet Physical Requirements:

Do not mold, cast, or scribe the name “City of Los Angeles” on the outside of the cabinet door as specified in LA Specification No. 54-053-08. Do not provide a Communications Terminal Panel as specified in LA Specification No. 54-053-08. Do not provide terminal block TBB on the Service Panel. Do not provide Cabinet Verification Test Program software or associated test jigs as specified in LA Specification No. 54-053-08.

Furnish unpainted, natural, aluminum cabinet shells. Ensure that all non-aluminum hardware on the cabinet is stainless steel or a Department approved non-corrosive alternate.

Ensure the lifting eyes, gasket channels, police panel, and all supports welded to the enclosure and doors are fabricated from 0.125 inch minimum thickness aluminum sheet and meet the same standards as the cabinet and doors.

Provide front and rear doors with latching handles that allow padlocking in the closed position. Furnish 0.75 inch minimum diameter stainless steel handles with a minimum 0.5 inch shank. Place the padlocking attachment at 4.0 inches from the handle shank center to clear the lock and key. Provide an additional 4.0 inches minimum gripping length.

Provide Corbin #2 locks on the front and rear doors. Provide one (1) Corbin #2 and one (1) police master key with each cabinet. Ensure main door locks allow removal of keys in the locked position only.

Provide a surge protection panel with 16 loop surge protection devices and designed to allow sufficient free space for wire connection/disconnection and surge protection device replacement. For model 332 cabinets, provide an additional 20 loop surge protection devices. Provide an additional two AC+ interconnect surge devices to protect one slot and eight DC surge protection devices to protect four slots. Provide no protection devices on slot I14.

For pole mounted cabinets, mount surge protection devices for the AC+ interconnect inputs, inductive loop detector inputs, and low voltage DC inputs on a swing down panel assembly fabricated from sturdy aluminum. Attach the swing down panel to the bottom rear cabinet rack

assembly using thumb screws. Ensure the swing down panel allows for easy removal of the input file without removing the surge protection panel assembly or its parts. Have the surge protection devices mounted horizontally on the panel and soldered to the feed through terminals of four 14 position terminal blocks with #8 screws mounted on the other side. Ensure the top row of terminals is connected to the upper slots and the bottom row of terminals is connected to the bottom slots. Provide a 15 position copper equipment ground bus attached to the field terminal side (outside) of the swing down panel for termination of loop lead-in shield grounds. Ensure that a Number 4 AWG green wire connects the surge protection panel assembly ground bus to the main cabinet equipment ground.

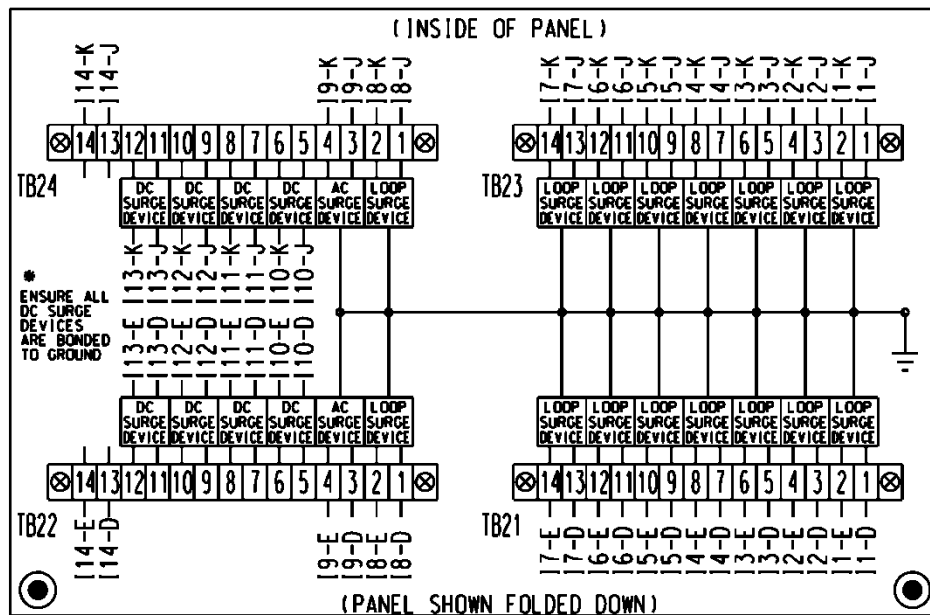
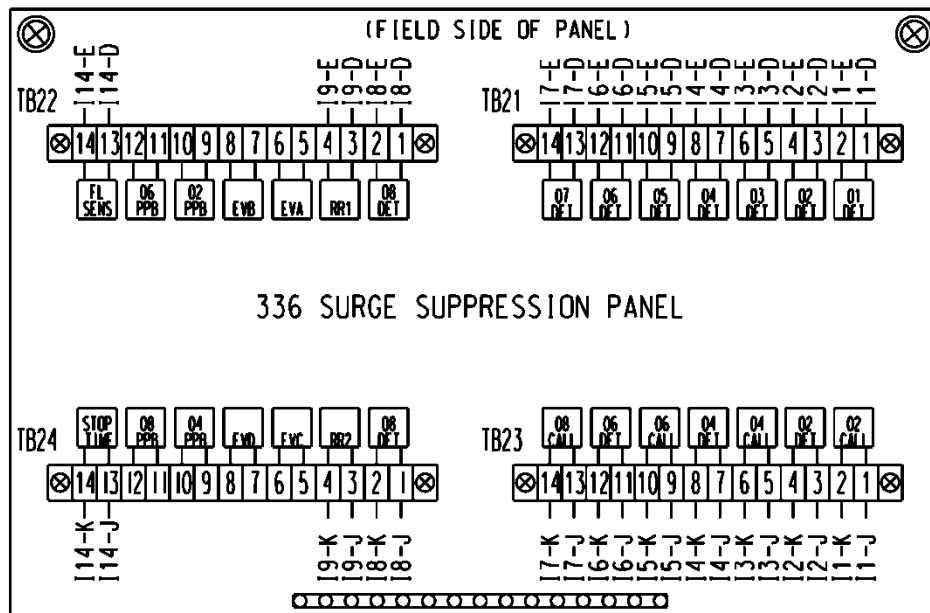

For base mounted cabinets, mount surge protection panels on the left side of the cabinet as viewed from the rear. Attach each panel to the cabinet rack assembly using bolts and make it easily removable. Mount the surge protection devices in vertical rows on each panel and connect the devices to one side of 12 position, double row terminal blocks with #8 screws. For each surge protection panel, terminate all grounds from the surge protection devices on a copper equipment ground bus attached to the surge protection panel. Wire the terminals to the rear of a standard input file using spade lugs for input file protection.

Provide permanent labels that indicate the slot and the pins connected to each terminal that may be viewed from the rear cabinet door. Label and orient terminals so that each pair of inputs is next to each other. Indicate on the labeling the input file (I or J), the slot number (1-14) and the terminal pins of the input slots (either D & E for upper or J & K for lower).

Provide a minimum 14 x 16 inch pull out, hinged top shelf located immediately below controller mounting section of the cabinet. Ensure the shelf is designed to fully expose the table surface outside the controller at a height approximately even with the bottom of the controller. Ensure the shelf has a storage bin interior which is a minimum of 1 inch deep and approximately the same dimensions as the shelf. Provide an access to the storage area by lifting the hinged top of the shelf. Fabricate the shelf and slide from aluminum or stainless steel and ensure the assembly can support the 2070L controller plus 15 pounds of additional weight. Ensure shelf has a locking mechanism to secure it in the fully extended position and does not inhibit the removal of the 2070L controller or removal of cards inside the controller when fully extended. Provide a locking mechanism that is easily released when the shelf is to be returned to its non-use position directly under the controller.

D. Model 2018 Enhanced Conflict Monitor:

Furnish Model 2018 Enhanced Conflict Monitors that provide monitoring of 18 channels. Ensure each channel consists of a green, yellow, and red field signal input. Ensure that the conflict monitor meets or exceeds CALTRANS' Transportation Electrical Equipment Specifications dated March 12, 2009, with Erratum 1 (hereafter referred to as CALTRANS' 2009 TEES) for a model 210 monitor unit and other requirements stated in this specification.

Ensure the conflict monitor is provided with an 18 channel conflict programming card. Pin EE and Pin T of the conflict programming card shall be connected together. Pin 16 of the conflict programming card shall be floating. Ensure that the absence of the conflict programming card will cause the conflict monitor to trigger (enter into fault mode), and remain in the triggered state until the programming card is properly inserted and the conflict monitor is reset.

Provide a conflict monitor that incorporates LED indicators into the front panel to dynamically display the status of the monitor under normal conditions and to provide a comprehensive review of field inputs with monitor status under fault conditions. Ensure that the monitor indicates the channels that were active during a conflict condition and the channels that experienced a failure for all other per channel fault conditions detected. Ensure that these indications and the status of each channel are retained until the Conflict Monitor is reset. Furnish LED indicators for the following:

- AC Power (Green LED indicator)
- VDC Failed (Red LED indicator)
- WDT Error (Red LED indicator)
- Conflict (Red LED indicator)
- Red Fail (Red LED indicator)

- Dual Indication (Red LED indicator)
- Yellow/Clearance Failure (Red LED indicator)
- PCA/PC Ajar (Red LED indicator)
- Monitor Fail/Diagnostic Failure (Red LED indicator)
- 54 Channel Status Indicators (1 Red, 1 Yellow, and 1 Green LED indicator for each of the 18 channels)

Provide a switch to set the Red Fail fault timing. Ensure that when the switch is in the ON position the Red Fail fault timing value is set to 1350 +/- 150 ms (2018 mode). Ensure that when the switch is in the OFF position the Red Fail fault timing value is set to 850 +/- 150 ms (210 mode).

Provide a switch to set the Watchdog fault timing. Ensure that when the switch is in the ON position the Watchdog fault timing value is set to 1.0 +/- 0.1 s (2018 mode). Ensure that when the switch is in the OFF position the Watchdog fault timing value is set to 1.5 +/- 0.1 s (210 mode).

Provide a jumper or switch to set the AC line brown-out levels. Ensure that when the jumper is present or the switch is in the ON position the AC line dropout voltage threshold is 98 +/- 2 Vrms, the AC line restore voltage threshold is 103 +/- 2 Vrms, and the AC line brown-out timing value is set to 400 +/- 50ms (2018 mode). Ensure that when the jumper is not present or the switch is in the OFF position the AC line dropout voltage threshold is 92 +/- 2 Vrms, the AC line restore voltage threshold is 98 +/- 2 Vrms, and the AC line brown-out timing value is set to 80 +/- 17 ms (210 mode).

Provide a jumper or switch that will enable and disable the Watchdog Latch function. Ensure that when the jumper is not present or the switch is in the OFF position the Watchdog Latch function is disabled. In this mode of operation, a Watchdog fault will be reset following a power loss, brownout, or power interruption. Ensure that when the jumper is present or the switch is in the ON position the Watchdog Latch function is enabled. In this mode of operation, a Watchdog fault will be retained until a Reset command is issued.

Provide a jumper that will reverse the active polarity for pin #EE (output relay common). Ensure that when the jumper is not present pin #EE (output relay common) will be considered 'Active' at a voltage greater than 70 Vrms and 'Not Active' at a voltage less than 50 Vrms (Caltrans mode). Ensure that when the jumper is present pin #EE (output relay common) will be considered 'Active' at a voltage less than 50 Vrms and 'Not Active' at a voltage greater than 70 Vrms (Failsafe mode).

In addition to the connectors required by CALTRANS' 2009 TEES, provide the conflict monitor with a red interface connector mounted on the front of the monitor. Ensure the connector is a 20 pin, right angle, center polarized, male connector with latching clip locks and polarizing keys. Ensure the right angle solder tails are designed for a 0.062" thick printed circuit board. Keying of the connector shall be between pins 3 and 5, and between 17 and 19. Ensure the connector has two rows of pins with the odd numbered pins on one row and the even pins on the other row. Ensure the connector pin row spacing is 0.10" and pitch is 0.10". Ensure the mating length of the connector pins is 0.24". Ensure the pins are finished with gold plating 30μ" thick.

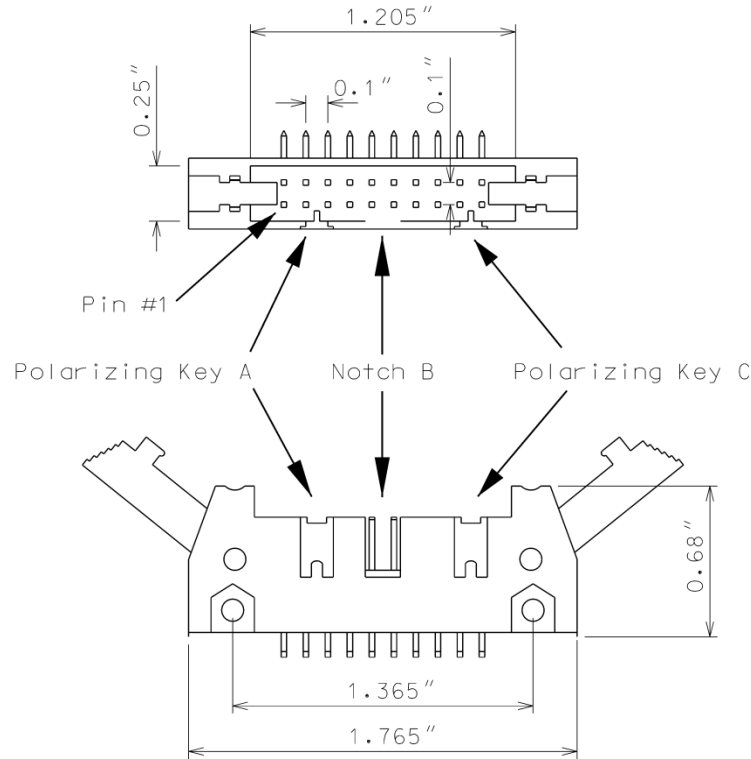

Ensure the red interface connector pins on the monitor have the following functions:

| Pin # | Function | Pin # | Function |
|-------|----------------|-------|--------------------|
| 1 | Channel 15 Red | 2 | Channel 16 Red |
| 3 | Channel 14 Red | 4 | Chassis Ground |
| 5 | Channel 13 Red | 6 | Special Function 2 |
| 7 | Channel 12 Red | 8 | Special Function 1 |
| 9 | Channel 10 Red | 10 | Channel 11 Red |
| 11 | Channel 9 Red | 12 | Channel 8 Red |
| 13 | Channel 7 Red | 14 | Channel 6 Red |
| 15 | Channel 5 Red | 16 | Channel 4 Red |
| 17 | Channel 3 Red | 18 | Channel 2 Red |
| 19 | Channel 1 Red | 20 | Red Enable |

Ensure that removal of the P20 cable connector will cause the conflict monitor to recognize a latching fault condition and place the cabinet into flashing operation.

Provide Special Function 1 and Special Function 2 inputs to the unit which shall disable only Red Fail Monitoring when either input is sensed active. A Special Function input shall be sensed active when the input voltage exceeds 70 Vrms with a minimum duration of 550 ms. A Special Function

input shall be sensed not active when the input voltage is less than 50 Vrms or the duration is less than 250 ms. A Special Function input is undefined by these specifications and may or may not be sensed active when the input voltage is between 50 Vrms and 70 Vrms or the duration is between 250 ms and 550 ms.

Ensure the conflict monitor recognizes field signal inputs for each channel that meet the following requirements:

- consider a Red input greater than 70 Vrms and with a duration of at least 500 ms as an “on” condition;
- consider a Red input less than 50 Vrms or with a duration of less than 200 ms as an “off” condition (no valid signal);
- consider a Red input between 50 Vrms and 70 Vrms or with a duration between 200 ms and 500 ms to be undefined by these specifications;
- consider a Green or Yellow input greater than 25 Vrms and with a duration of at least 500 ms as an “on” condition;
- consider a Green or Yellow input less than 15 Vrms or with a duration of less than 200 ms as an “off” condition; and
- consider a Green or Yellow input between 15 Vrms and 25 Vrms or with a duration between 200 ms and 500 ms to be undefined by these specifications.

Provide a conflict monitor that recognizes the faults specified by CALTRANS’ 2009 TEES and the following additional faults. Ensure the conflict monitor will trigger upon detection of a fault and will remain in the triggered (in fault mode) state until the unit is reset at the front panel or through the external remote reset input for the following failures:

1. **Red Monitoring or Absence of Any Indication (Red Failure):** A condition in which no “on” voltage signal is detected on any of the green, yellow, or red inputs to a given monitor channel. If a signal is not detected on at least one input (R, Y, or G) of a conflict monitor channel for a period greater than 1000 ms when used with a 170 controller and 1500 ms when used with a 2070 controller, ensure monitor will trigger and put the intersection into flash. If the absence of any indication condition lasts less than 700 ms when used with a 170 controller and 1200 ms when used with a 2070 controller, ensure conflict monitor will not trigger. Red fail monitoring shall be enabled on a per channel basis by the use of switches located on the conflict monitor. Have red monitoring occur when all of the following input conditions are in effect:
 - a) Red Enable input to monitor is active (Red Enable voltages are “on” at greater than 70 Vrms, off at less than 50 Vrms, undefined between 50 and 70 Vrms), and
 - b) Neither Special Function 1 nor Special Function 2 inputs are active.
 - c) Pin #EE (output relay common) is not active
2. **Short/Missing Yellow Indication Fault (Clearance Error):** Yellow indication following a green is missing or shorter than 2.7 seconds (with ± 0.1 -second accuracy). If a channel fails to detect an “on” signal at the Yellow input for a minimum of 2.7 seconds (± 0.1 second) following the detection of an “on” signal at a Green input for that channel, ensure that the monitor triggers and generates a clearance/short yellow error fault indication. Short/missing yellow (clearance) monitoring shall be enabled on a per channel basis by the use of switches

located on the conflict monitor. This fault shall not occur when the channel is programmed for Yellow Inhibit, when the Red Enable signal is inactive or pin #EE (output relay common) is active.

3. **Dual Indications on the Same Channel:** In this condition, more than one indication (R,Y,G) is detected as “on” at the same time on the same channel. If dual indications are detected for a period greater than 500 ms, ensure that the conflict monitor triggers and displays the proper failure indication (Dual Ind fault). If this condition is detected for less than 200 ms, ensure that the monitor does not trigger. G-Y-R dual indication monitoring shall be enabled on a per channel basis by the use of switches located on the conflict monitor. G-Y dual indication monitoring shall be enabled for all channels by use of a switch located on the conflict monitor. This fault shall not occur when the Red Enable signal is inactive or pin #EE (output relay common) is active.
4. **Configuration Settings Change:** The configuration settings are comprised of (as a minimum) the permissive diode matrix, dual indication switches, yellow disable jumpers, any option switches, any option jumpers, and the Watchdog Enable switch. Ensure the conflict monitor compares the current configuration settings with the previous stored configuration settings on power-up, on reset, and periodically during operation. If any of the configuration settings are changed, ensure that the conflict monitor triggers and causes the program card indicator to flash. Ensure that configuration change faults are only reset by depressing and holding the front panel reset button for a minimum of three seconds. Ensure the external remote reset input does not reset configuration change faults.

Ensure the conflict monitor will trigger and the AC Power indicator will flash at a rate of $2 \text{ Hz} \pm 20\%$ with a 50% duty cycle when the AC Line voltage falls below the “drop-out” level. Ensure the conflict monitor will resume normal operation when the AC Line voltage returns above the “restore” level. Ensure the AC Power indicator will remain illuminated when the AC voltage returns above the “restore” level. Should an AC Line power interruption occur while the monitor is in the fault mode, then upon restoration of AC Line power, the monitor will remain in the fault mode and the correct fault and channel indicators will be displayed.

Provide a flash interval of at least 6 seconds and at most 10 seconds in duration following a power-up, an AC Line interruption, or a brownout restore. Ensure the conflict monitor will suspend all fault monitoring functions, close the Output relay contacts, and flash the AC indicator at a rate of $4 \text{ Hz} \pm 20\%$ with a 50% duty cycle during this interval. Ensure the termination of the flash interval after at least 6 seconds if the Watchdog input has made 5 transitions between the True and False state and the AC Line voltage is greater than the “restore” level. If the watchdog input has not made 5 transitions between the True and False state within 10 ± 0.5 seconds, the monitor shall enter a WDT error fault condition.

Ensure the conflict monitor will monitor an intersection with a minimum of four approaches using the four-section Flashing Yellow Arrow (FYA) vehicle traffic signal as outlined by the NCHRP 3-54 research project for protected-permissive left turn signal displays. Ensure the conflict monitor will operate in the FYA mode and FYAc (Compact) mode as specified below to monitor each channel pair for the following fault conditions: Conflict, Flash Rate Detection, Red Fail, Dual Indication, and Clearance. Provide a switch to select between the FYA mode and FYAc mode. Provide a switch to select each FYA phase movement for monitoring.

FYA mode

| FYA Signal Head | Phase 1 | Phase 3 | Phase 5 | Phase 7 |
|-----------------------|------------------|-------------------|-------------------|-------------------|
| Red Arrow | Channel 9 Red | Channel 10 Red | Channel 11 Red | Channel 12 Red |
| Yellow Arrow | Channel 9 Yellow | Channel 10 Yellow | Channel 11 Yellow | Channel 12 Yellow |
| Flashing Yellow Arrow | Channel 9 Green | Channel 10 Green | Channel 11 Green | Channel 12 Green |
| Green Arrow | Channel 1 Green | Channel 3 Green | Channel 5 Green | Channel 7 Green |

FYAc mode

| FYA Signal Head | Phase 1 | Phase 3 | Phase 5 | Phase 7 |
|-----------------------|------------------|------------------|------------------|-------------------|
| Red Arrow | Channel 1 Red | Channel 3 Red | Channel 5 Red | Channel 7 Red |
| Yellow Arrow | Channel 1 Yellow | Channel 3 Yellow | Channel 5 Yellow | Channel 7 Yellow |
| Flashing Yellow Arrow | Channel 1 Green | Channel 3 Green | Channel 5 Green | Channel 7 Green |
| Green Arrow | Channel 9 Green | Channel 9 Yellow | Channel 10 Green | Channel 10 Yellow |

If a FYA channel pair is enabled for FYA operation, the conflict monitor will monitor the FYA logical channel pair for the additional following conditions:

1. **Conflict:** Channel conflicts are detected based on the permissive programming jumpers on the program card. This operation remains unchanged from normal operation except for the solid Yellow arrow (FYA clearance) signal.
2. **Yellow Change Interval Conflict:** During the Yellow change interval of the Permissive Turn channel (flashing Yellow arrow) the conflict monitor shall verify that no conflicting channels to the solid Yellow arrow channel (clearance) are active. These conflicting channels shall be determined by the program card compatibility programming of the Permissive Turn channel (flashing Yellow arrow). During the Yellow change interval of the Protected Turn channel (solid Green arrow) the conflict monitor shall verify that no conflicting channels to the solid Yellow arrow channel (clearance) are active as determined by the program card compatibility programming of the Protected Turn channel (solid Green arrow).

3. **Flash Rate Detection:** The conflict monitor unit shall monitor for the absence of a valid flash rate for the Permissive turn channel (flashing Yellow arrow). If the Permissive turn channel (flashing Yellow arrow) is active for a period greater than 1600 milliseconds, ensure the conflict monitor triggers and puts the intersection into flash. If the Permissive turn channel (flashing Yellow arrow) is active for a period less than 1400 milliseconds, ensure the conflict monitor does not trigger. Ensure the conflict monitor will remain in the triggered (in fault mode) state until the unit is reset at the front panel or through the external remote reset input. Provide a jumper or switch that will enable and disable the Flash Rate Detection function. Ensure that when the jumper is not present or the switch is in the OFF position the Flash Rate Detection function is enabled. Ensure that when the jumper is present or the switch is in the ON position the Flash Rate Detection function is disabled.
4. **Red Monitoring or Absence of Any Indication (Red Failure):** The conflict monitor unit shall detect a red failure if there is an absence of voltage on all four of the inputs of a FYA channel pair (RA, YA, FYA, GA).
5. **Dual Indications on the Same Channel:** The conflict monitor unit shall detect a dual indication if two or more inputs of a FYA channel pair (RA, YA, FYA, GA) are “on” at the same time.
6. **Short/Missing Yellow Indication Fault (Clearance Error):** The conflict monitor unit shall monitor the solid Yellow arrow for a clearance fault when terminating both the Protected Turn channel (solid Green arrow) interval and the Permissive Turn channel (flashing Yellow arrow) interval.

Ensure that the conflict monitor will log at least nine of the most recent events detected by the monitor in non-volatile EEPROM memory (or equivalent). For each event, record at a minimum the time, date, type of event, status of each field signal indication with RMS voltage, and specific channels involved with the event. Ensure the conflict monitor will log the following events: monitor reset, configuration, previous fault, and AC line. Furnish the signal sequence log that shows all channel states (Greens, Yellows, and Reds) and the Red Enable State for a minimum of 2 seconds prior to the current fault trigger point. Ensure the display resolution of the inputs for the signal sequence log is not greater than 50 ms.

For conflict monitors used within an Ethernet communications system, provide a conflict monitor with an Ethernet 10/100 Mbps, RJ-45 port for data communication access to the monitor by a local notebook computer and remotely via a workstation or notebook computer device connected to the signal system local area network. The Ethernet port shall be electrically isolated from the conflict monitor’s electronics and shall provide a minimum of 1500 Vrms isolation. Integrate monitor with Ethernet network in cabinet. Provide software to retrieve the time and date from a network server in order to synchronize the on-board times between the conflict monitor and the controller. Furnish and install the following Windows based, graphic user interface software on workstations and notebook computers where the signal system client software is installed: 1) software to view and retrieve all event log information, 2) software that will search and display a list of conflict monitor IP addresses and IDs on the network, and 3) software to change the conflict monitor’s network parameters such as IP address and subnet mask.

For non-Ethernet connected monitors, provide a RS-232C/D compliant port (DB-9 female connector) on the front panel of the conflict monitor in order to provide communications from the conflict monitor to the 170/2070 controller or to a Department-furnished laptop computer.

Electrically isolate the port interface electronics from all monitor electronics, excluding Chassis Ground. Ensure that the controller can receive all event log information through a controller Asynchronous Communications Interface Adapter (Type 170E) or Async Serial Comm Module (2070). Furnish and connect a serial cable from the conflict monitor's DB-9 connector to Comm Port 1 of the 2070 controller. Ensure conflict monitor communicates with the controller. Provide a Windows based graphic user interface software to communicate directly through the same monitor RS-232C/D compliant port to retrieve and view all event log information to a Department-furnished laptop computer. The RS-232C/D compliant port on the monitor shall allow the monitor to function as a DCE device with pin connections as follows:

| Conflict Monitor RS-232C/D (DB-9 Female) Pinout | | |
|--|-----------------|------------|
| Pin Number | Function | I/O |
| 1 | DCD | O |
| 2 | TX Data | O |
| 3 | RX Data | I |
| 4 | DTR | I |
| 5 | Ground | - |
| 6 | DSR | O |
| 7 | CTS | I |
| 8 | RTS | O |
| 9 | NC | - |

MONITOR BOARD EDGE CONNECTOR

| Pin # | Function (Back Side) | Pin # | Function (Component Side) |
|--------------|-----------------------------|--------------|----------------------------------|
| 1 | Channel 2 Green | A | Channel 2 Yellow |
| 2 | Channel 13 Green | B | Channel 6 Green |
| 3 | Channel 6 Yellow | C | Channel 15 Green |
| 4 | Channel 4 Green | D | Channel 4 Yellow |
| 5 | Channel 14 Green | E | Channel 8 Green |
| 6 | Channel 8 Yellow | F | Channel 16 Green |
| 7 | Channel 5 Green | H | Channel 5 Yellow |
| 8 | Channel 13 Yellow | J | Channel 1 Green |
| 9 | Channel 1 Yellow | K | Channel 15 Yellow |
| 10 | Channel 7 Green | L | Channel 7 Yellow |
| 11 | Channel 14 Yellow | M | Channel 3 Green |
| 12 | Channel 3 Yellow | N | Channel 16 Yellow |
| 13 | Channel 9 Green | P | Channel 17 Yellow |
| 14 | Channel 17 Green | R | Channel 10 Green |
| 15 | Channel 11 Yellow | S | Channel 11 Green |
| 16 | Channel 9 Yellow | T | Channel 18 Yellow |
| 17 | Channel 18 Green | U | Channel 10 Yellow |
| -- | | -- | |
| 18 | Channel 12 Yellow | V | Channel 12 Green |
| 19 | Channel 17 Red | W | Channel 18 Red |
| 20 | Chassis Ground | X | Not Assigned |
| 21 | AC- | Y | DC Common |
| 22 | Watchdog Timer | Z | External Test Reset |
| 23 | +24VDC | AA | +24VDC |
| 24 | Tied to Pin 25 | BB | Stop Time (Output) |
| 25 | Tied to Pin 24 | CC | Not Assigned |
| 26 | Not Assigned | DD | Not Assigned |
| 27 | Relay Output, Side #3, N.O. | EE | Relay Output,Side #2,Common |
| 28 | Relay Output, Side #1, N.C. | FF | AC+ |

-- Slotted for keying between Pins 17/U and 18/V

CONFLICT PROGRAM CARD PIN ASSIGNMENTS

| Pin # | Function (Back Side) | Pin # | Function (Component Side) |
|--------------|-----------------------------|--------------|----------------------------------|
| 1 | Channel 2 Green | A | Channel 1 Green |
| 2 | Channel 3 Green | B | Channel 2 Green |
| 3 | Channel 4 Green | C | Channel 3 Green |
| 4 | Channel 5 Green | D | Channel 4 Green |
| 5 | Channel 6 Green | E | Channel 5 Green |
| 6 | Channel 7 Green | F | Channel 6 Green |
| 7 | Channel 8 Green | H | Channel 7 Green |
| 8 | Channel 9 Green | J | Channel 8 Green |
| 9 | Channel 10 Green | K | Channel 9 Green |
| 10 | Channel 11 Green | L | Channel 10 Green |
| 11 | Channel 12 Green | M | Channel 11 Green |
| 12 | Channel 13 Green | N | Channel 12 Green |
| 13 | Channel 14 Green | P | Channel 13 Green |
| 14 | Channel 15 Green | R | Channel 14 Green |
| 15 | Channel 16 Green | S | Channel 15 Green |
| 16 | N/C | T | PC AJAR |
| 17 | Channel 1 Yellow | U | Channel 9 Yellow |
| 18 | Channel 2 Yellow | V | Channel 10 Yellow |
| 19 | Channel 3 Yellow | W | Channel 11 Yellow |
| 20 | Channel 4 Yellow | X | Channel 12 Yellow |
| 21 | Channel 5 Yellow | Y | Channel 13 Yellow |
| 22 | Channel 6 Yellow | Z | Channel 14 Yellow |
| 23 | Channel 7 Yellow | AA | Channel 15 Yellow |
| 24 | Channel 8 Yellow | BB | Channel 16 Yellow |
| -- | | -- | |
| 25 | Channel 17 Green | CC | Channel 17 Yellow |
| 26 | Channel 18 Green | DD | Channel 18 Yellow |
| 27 | Channel 16 Green | EE | PC AJAR (Program Card) |
| 28 | Yellow Inhibit Common | FF | Channel 17 Green |

-- Slotted for keying between Pins 24/BB and 25/CC

- MODEL 2070-1E, CPU Module, Single Board, with 8Mb Datakey (blue in color)
- MODEL 2070-2A or approved MODEL 2070-2E, Field I/O Module (FI/O)
 - Note: Configure the Field I/O Module to disable both the External WDT Shunt/Toggle Switch and SP3 (SP3 active indicator is “off”)
- MODEL 2070-3B, Front Panel Module (FP), Display B (8x40)
- MODEL 2070-4, Power Supply Module, 10 AMP
- MODEL 2070-7A, Async Serial Com Module (9-pin RS-232)

Furnish one additional MODEL 2070-7A, Async Serial Com Module (9-pin RS-232) for all master controller locations.

For each master location and central control center, furnish a U.S. Robotics V.92 or approved equivalent auto-dial/auto-answer external modem to accomplish the interface to the Department-furnished microcomputers. Include all necessary hardware to ensure telecommunications.

Project Special Provisions
Structures

Table of Contents

| | Page # |
|---|-------------------|
| Maintenance & Protection of Traffic Beneath | |
| Proposed Structure (Special) | ----- ST-2 |
| Placing Load on Structure Members (11-27-12) | ----- ST-3 |
| Electrical Conduit System for Signals (9-30-11) | ----- ST-3 |
| Steel Reinforced Elastomeric Bearings (6-22-16) | ----- ST-7 |
| Thermal Sprayed Coatings (Metallization) (9-30-11) | ----- ST-7 |
| Sand Lightweight Concrete (9-30-11) | ----- ST-11 |
| Expansion Joint Seals (9-30-11) | ----- ST-12 |
| Falsework and Formwork (4-5-12) | ----- ST-15 |
| Submittal of Working Drawings (6-19-15) | ----- ST-22 |
| Crane Safety (8-15-05) | ----- ST-28 |
| Grout for Structures (9-30-11) | ----- ST-29 |
| Embedded Clips for Prestressed Concrete Girders (6-22-16) | ----- ST-31 |
| 2 Bar Metal Rail Retrofit (Special) | ----- ST-31 |
| Norfolk Southern Railroad Provisions | ----- ST-32 |
| Railroad Site Data | ----- ST-57 |

For Piles, see Geotechnical special provisions.

For MSE Retaining Walls, see Geotechnical special provisions.

For Segmental Retaining Walls, see Geotechnical special provisions.



4/13/2017

DocuSigned by:

 A4A2999A8BC64F2...

ST-2

Project U-3109A

Alamance County

PROJECT SPECIAL PROVISIONS **STRUCTURES**

MAINTENANCE AND PROTECTION OF TRAFFIC **BENEATH PROPOSED STRUCTURE**

(SPECIAL)

1.0 GENERAL

Maintain traffic on the travelways listed in Table 1 as shown in Traffic Control Plans and as directed by the Engineer.

Provide a minimum temporary vertical clearance as shown in Table 1 at all times during construction.

Table 1

| Station | Travelway | Min Vertical Clearance |
|---------------------|--|------------------------|
| 26+54.73 -NBL- | I40-85 | 16'-6" |
| 146+61.35 -L- (SBL) | US70, Holt Street and Norfolk Southern Railroad | 23'-6" |
| 146+61.35 -L- (NBL) | US70, Holt Street and Norfolk Southern Railroad | 23'-6" |

Submit plans and calculations for review and approval for protecting traffic and bracing girders, as described herein, at the above station before beginning work at this location. Have the drawings and design calculations prepared, signed, and sealed by a North Carolina Registered Professional Engineer. The approval of the Engineer will not relieve the Contractor of the responsibility for the safety of the method or equipment.

2.0 PROTECTION OF TRAFFIC

Protect traffic from any operation that affords the opportunity for construction materials, equipment, tools, etc. to be dropped into the path of traffic beneath the structure. Based on Contractor means and methods determine and clearly define all dead and live loads for this system, which, at a minimum, shall be installed between beams or girders over any travelway or shoulder area where traffic is maintained. Install the protective system before beginning any construction operations over traffic. In addition, for these same areas, keep the overhang falsework in place until after the rails have been poured.

3.0 BRACING GIRDERS

Brace girders to resist wind forces, weight of forms and other temporary loads, especially those eccentric to the vertical axis of the member during all stages of erection and

ST-3

Project U-3109A

Alamance County

construction. Before casting of intermediate diaphragms, decks, or connecting steel diaphragms do not allow the horizontal movement of girders to exceed ½ inch.

4.0 BASIS OF PAYMENT

Payment at the contract unit prices for the various pay items will be full compensation for the above work.

PLACING LOAD ON STRUCTURE MEMBERS

(11-27-12)

The 2012 Standard Specifications shall be revised as follows:

In **Section 420-20 – Placing Load on Structure Members** replace the first sentence of the fifth paragraph with the following:

Do not place vehicles or construction equipment on a bridge deck until the deck concrete develops the minimum specified 28 day compressive strength and attains an age of at least 7 curing days.

ELECTRICAL CONDUIT SYSTEM FOR SIGNALS

(9-30-11)

GENERAL

The work covered by this section consists of furnishing and installing a conduit system suspended beneath structures and buried. Perform all work in accordance with these special provisions, the plans, and the National Electrical Code (NEC). Install the conduit system in accordance with NEC requirements as an approved raceway for electrical circuits.

The Contractor actually performing the work described in these special provisions is required to have a license of the proper classification from the North Carolina State Board of Examiners of Electrical Contractors.

The licensed Electrical Contractor is required to be available on the job site when the work is being performed or when requested by the Engineer. The licensed Electrical Contractor is required to have a set of plans and special provisions in his possession on the job site, and must maintain accurate “as built” plans.

MATERIALS

Submit eight (8) copies of catalog cuts and/or drawings for all proposed materials for the Engineer’s review and approval. Include the brand name, stock number, description, size, rating, manufacturing specification, and applicable contract item number(s) on each submittal. Allow forty (40) days for submittal review. The Engineer will advise the Contractor of reasons for rejected submittals and will return approved submittals to the Contractor. Do not deliver material to the project prior to submittal approval.

ST-4

Project U-3109A

Alamance County

For the work covered by this section, the term conduit applies to a system of components consisting of an outer duct, 4 inner ducts, internal spacers, special-purpose spin couplings and all necessary components, referred to as a multi-cell raceway system.

For the outer duct of RGC multi-cell raceway, use rigid galvanized conduit per UL 6 “Rigid Metallic Conduit” with rigid full weight galvanized threaded fittings. Provide factory installed reverse-spin couplings with 3 set screws, to allow assembly without turning the outer duct, and prevent the coupling from backing off before and after installation. Provide an O-ring gasket in the coupling body to resist pullout and to create a watertight seal. Provide pre-installed, smooth walled, pre-lubricated PVC inner ducts, with one white “tracer” duct and internal spacers to maintain alignment throughout the raceway system. Do not use materials provided by more than one manufacturer.

When deflection couplers are detailed on the plans, use deflection couplers that are designed for use with RGC multi-cell raceway, and meet all the requirements for RGC outer duct stated above. Provide deflection couplers that allow a 30 degree bend in any direction and ¾ inch mis-alignment in all axis. Provide factory installed reverse-spin couplings with 3 set screws, to allow assembly without turning the outer duct, and prevent the coupling from backing off before and after installation. Provide deflection couplers with a middle section consisting of a rubber boot attached by spin couplings and galvanized straps, with inner ducts that bend in unison with the rubber boot.

Use expansion joints that are designed for use with RGC multi-cell raceway, and meet the requirements for RGC outer duct stated above. Provide expansion joints that allow 8 inches of longitudinal movement. Use expansion joints consisting of a female end with a lead-in coupling body and spin coupling, an exterior sliding joint, and a fixed inner duct with an internal sliding joint. Provide expansion joints that have factory installed reverse-spin couplings with 3 set screws, to allow assembly without turning the outer duct and prevent the coupling from backing off before and after installation.

Use transition adapters that allow RGC raceway and PVC raceway to be coupled together while maintaining the same inner duct alignment. Provide adapters consisting of a threaded female adapter, an outer duct adapter, and a modified coupling body with a sleeve, thin wall couplings and an end spacer.

For the outer duct of PVC multi-cell raceway use schedule 40 PVC per UL 651 “Rigid Nonmetallic Conduit.” Use PVC raceway with 6 inch bell ends and an O-ring gasket to resist pullout and provide a watertight seal. Provide PVC raceway having a print line that states “Install Print Line Up” to help facilitate correct installation. Use PVC raceway with pre-lubricated PVC inner ducts, with one white “tracer” duct and internal spacers to maintain alignment throughout the raceway system. Do not use material provided by more than one manufacturer.

Use terminations designed for PVC raceway, to seal each inner duct and the outer duct, and to provide watertight protection.

Use schedule 40 PVC for sleeves in accordance with UL 651 “Rigid Nonmetallic Conduit.”

ST-5

Project U-3109A

Alamance County

Provide concrete inserts made of galvanized malleable iron, with internal threads for suspending loads from a fixed point beneath a concrete ceiling or deck where no lateral adjustment is required. Use inserts that can be secured to the concrete forms, preventing movement during concrete placement.

For stabilizers and hangers, use galvanized rods that conform to ASTM-A36 or A-575. Galvanized rods may be threaded on both ends or threaded continuously. Use steel stabilizer clamps and attachment brackets, sized as noted in the plans and hot dipped galvanized per ASTM-A123. Provide high strength bolts, nuts and washers that are galvanized in accordance with Article 1072-5 of the Standard Specifications.

Use adjustable clevis-type pipe hangers that allow for vertical adjustment and limited movement of the pipe. Use galvanized pipe hangers that are listed with Underwriters Laboratories, or are Factory Mutual approved for the size conduit shown in the plans. Use hangers that comply with Federal Specification WW-H-171E Type 1 and Manufacturers Standardization Society SP-69 Type 1. Plastic-coat the saddle area of the hanger.

Provide pull lines specifically designed for pulling rope through conduit. Use pull lines made of 2-ply line, with a tensile strength of 240 pounds minimum. Use rot and mildew resistant pull lines that are resistant to tangling when being dispensed.

Use mastic that is a permanent, non-hardening, water sealing compound that adheres to metal, plastic, and concrete.

Provide jute that is a burlap-like material used for filling voids and protecting components from waterproofing and adhesive compounds.

Provide zinc rich paint conforming to Section 1080-9 of the Standard Specifications.

INSTALLATION

To ensure against corrosion in the area where hot dipped galvanizing has been damaged, cover all raw metal surfaces with a cold galvanized, zinc rich paint.

Stub the raceway out at an accessible location and seal with termination kits designed specifically for that purpose. Use termination kits of the same material as the raceway.

Install Stabilizers as shown on the plans to assure proper movement of the conduit expansion joints. Securely fasten the clamps with attachment brackets and stabilizer rods to the conduit at the indicated locations to assure these locations remain stationary. Install the stabilizer rods parallel to the alignment of the conduit, and tilt rod upward at an orientation of 45 degrees to the bottom of the bridge deck.

Insert a pull line in each inner duct with sufficient slack for future use.

Securely fasten all components to prevent movement during concrete placement.

ST-6

Project U-3109A

Alamance County

Smooth all sleeve ends and make them flush with surrounding concrete surfaces. Remove burrs and rough edges by filing or grinding. A torch may be used to cut the ends of metal sleeves. Use shields to protect all surfaces during torch-cutting operations.

Place backfill in accordance with Section 300-7 of the Standard Specifications.

Fill the space between the raceway and the sleeve with mastic and jute. Install the mastic with a minimum distance of 2 inches at each end of the sleeve and the remaining interior space filled with jute. Finish the mastic by making it smooth and flush with the concrete.

Coordinate electrical conduit system work with work by others, and allow installation of circuitry or fiber optic cables during the construction process as directed by the Engineer.

Ensure that the concrete inserts are in the proper position and installed correctly, including when they are located in prestressed concrete deck panels.

Keep the raceway system clean of all debris during construction, with the completed system clean and ready for installation of circuitry or fiber optic cables.

The Engineer must inspect and approve all work before concealment.

BASIS OF PAYMENT

No direct measurement will be made for the conduit system, since it will be paid for on a lump sum basis.

Payment for the conduit system will be made at the contract lump sum price for "Electrical Conduit System for Signals at station 146+61.35 -L-".

Such price and payment for the conduit system as provided above will be considered full compensation for all materials, equipment, and labor necessary to complete the work in accordance with the plans and these special provisions.

Payment will be made under:

Electrical Conduit System for Signals at station 146+61.35 -L- _____ Lump Sum

ST-7

Project U-3109A

Alamance County

STEEL REINFORCED ELASTOMERIC BEARINGS

(6-22-16)

The 2012 Standard Specifications shall be revised as follows:

In **Section 1079-2(A) – Elastomeric Bearings** add the following after the second paragraph:

Internal holding pins are required for all shim plates when the contract plans indicate the structure contains the necessary corrosion protection for a corrosive site.

Repair laminated (reinforced) bearing pads utilizing external holding pins via vulcanization. Submit product data for repair material and a detailed application procedure to the Materials and Tests Unit for approval before use and annually thereafter.

THERMAL SPRAYED COATINGS (METALLIZATION)

(9-30-11)

DESCRIPTION

Apply a thermal sprayed coating (TSC) and sealer to metal surfaces as specified herein when called for on the plans or by other Special Provisions, or when otherwise approved by the Engineer in accordance with the SSPC-CS 23.00/AWS C2.23/NACE No. 12 Specification. Only Arc Sprayed application methods are used to apply TSC coatings, the Engineer must approve other methods of application.

QUALIFICATIONS

Only use NCDOT approved TSC Contractors meeting the following requirements:

1. The capability of blast cleaning steel surfaces to SSPC SP-5 and SP-10 Finishes.
2. Employ Spray Operator(s) qualified in accordance with AWS C.16/C2.16M2002 and Quality Control Inspector(s) who have documented training in the applicable test procedures of ASTM D-3276 and SSPC-CS 23.00.

A summary of the contractor's related work experience and the documents verifying each Spray Operator's and Quality Control Inspector's qualifications are submitted to the Engineer before any work is performed.

MATERIALS

Provide wire in accordance with the metallizing equipment manufacturer's recommendations. Use the wire alloy specified on the plans which meets the requirements in Annex C of the SSPC-CS 23.00 Specification. Have the contractor provide a certified analysis (NCDOT Type 2 Certification) for each lot of wire material.

Apply an approved sealer to all metallized surfaces in accordance with Section 9 of SSPC-CS 23. The sealer must either meet SSPC Paint 27 or is an alternate approved by the Engineer.

ST-8

Project U-3109A

Alamance County

SURFACE PREPARATION AND TSC APPLICATION

Grind flame cut edges to remove the carbonized surface prior to blasting. Bevel all flame cut edges in accordance with Article 442-10(D) regardless of included angle. Blast clean surfaces to be metallized with grit or mineral abrasive in accordance with Steel Structures Painting Council SSPC SP-5/10(as specified) to impart an angular surface profile of 2.5 - 4.0 mils. Surface preparation hold times are in accordance with Section 7.32 of SSPC-CS 23. If flash rusting occurs prior to metallizing, blast clean the metal surface again. Apply the thermal sprayed coating only when the surface temperature of the steel is at least 5°F above the dew point.

At the beginning of each work period or shift, conduct bend tests in accordance with Section 6.5 of SSPC-CS 23.00. Any disbonding or delamination of the coating that exposes the substrate requires corrective action, additional testing, and the Engineer's approval before resuming the metallizing process.

Apply TSC with the alloy to the thickness specified on the plans or as provided in the table below. All spot results (the average of 3 to 5 readings) must meet the minimum requirement. No additional tolerance (as allowed by SSPC PA-2) is permitted. (For Steel Beams: For pieces with less than 200 ft² measure 2 spots/surface per piece and for pieces greater than 200 ft² add 1 additional spots/surface for each 500 ft²).

| Application | Thickness | Alloy | Seal Coat |
|------------------------|------------------|------------------------|------------------|
| Pot Bearings | 8 mil | 85/15 Zinc (W-Zn-Al-2) | 0.5 mil |
| Armored Joint Angles | 8 mil | 85/15 Zinc (W-Zn-Al-2) | 0.5 mil |
| Modular Joints | 8 mil | 99.99% Zn (W-Zn-1) | 0.5 mil |
| Expansion Joint Seals | 8 mil | 99.99% Zn (W-Zn-1) | 0.5 mil |
| Optional Disc Bearings | 8 mil | 85/15 Zinc (W-Zn-Al-2) | 0.5 mil |

When noted on the plans or as specified in the above chart, apply the sealer to all metallized surfaces in accordance with the manufacturer's recommendations and these provisions. Apply the seal coat only when the air temperature is above 40°F and the surface temperature of the steel is at least 5°F above the dew point. If the sealer is not applied within eight hours after the final application of TSC, the applicator verifies acceptable TSC surfaces and obtains approval from the Engineer before applying the sealer.

ST-9

Project U-3109A

Alamance County

INSPECTION FREQUENCY

The TSC Contractor must conduct the following tests at the specified frequency and the results documented in a format approved by the Engineer.

| Test/Standard | Location | Frequency | Specification |
|--|---------------------------------|--|---|
| Ambient Conditions | Site | Each Process | 5°F above the dew point |
| Abrasive Properties | Site | Each Day | Size, angularity, cleanliness |
| Surface Cleanliness SSPC Vis 1 | All Surfaces | Visual All Surfaces | SSPC-SP-10 Atmospheric Service SSPC-SP - 5 Immersion Service |
| Surface Profile ASTM D-4417 Method C | Random Surfaces | 3 per 500 ft ² | 2.5 - 4.0 mils |
| Bend Test SSPC-CS 23.00 | Site | 5 per shift | Pass Visual |
| Thickness SSPC PA-2R SSPC-CS 23.00 | Each Surface | Use the method in PA-2 Appendix 3 for Girders and Appendix 4 for frames and miscellaneous steel. See Note 1. | Zn - 8 mils minimum Al - 8 mils minimum Zn Al - 8 mils minimum Areas with more than twice the minimum thickness are inspected for compliance to the adhesion and cut testing requirements of this specification. |
| Adhesion ASTM 4541 | Random Surfaces Splice Areas | 1 set of 3 per 500 ft ² | Zn > 500 psi Al > 1000 psi Zn Al > 750 psi |
| Cut Test - SSPC-CS 23.00 | Random Surfaces | 3 sets of 3 per 500 ft ² | No peeling or delamination |
| Job Reference Std. SSPC-CS 23.00 | Site | 1 per job | Meets all the above requirements |

REPAIRS

All Repairs are to be performed in accordance with the procedures below, depending on whether the repair surface is hidden or exposed. As an exception to the following, field welded splices on joint angles and field welding bearing plates to girders may be repaired in accordance with the procedures for hidden surfaces.

ST-10

Project U-3109A

Alamance County

For hidden surfaces (including but not limited to interior girders, interior faces of exterior girders, and below-grade sections of piles):

1. Welding of metallized surfaces may be performed only if specifically permitted by the Engineer. Remove metallizing at the location of field welds by blast cleaning (SSPC SP-6 finish), or hand (SSPC SP-2 finish) or power tool cleaning (SSPC SP-3 finish) just prior to welding. Clean sufficiently to prevent contamination of the weld. All repairs to welded connections are metallized in accordance with SSPC CS 23.00.
2. Minor areas less than or equal to 0.1 ft^2 exposing the substrate are metallized in accordance with SSPC CS 23.00 or painted in accordance with ASTM A780, "Repair of Damaged and Uncoated Areas of Hot Dip Galvanized Coatings."
3. Large areas greater than 0.1 ft^2 exposing the substrate are metallized in accordance with SSPC CS 23.00.
4. Damaged (burnished) areas not exposing the substrate with less than the specified coating thickness are metallized in accordance with SSPC CS 23.00 or painted in accordance with ASTM A780, "Repair of Damaged and Uncoated Areas of Hot Dip Galvanized Coatings."
5. Damaged (burnished) areas not exposing the substrate with more than the specified coating thickness are not repaired.
6. Defective coating is repaired by either method 2 or 3 depending on the area of the defect.

For Exposed Surfaces (including but not limited to exterior faces of exterior girders and above-grade sections of piles):

1. Welding of metallized surfaces may be performed only if specifically permitted by the Engineer. Remove metallization at the location of field welds by blast cleaning (SSPC SP-6 finish), or hand (SSPC SP-2 finish) or power tool cleaning (SSPC SP-3 finish) just prior to welding. Clean sufficiently to prevent contamination of the weld. All repairs to welded connections are metallized in accordance with SSPC CS 23.00.
2. All areas exposing the substrate are metallized in accordance with SSPC CS 23.00
3. Defective coating is repaired by either method 2 or 3 depending on the area of the defect.

TWELVE MONTH OBSERVATION PERIOD

The contractor maintains responsibility for the coating system for a twelve (12) month observation period beginning upon the satisfactory completion of all the work required in the plans or as directed by the engineer. The contractor must guarantee the coating system under the payment and performance bond (refer to Article 109-10). To successfully complete the observation period, the coating system must meet the following requirements after twelve(12) months service:

- No visible rust, contamination or application defect is observed in any coated area.

ST-11

Project U-3109A

Alamance County

- Painted surfaces have a uniform color and gloss.
- Surfaces have an adhesion of no less than 500 psi when tested in accordance with ASTM D-4541.

BASIS OF PAYMENT

The contract price bid for the bridge component to which the coating is applied will be full compensation for the thermal sprayed coating.

SAND LIGHTWEIGHT CONCRETE

(9-30-11)

Use sand lightweight concrete, as noted on the plans, that meets the requirements of this Special Provision.

Sand lightweight concrete is composed of portland cement, fine aggregate, lightweight coarse aggregate, water, and admixtures. Provide sand lightweight concrete that complies with the applicable requirements of Sections 420, 1000, and 1024 of the Standard Specifications and the additional requirements herein.

Submit a mix design from a testing laboratory approved by the NC Division of Highways for approval at least 35 days prior to the proposed use. Provide a mix meeting Table 1000-1 of the Standard Specifications and the following design criteria:

| TEST | TEST METHOD | REQUIREMENT |
|--|---|-------------|
| Max. Unit Weight, plastic, lbs/ft ³ | AASHTO T121 | 120 |
| Max. Unit Weight, dry, lbs/ft ³ | ASTM C567 using equilibrium air dried unit weight | 115 |
| Min. Relative Dynamic Modulus, (percent) | AASHTO T161 Procedure A | 80 |

When submitting the mix design, include the source of the aggregates, cement, and admixtures and the gradation, specific gravity and fineness modulus (fine aggregate only) of the aggregates. Submit test results showing the mix design conforms to the criteria, including the 28 day compressive strength of a minimum of six cylinders. Provide a mix design that produces an average compressive strength sufficient to ensure that a minimum strength of 4500 psi is achieved in the field.

Produce an additional mix in accordance with AASHTO M195 to determine the drying shrinkage. The maximum drying shrinkage for this mix is 0.07%.

For lightweight aggregate, use expanded shale or slate that meets the requirements of AASHTO M195. Grade the lightweight aggregate in accordance with 1014-2(E)(6).

Determine the soundness in accordance with AASHTO T104. Loss of more than 10% of the lightweight aggregate in five cycles of the accelerated soundness test using sodium sulfate is not permitted.

Ensure the lightweight aggregate is in a saturated surface-dry condition when it is proportioned and incorporated into the mix.

EXPANSION JOINT SEALS

(9-30-11)

1.0 GENERAL

The work covered by this Special Provision consists of furnishing and installing the expansion joint seals as shown on the contract drawings. All materials, labor, equipment and incidentals necessary for the proper installation of the expansion joint seals are included.

2.0 MATERIAL

Provide expansion joint seals capable of accommodating a total movement measured parallel to the centerline of the roadway as shown on plans.

Provide an elastomeric component for each expansion joint seal that is a continuous unit for the entire length of the joint. Do not field splice the elastomeric component. Only vulcanized shop splicing of the elastomeric component is permitted. The minimum length of an elastomeric component before shop splicing is 20 feet. However, one piece shorter than 20 feet is permitted. Provide an elastomeric component that is clearly shop marked to indicate the top side and joint location of the elastomeric component. On skewed bridges, or under unsymmetrical conditions, clearly mark the left side of the elastomeric component. Left is defined as being on the left when facing in the direction of increasing station. Inspect the seals upon receipt to ensure that the marks are clearly visible upon installation.

Make sure the convolution of the gland does not project above the top of the hold-down plates when the joint opening is in the most compressed condition. Use either elastic polychloroprene (neoprene) or ethyl propylene diene monomer (EPDM) for the elastomer that meets the following minimum properties:

ST-13

| | ASTM TEST METHOD | REQUIREMENTS |
|-------------------------------------|------------------|---|
| Hardness, Durometer - Shore A | D2240 | 60 ± 5, Neoprene (upward corrugated shape - fabric reinforced) 75 ± 5, EPDM and Neoprene (upward non-corrugated shape) 80 ± 5, EPDM (upward corrugated shape-fabric reinforced) |
| Tensile Strength | D412 | 2000 psi (min.) |
| Elongation at Break | D412 | 250% (min.) |
| Width of Gland in Relaxed Condition | N/A | 10" ± 0.25" |

| | | |
|--|-----|--|
| Thickness of Upturned portion of gland | N/A | 0.25" non-corrugated shape, -0.032" to +0.032" |
| Thickness of Upturned portion of gland | N/A | 0.1875" corrugated shape, -0.032" to +0.032" |
| Thickness of Flat portion of gland | N/A | 0.1563", -0.032" to +0.032" |

For fabric reinforced glands, submit one unreinforced sample per lot number, up to 500 feet of Expansion Joint Seal, to the Engineer for testing.

Only field splice hold-down plates at crown points, at abrupt changes in the deck slab cross slope, and on lane lines. Splicing within travel lanes is not permitted and splicing on edge lines is not required. Field splice hold-down plates between the edge line and gutter upturn and where necessary for proper installation and alignment is permitted. Show all splice locations on the working drawings for approval. For the location of lane markings at the expansion joint seal, see the Structure plans. At the splice locations, locate the hold-down bolts 3 inches from the end of the hold-down plate. At splice locations where changes in deck slab cross slope occur, cut the ends of hold-down plates parallel to the bridge centerline for skewers less than 80° and greater than 100°.

Do not use welded shop splices in hold-down plates.

3.0 SHOP DRAWINGS

Submit nine sets of working drawings to the Engineer for review, comments and acceptance. Show complete details drawn to scale and include:

- The proposed template details including the makeup of the template

ST-14

Project U-3109A

Alamance County

- The proposed method of holding the base angle assembly in place while concrete is cast around it
- The proposed procedure to correct for the effects of beam movement and rotation when setting width of joint opening
- The proposed chronology of installation including the sequence and direction of the concrete casting
- The details of cross connectors between base angles, such as steel bars with slots bolted to angles, to maintain evenness between the adjacent base angles while accommodating movement that occurs when concrete is cast. Indicate when bolts are loosened to allow movement.
- The proposed method for removing the hold-down plate
- A section detail through the joint showing horizontal offset dimensions of the base angles from the centerline joint. This detail is required when the vertical face of the joint opening is not perpendicular to the roadway surface (e.g. when the roadway grade is significant).

Have someone other than the one who prepares the drawing check all detailed drawings and include the signatures of both the drafter and checker on each sheet of the drawings. The Engineer returns unchecked drawings to the Contractor. Provide all completed drawings well in advance of the scheduled installation time for the expansion joint seal.

4.0 INSTALLATION

Provide supports for the base angle assembly at a maximum spacing of 9 feet. Place supports near field splices of base angles to ensure that field splices are straight and even. Provide base angles with ½" diameter weep holes at 12 inch centers to allow bleeding of trapped air and/or water. Do not obstruct the weep holes with falsework. Make the bottom of the trough parallel to grade and the sides parallel to the sides of the expansion joint seal.

For damaged areas, depressions, spalls, cracks, or irregularities of curbs or decks adjacent to the expansion joint, submit a proposed method of repair and repair material specifications for approval.

If the Engineer deems any aspects of the expansion joint seals unacceptable, make necessary corrections.

5.0 INSPECTION

When concrete is cast, use a non-aluminum, 10 foot, true to line straight edge to check and grade the top of the slab on each side of the joint to ensure smooth transition between spans.

Watertight Integrity Test

- Upon completion of an expansion joint seal, perform a water test on the top surface to detect any leakage. Cover the roadway section of the joint from curb to curb, or barrier rail to barrier rail, with water, either ponded or flowing, not less than 1 inch

above the roadway surface at all points. Block sidewalk sections and secure an unnozzled water hose delivering approximately 1 gallon of water per minute to the inside face of the bridge railing, trained in a downward position about 6 inches above the sidewalks, such that there is continuous flow of water across the sidewalk and down the curb face of the joint.

- Maintain the ponding or flowing of water on the roadway and continuous flow across sidewalks and curbs for a period of 5 hours. At the conclusion of the test, the underside of the joint is closely examined for leakage. The expansion joint seal is considered watertight if no obvious wetness is visible on the Engineer's finger after touching a number of underdeck areas. Damp concrete that does not impart wetness to the finger is not a sign of leakage.
- If the joint system leaks, locate the place(s) of leakage and take any repair measures necessary to stop the leakage at no additional cost to the Department. Use repair measures recommended by the manufacturer and approved by the Engineer prior to beginning corrective work.
- If measures to eliminate leakage are taken, perform a subsequent water integrity test subject to the same conditions as the original test. Subsequent tests carry the same responsibility as the original test and are performed at no extra cost to the Department.

6.0 BASIS OF PAYMENT

Basis of payment for all expansion joint seals will be at the lump sum contract price for "Expansion Joint Seals" which price and payment will be full compensation for furnishing all material, including any steel accessory plates for sidewalks, medians and rails, labor, tools, and incidentals necessary for installing the expansion joint seal in place and including all materials, labor, tools and incidentals for performing the original watertight integrity test.

FALSEWORK AND FORMWORK

(4-5-12)

1.0 DESCRIPTION

Use this Special Provision as a guide to develop temporary works submittals required by the Standard Specifications or other provisions; no additional submittals are required herein. Such temporary works include, but are not limited to, falsework and formwork.

Falsework is any temporary construction used to support the permanent structure until it becomes self-supporting. Formwork is the temporary structure or mold used to retain plastic or fluid concrete in its designated shape until it hardens. Access scaffolding is a temporary structure that functions as a work platform that supports construction personnel, materials, and tools, but is not intended to support the structure. Scaffolding systems that are used to

ST-16

Project U-3109A

Alamance County

temporarily support permanent structures (as opposed to functioning as work platforms) are considered to be falsework under the definitions given. Shoring is a component of falsework such as horizontal, vertical, or inclined support members. Where the term “temporary works” is used, it includes all of the temporary facilities used in bridge construction that do not become part of the permanent structure.

Design and construct safe and adequate temporary works that will support all loads imposed and provide the necessary rigidity to achieve the lines and grades shown on the plans in the final structure.

MATERIALS

Select materials suitable for temporary works; however, select materials that also ensure the safety and quality required by the design assumptions. The Engineer has authority to reject material on the basis of its condition, inappropriate use, safety, or nonconformance with the plans. Clearly identify allowable loads or stresses for all materials or manufactured devices on the plans. Revise the plan and notify the Engineer if any change to materials or material strengths is required.

DESIGN REQUIREMENTS

A. Working Drawings

Provide working drawings for items as specified in the contract, or as required by the Engineer, with design calculations and supporting data in sufficient detail to permit a structural and safety review of the proposed design of the temporary work.

On the drawings, show all information necessary to allow the design of any component to be checked independently as determined by the Engineer.

When concrete placement is involved, include data such as the drawings of proposed sequence, rate of placement, direction of placement, and location of all construction joints. Submit the number of copies as called for by the contract.

When required, have the drawings and calculations prepared under the guidance of, and sealed by, a North Carolina Registered Professional Engineer who is knowledgeable in temporary works design.

If requested by the Engineer, submit with the working drawings manufacturer’s catalog data listing the weight of all construction equipment that will be supported on the temporary work. Show anticipated total settlements and/or deflections of falsework and forms on the working drawings. Include falsework footing settlements, joint take-up, and deflection of beams or girders.

As an option for the Contractor, overhang falsework hangers may be uniformly spaced, at a maximum of 36 inches, provided the following conditions are met:

ST-17

Project U-3109A

Alamance County

| Member Type (PCG) | Member Depth, (inches) | Max. Overhang Width, (inches) | Max. Slab Edge Thickness, (inches) | Max. Screenshot Wheel Weight, (lbs.) | Bracket Min. Vertical Leg Extension, (inches) |
|-------------------|------------------------|-------------------------------|------------------------------------|--------------------------------------|---|
| II | 36 | 39 | 14 | 2000 | 26 |
| III | 45 | 42 | 14 | 2000 | 35 |
| IV | 54 | 45 | 14 | 2000 | 44 |
| MBT | 63 | 51 | 12 | 2000 | 50 |
| MBT | 72 | 55 | 12 | 1700 | 48 |

Overhang width is measured from the centerline of the girder to the edge of the deck slab.

For Type II, III & IV prestressed concrete girders (PCG), 45-degree cast-in-place half hangers and rods must have a minimum safe working load of 6,000 lbs.

For MBT prestressed concrete girders, 45-degree angle holes for falsework hanger rods shall be cast through the girder top flange and located, measuring along the top of the member, 1'-2½" from the edge of the top flange. Hanger hardware and rods must have a minimum safe working load of 6,000 lbs.

The overhang bracket provided for the diagonal leg shall have a minimum safe working load of 3,750 lbs. The vertical leg of the bracket shall extend to the point that the heel bears on the girder bottom flange, no closer than 4 inches from the bottom of the member. However, for 72-inch members, the heel of the bracket shall bear on the web, near the bottom flange transition.

Provide adequate overhang falsework and determine the appropriate adjustments for deck geometry, equipment, casting procedures and casting conditions.

If the optional overhang falsework spacing is used, indicate this on the falsework submittal and advise the girder producer of the proposed details. Failure to notify the Engineer of hanger type and hanger spacing on prestressed concrete girder casting drawings may delay the approval of those drawings.

Falsework hangers that support concentrated loads and are installed at the edge of thin top flange concrete girders (such as bulb tee girders) shall be spaced so as not to exceed 75% of the manufacturer's stated safe working load. Use of dual leg hangers (such as Meadow Burke HF-42 and HF-43) are not allowed on concrete girders with thin top flanges. Design the falsework and forms supporting deck slabs and overhangs on girder bridges so that there will be no differential settlement between the girders and the deck forms during placement of deck concrete.

When staged construction of the bridge deck is required, detail falsework and forms for screed and fluid concrete loads to be independent of any previous deck pour components when the mid-span girder deflection due to deck weight is greater than ¾".

ST-18

Project U-3109A

Alamance County

Note on the working drawings any anchorages, connectors, inserts, steel sleeves or other such devices used as part of the falsework or formwork that remains in the permanent structure. If the plan notes indicate that the structure contains the necessary corrosion protection required for a Corrosive Site, epoxy coat, galvanize or metalize these devices. Electroplating will not be allowed. Any coating required by the Engineer will be considered incidental to the various pay items requiring temporary works.

Design falsework and formwork requiring submittals in accordance with the 1995 AASHTO *Guide Design Specifications for Bridge Temporary Works* except as noted herein.

Wind Loads

Table 2.2 of Article 2.2.5.1 is modified to include wind velocities up to 110 mph. In addition, Table 2.2A is included to provide the maximum wind speeds by county in North Carolina.

Table 2.2 - Wind Pressure Values

| Height Zone feet above ground | Pressure, lb/ft ² for Indicated Wind Velocity, mph | | | | |
|----------------------------------|---|----|----|-----|-----|
| | 70 | 80 | 90 | 100 | 110 |
| 0 to 30 | 15 | 20 | 25 | 30 | 35 |
| 30 to 50 | 20 | 25 | 30 | 35 | 40 |
| 50 to 100 | 25 | 30 | 35 | 40 | 45 |
| over 100 | 30 | 35 | 40 | 45 | 50 |

1. Time of Removal

The following requirements replace those of Article 3.4.8.2.

Do not remove forms until the concrete has attained strengths required in Article 420-16 of the Standard Specifications and these Special Provisions.

Do not remove forms until the concrete has sufficient strength to prevent damage to the surface.

ST-19

Project U-3109A

Alamance County

Table 2.2A - Steady State Maximum Wind Speeds by Counties in North Carolina

| COUNTY | 25 YR (mph) | COUNTY | 25 YR (mph) | COUNTY | 25 YR (mph) |
|------------|----------------|-------------|----------------|--------------|----------------|
| Alamance | 70 | Franklin | 70 | Pamlico | 100 |
| Alexander | 70 | Gaston | 70 | Pasquotank | 100 |
| Alleghany | 70 | Gates | 90 | Pender | 100 |
| Anson | 70 | Graham | 80 | Perquimans | 100 |
| Ashe | 70 | Granville | 70 | Person | 70 |
| Avery | 70 | Greene | 80 | Pitt | 90 |
| Beaufort | 100 | Guilford | 70 | Polk | 80 |
| Bertie | 90 | Halifax | 80 | Randolph | 70 |
| Bladen | 90 | Harnett | 70 | Richmond | 70 |
| Brunswick | 100 | Haywood | 80 | Robeson | 80 |
| Buncombe | 80 | Henderson | 80 | Rockingham | 70 |
| Burke | 70 | Hertford | 90 | Rowan | 70 |
| Cabarrus | 70 | Hoke | 70 | Rutherford | 70 |
| Caldwell | 70 | Hyde | 110 | Sampson | 90 |
| Camden | 100 | Iredell | 70 | Scotland | 70 |
| Carteret | 110 | Jackson | 80 | Stanley | 70 |
| Caswell | 70 | Johnston | 80 | Stokes | 70 |
| Catawba | 70 | Jones | 100 | Surry | 70 |
| Cherokee | 80 | Lee | 70 | Swain | 80 |
| Chatham | 70 | Lenoir | 90 | Transylvania | 80 |
| Chowan | 90 | Lincoln | 70 | Tyrell | 100 |
| Clay | 80 | Macon | 80 | Union | 70 |
| Cleveland | 70 | Madison | 80 | Vance | 70 |
| Columbus | 90 | Martin | 90 | Wake | 70 |
| Craven | 100 | McDowell | 70 | Warren | 70 |
| Cumberland | 80 | Mecklenburg | 70 | Washington | 100 |
| Currituck | 100 | Mitchell | 70 | Watauga | 70 |
| Dare | 110 | Montgomery | 70 | Wayne | 80 |
| Davidson | 70 | Moore | 70 | Wilkes | 70 |
| Davie | 70 | Nash | 80 | Wilson | 80 |
| Duplin | 90 | New Hanover | 100 | Yadkin | 70 |
| Durham | 70 | Northampton | 80 | Yancey | 70 |
| Edgecombe | 80 | Onslow | 100 | | |
| Forsyth | 70 | Orange | 70 | | |

B. Review and Approval

The Engineer is responsible for the review and approval of temporary works' drawings.

Submit the working drawings sufficiently in advance of proposed use to allow for their review, revision (if needed), and approval without delay to the work.

The time period for review of the working drawings does not begin until complete drawings and design calculations, when required, are received by the Engineer.

Do not start construction of any temporary work for which working drawings are required until the drawings have been approved. Such approval does not relieve the Contractor of the responsibility for the accuracy and adequacy of the working drawings.

CONSTRUCTION REQUIREMENTS

All requirements of Section 420 of the Standard Specifications apply.

Construct temporary works in conformance with the approved working drawings. Ensure that the quality of materials and workmanship employed is consistent with that assumed in the design of the temporary works. Do not weld falsework members to any portion of the permanent structure unless approved. Show any welding to the permanent structure on the approved construction drawings.

Provide tell-tales attached to the forms and extending to the ground, or other means, for accurate measurement of falsework settlement. Make sure that the anticipated compressive settlement and/or deflection of falsework does not exceed 1 inch. For cast-in-place concrete structures, make sure that the calculated deflection of falsework flexural members does not exceed 1/240 of their span regardless of whether or not the deflection is compensated by camber strips.

A. Maintenance and Inspection

Inspect and maintain the temporary work in an acceptable condition throughout the period of its use. Certify that the manufactured devices have been maintained in a condition to allow them to safely carry their rated loads. Clearly mark each piece so that its capacity can be readily determined at the job site.

Perform an in-depth inspection of an applicable portion(s) of the temporary works, in the presence of the Engineer, not more than 24 hours prior to the beginning of each concrete placement. Inspect other temporary works at least once a month to ensure that they are functioning properly. Have a North Carolina Registered Professional Engineer inspect the cofferdams, shoring, sheathing, support of excavation structures, and support systems for load tests prior to loading.

B. Foundations

Determine the safe bearing capacity of the foundation material on which the supports for temporary works rest. If required by the Engineer, conduct load tests to verify proposed bearing capacity values that are marginal or in other high-risk situations.

The use of the foundation support values shown on the contract plans of the permanent structure is permitted if the foundations are on the same level and on the same soil as those of the permanent structure.

Allow for adequate site drainage or soil protection to prevent soil saturation and washout of the soil supporting the temporary works supports.

If piles are used, the estimation of capacities and later confirmation during construction using standard procedures based on the driving characteristics of the pile is permitted. If preferred, use load tests to confirm the estimated capacities; or, if required by the Engineer conduct load tests to verify bearing capacity values that are marginal or in other high risk situations.

The Engineer reviews and approves the proposed pile and soil bearing capacities.

REMOVAL

Unless otherwise permitted, remove and keep all temporary works upon completion of the work. Do not disturb or otherwise damage the finished work.

Remove temporary works in conformance with the contract documents. Remove them in such a manner as to permit the structure to uniformly and gradually take the stresses due to its own weight.

METHOD OF MEASUREMENT

Unless otherwise specified, temporary works will not be directly measured.

BASIS OF PAYMENT

Payment at the contract unit prices for the various pay items requiring temporary works will be full compensation for the above falsework and formwork.

SUBMITTAL OF WORKING DRAWINGS

(6-19-15)

1.0 GENERAL

Submit working drawings in accordance with Article 105-2 of the *Standard Specifications* and this provision. For this provision, “submittals” refers to only those listed in this provision. The list of submittals contained herein does not represent a list of required submittals for the project. Submittals are only necessary for those items as required by the contract. Make submittals that are not specifically noted in this provision directly to the Engineer. Either the Structures Management Unit or the Geotechnical Engineering Unit or both units will jointly review submittals.

If a submittal contains variations from plan details or specifications or significantly affects project cost, field construction or operations, discuss the submittal with and submit all copies to the Engineer. State the reason for the proposed variation in the submittal. To minimize review time, make sure all submittals are complete when initially submitted. Provide a contact name and information with each submittal. Direct any questions regarding submittal requirements to the Engineer, Structures Management Unit contacts or the Geotechnical Engineering Unit contacts noted below.

In order to facilitate in-plant inspection by NCDOT and approval of working drawings, provide the name, address and telephone number of the facility where fabrication will actually be done if different than shown on the title block of the submitted working drawings. This includes, but is not limited to, precast concrete items, prestressed concrete items and fabricated steel or aluminum items.

ADDRESSES AND CONTACTS

For submittals to the Structures Management Unit, use the following addresses:

Via US mail:

Mr. T. K. Koch, P. E.
State Structures Engineer
North Carolina Department of
Transportation
Structures Management Unit
1581 Mail Service Center
Raleigh, NC 27699-1581

Via other delivery service:

Mr. T. K. Koch, P. E.
State Structures Engineer
North Carolina Department of
Transportation
Structures Management Unit
1000 Birch Ridge Drive
Raleigh, NC 27610

Attention: Mr. P. D. Lambert, P. E.

Attention: Mr. P. D. Lambert, P. E.

Submittals may also be made via email. Send submittals to:

plambert@ncdot.gov

(Paul Lambert)

ST-23

Project U-3109A

Alamance County

Send an additional e-copy of the submittal to the following addresses:

jgaither@ncdot.ov

(James Gaither)

mrorie@ncdot.gov

(Madonna Rorie)

For submittals to the Geotechnical Engineering Unit, use the following addresses:

For projects in Divisions 1-7, use the following Eastern Regional Office address:

Via US mail:

Mr. K. J. Kim, Ph. D., P. E.
Eastern Regional Geotechnical
Manager
North Carolina Department of
Transportation
Geotechnical Engineering Unit -
Eastern Regional Office
1570 Mail Service Center
Raleigh, NC 27699-1570

Via other delivery service:

Mr. K. J. Kim, Ph. D., P. E.
Eastern Regional Geotechnical
Manager
North Carolina Department of
Transportation
Geotechnical Engineering Unit -
Eastern Regional Office
3301 Jones Sausage Road, Suite 100
Garner, NC 27529

For projects in Divisions 8-14, use the following Western Regional Office address:

Via US mail:

Mr. Eric Williams, P. E.
Western Regional Geotechnical
Manager
North Carolina Department of
Transportation
Geotechnical Engineering Unit -
Western Regional Office
5253 Z Max Boulevard
Harrisburg, NC 28075

Via other delivery service:

Mr. Eric Williams, P. E.
Western Regional Geotechnical
Manager
North Carolina Department of
Transportation
Geotechnical Engineering Unit -
Western Regional Office
5253 Z Max Boulevard
Harrisburg, NC 28075

The status of the review of structure-related submittals sent to the Structures Management Unit can be viewed from the Unit's web site, via the "Drawing Submittal Status" link.

Direct any questions concerning submittal review status, review comments or drawing markups to the following contacts:

Primary Structures Contact:

Paul Lambert (919) 707-6407
(919) 250-4082 facsimile

Secondary Structures Contacts:

James Gaither (919) 707-6409
Madonna Rorie (919) 707-6508

Eastern Regional Geotechnical Contact (Divisions 1-7):

K. J. Kim (919) 662-4710

ST-24

Project U-3109A

Alamance County

(919) 662-3095 facsimile
kkim@ncdot.gov

Western Regional Geotechnical Contact (Divisions 8-14):

Eric Williams (704) 455-8902
(704) 455-8912 facsimile
ewilliams3@ncdot.gov

SUBMITTAL COPIES

Furnish one complete copy of each submittal, including all attachments, to the Engineer. At the same time, submit the number of hard copies shown below of the same complete submittal directly to the Structures Management Unit and/or the Geotechnical Engineering Unit.

The first table below covers “Structure Submittals”. The Engineer will receive review comments and drawing markups for these submittals from the Structures Management Unit. The second table in this section covers “Geotechnical Submittals”. The Engineer will receive review comments and drawing markups for these submittals from the Geotechnical Engineering Unit.

Unless otherwise required, submit one set of supporting calculations to either the Structures Management Unit or the Geotechnical Engineering Unit unless both units require submittal copies in which case submit a set of supporting calculations to each unit. Provide additional copies of any submittal as directed.

STRUCTURE SUBMITTALS

| Submittal | Copies Required by Structures Management Unit | Copies Required by Geotechnical Engineering Unit | Contract Reference Requiring Submittal ¹ |
|------------------------------------|--|---|--|
| Arch Culvert Falsework | 5 | 0 | Plan Note, SN Sheet & “Falsework and Formwork” |
| Box Culvert Falsework ⁷ | 5 | 0 | Plan Note, SN Sheet & “Falsework and Formwork” |
| Cofferdams | 6 | 2 | Article 410-4 |
| Foam Joint Seals ⁶ | 9 | 0 | “Foam Joint Seals” |

ST-25

Project U-3109A

Alamance County

STRUCTURE SUBMITTALS

| Submittal | Copies Required by Structures Management Unit | Copies Required by Geotechnical Engineering Unit | Contract Reference Requiring Submittal ¹ |
|---|--|---|--|
| Expansion Joint Seals (hold down plate type with base angle) | 9 | 0 | “Expansion Joint Seals” |
| Expansion Joint Seals (modular) | 2, then 9 | 0 | “Modular Expansion Joint Seals” |
| Expansion Joint Seals (strip seals) | 9 | 0 | “Strip Seals” |
| Falsework & Forms ² (substructure) | 8 | 0 | Article 420-3 & “Falsework and Formwork” |
| Falsework & Forms (superstructure) | 8 | 0 | Article 420-3 & “Falsework and Formwork” |
| Girder Erection over Railroad | 5 | 0 | Railroad Provisions |
| Maintenance and Protection of Traffic Beneath Proposed Structure | 8 | 0 | “Maintenance and Protection of Traffic Beneath Proposed Structure at Station ____” |
| Metal Bridge Railing | 8 | 0 | Plan Note |
| Metal Stay-in-Place Forms | 8 | 0 | Article 420-3 |
| Metalwork for Elastomeric Bearings ^{4,5} | 7 | 0 | Article 1072-8 |
| Miscellaneous Metalwork ^{4,5} | 7 | 0 | Article 1072-8 |
| Disc Bearings ⁴ | 8 | 0 | “Disc Bearings” |
| Overhead and Digital Message Signs (DMS) (metalwork and foundations) | 13 | 0 | Applicable Provisions |
| Placement of Equipment on Structures (cranes, etc.) | 7 | 0 | Article 420-20 |
| Precast Concrete Box Culverts | 2, then 1 reproducible | 0 | “Optional Precast Reinforced Concrete Box Culvert at Station ____” |

ST-26

Project U-3109A

Alamance County

STRUCTURE SUBMITTALS

| Submittal | Copies Required by Structures Management Unit | Copies Required by Geotechnical Engineering Unit | Contract Reference Requiring Submittal ¹ |
|--|--|---|--|
| Prestressed Concrete Cored Slab (detensioning sequences) ³ | 6 | 0 | Article 1078-11 |
| Prestressed Concrete Deck Panels | 6 and 1 reproducible | 0 | Article 420-3 |
| Prestressed Concrete Girder (strand elongation and detensioning sequences) | 6 | 0 | Articles 1078-8 and 1078-11 |
| Removal of Existing Structure over Railroad | 5 | 0 | Railroad Provisions |
| Revised Bridge Deck Plans (adaptation to prestressed deck panels) | 2, then 1 reproducible | 0 | Article 420-3 |
| Revised Bridge Deck Plans (adaptation to modular expansion joint seals) | 2, then 1 reproducible | 0 | “Modular Expansion Joint Seals” |
| Sound Barrier Wall (precast items) | 10 | 0 | Article 1077-2 & “Sound Barrier Wall” |
| Sound Barrier Wall Steel Fabrication Plans ⁵ | 7 | 0 | Article 1072-8 & “Sound Barrier Wall” |
| Structural Steel ⁴ | 2, then 7 | 0 | Article 1072-8 |
| Temporary Detour Structures | 10 | 2 | Article 400-3 & “Construction, Maintenance and Removal of Temporary Structure at Station ____” |
| TFE Expansion Bearings ⁴ | 8 | 0 | Article 1072-8 |

ST-27

Project U-3109A

Alamance County

FOOTNOTES

1. References are provided to help locate the part of the contract where the submittals are required. References in quotes refer to the provision by that name. Articles refer to the *Standard Specifications*.
2. Submittals for these items are necessary only when required by a note on plans.
3. Submittals for these items may not be required. A list of pre-approved sequences is available from the producer or the Materials & Tests Unit.
4. The fabricator may submit these items directly to the Structures Management Unit.
5. The two sets of preliminary submittals required by Article 1072-8 of the *Standard Specifications* are not required for these items.
6. Submittals for Fabrication Drawings are not required. Submittals for Catalogue Cuts of Proposed Material are required. See Section 5.A of the referenced provision.
7. Submittals are necessary only when the top slab thickness is 18" or greater.

GEOTECHNICAL SUBMITTALS

| Submittal | Copies Required by Geotechnical Engineering Unit | Copies Required by Structures Management Unit | Contract Reference Requiring Submittal ¹ |
|--|---|--|--|
| Drilled Pier Construction Plans ² | 1 | 0 | Subarticle 411-3(A) |
| Crosshole Sonic Logging (CSL) Reports ² | 1 | 0 | Subarticle 411-5(A)(2) |
| Pile Driving Equipment Data Forms ^{2,3} | 1 | 0 | Subarticle 450-3(D)(2) |
| Pile Driving Analyzer (PDA) Reports ² | 1 | 0 | Subarticle 450-3(F)(3) |
| Retaining Walls ⁴ | 8 drawings, 2 calculations | 2 drawings | Applicable Provisions |
| Temporary Shoring ⁴ | 5 drawings, 2 calculations | 2 drawings | “Temporary Shoring” & “Temporary Soil Nail Walls” |

FOOTNOTES

1. References are provided to help locate the part of the contract where the submittals are required. References in quotes refer to the provision by that name. Subarticles refer to the *Standard Specifications*.
2. Submit one hard copy of submittal to the Engineer. Submit a second copy of submittal electronically (PDF via email) or by facsimile, US mail or other delivery service to the appropriate Geotechnical Engineering Unit regional office. Electronic submission is preferred.
3. The Pile Driving Equipment Data Form is available from:
https://connect.ncdot.gov/resources/Geological/Pages/Geotech_Forms_Details.aspx
See second page of form for submittal instructions.
4. Electronic copy of submittal is required. See referenced provision.

CRANE SAFETY

(8-15-05)

Comply with the manufacturer specifications and limitations applicable to the operation of any and all cranes and derricks. Prime contractors, sub-contractors, and fully operated rental companies shall comply with the current Occupational Safety and Health Administration regulations (OSHA).

Submit all items listed below to the Engineer prior to beginning crane operations involving critical lifts. A critical lift is defined as any lift that exceeds 75 percent of the manufacturer's crane chart capacity for the radius at which the load will be lifted or requires the use of more than one crane. Changes in personnel or equipment must be reported to the Engineer and all applicable items listed below must be updated and submitted prior to continuing with crane operations.

CRANE SAFETY SUBMITTAL LIST

- A. **Competent Person:** Provide the name and qualifications of the "Competent Person" responsible for crane safety and lifting operations. The named competent person will have the responsibility and authority to stop any work activity due to safety concerns.
- B. **Riggers:** Provide the qualifications and experience of the persons responsible for rigging operations. Qualifications and experience should include, but not be limited to, weight calculations, center of gravity determinations, selection and inspection of sling and rigging equipment, and safe rigging practices.
- C. **Crane Inspections:** Inspection records for all cranes shall be current and readily accessible for review upon request.
- D. **Certifications:** **By July 1, 2006**, crane operators performing critical lifts shall be certified by NC CCO (National Commission for the Certification of Crane Operators), or satisfactorily complete the Carolinas AGC's Professional Crane Operator's Proficiency Program. Other approved nationally accredited programs will be considered

upon request. All crane operators shall also have a current CDL medical card. Submit a list of anticipated critical lifts and corresponding crane operator(s). Include current certification for the type of crane operated (small hydraulic, large hydraulic, small lattice, large lattice) and medical evaluations for each operator.

GROUT FOR STRUCTURES

(9-30-11)

1.0 DESCRIPTION

This special provision addresses grout for use in pile blockouts, grout pockets, shear keys, dowel holes and recesses for structures. This provision does not apply to grout placed in post-tensioning ducts for bridge beams, girders, or decks. Mix and place grout in accordance with the manufacturer's recommendations, the applicable sections of the Standard Specifications and this provision.

MATERIAL REQUIREMENTS

Use a Department approved pre-packaged, non-shrink, non-metallic grout. Contact the Materials and Tests Unit for a list of approved pre-packaged grouts and consult the manufacturer to determine if the pre-packaged grout selected is suitable for the required application.

When using an approved pre-packaged grout, a grout mix design submittal is not required.

The grout shall be free of soluble chlorides and contain less than one percent soluble sulfate. Supply water in compliance with Article 1024-4 of the Standard Specifications.

Aggregate may be added to the mix only where recommended or permitted by the manufacturer and Engineer. The quantity and gradation of the aggregate shall be in accordance with the manufacturer's recommendations.

Admixtures, if approved by the Department, shall be used in accordance with the manufacturer's recommendations. The manufacture date shall be clearly stamped on each container. Admixtures with an expired shelf life shall not be used.

The Engineer reserves the right to reject material based on unsatisfactory performance.

Initial setting time shall not be less than 10 minutes when tested in accordance with ASTM C266.

Test the expansion and shrinkage of the grout in accordance with ASTM C1090. The grout shall expand no more than 0.2% and shall exhibit no shrinkage. Furnish a Type 4 material certification showing results of tests conducted to determine the properties listed in the Standard Specifications and to assure the material is non-shrink.

Unless required elsewhere in the contract the compressive strength at 3 days shall be at least 5000 psi. Compressive strength in the laboratory shall be determined in accordance with

ST-30

Project U-3109A

Alamance County

ASTM C109 except the test mix shall contain only water and the dry manufactured material. Compressive strength in the field will be determined by molding and testing 4" x 8" cylinders in accordance with AASHTO T22. Construction loading and traffic loading shall not be allowed until the 3 day compressive strength is achieved.

When tested in accordance with ASTM C666, Procedure A, the durability factor of the grout shall not be less than 80.

SAMPLING AND PLACEMENT

Place and maintain components in final position until grout placement is complete and accepted. Concrete surfaces to receive grout shall be free of defective concrete, laitance, oil, grease and other foreign matter. Saturate concrete surfaces with clean water and remove excess water prior to placing grout.

Do not place grout if the grout temperature is less than 50°F or more than 90°F or if the air temperature measured at the location of the grouting operation in the shade away from artificial heat is below 45°F.

Provide grout at a rate that permits proper handling, placing and finishing in accordance with the manufacturer's recommendations unless directed otherwise by the Engineer. Use grout free of any lumps and undispersed cement. Agitate grout continuously before placement.

Control grout delivery so the interval between placing batches in the same component does not exceed 20 minutes.

The Engineer will determine the locations to sample grout and the number and type of samples collected for field and laboratory testing. The compressive strength of the grout will be considered the average compressive strength test results of 3 cube or 2 cylinder specimens at 28 days.

BASIS OF PAYMENT

No separate payment will be made for "Grout for Structures". The cost of the material, equipment, labor, placement, and any incidentals necessary to complete the work shall be considered incidental to the structure item requiring grout.

ST-31

Project U-3109A

Alamance County

EMBEDDED CLIPS FOR PRESTRESSED CONCRETE GIRDERS

(6-22-16)

The 2012 Standard Specifications shall be revised as follows:

Replace Section **420-3(D) – Forms for Concrete Bridge Decks**, Subsection **(2) – Fabricated Metal Stay-In-Place Forms**, criterion **(j)** with the following:

Weld metal stay-in-place forms for prestressed concrete girders to embedded clips in the girder flanges. The embedded clips shall be at least 2" x 3" and 2" long. The clips shall be galvanized, 10-gauge ASTM A653 steel and have a 3/4" or 1" diameter hole in the 2" leg. The spacing of the clips shall be 12". All submitted metal stay-in-place form designs shall be able to use the standard size and spacing of the clip described above.

2 BAR METAL RAIL RETROFIT

(SPECIAL)

Construct the 2 bar metal rail retrofit in accordance with the applicable sections of the Standard Specifications, the details shown on the plans and this special provision.

The quantity of 2 bar metal rail retrofit will be the actual number of linear feet of rail, measured in place from end post to end post, which has been completed and accepted. Construction of the end posts is included in the price of the 2 bar metal rail retrofit and will not be paid for separately. There will be no measurement made for installing adhesive anchors/dowels in the concrete barrier rail as such work is considered incidental.

Work includes but is not limited to construction of end posts, furnishing and installing 2 bar metal rail, posts, adhesive anchors, and any other materials necessary to complete the work as described in the plans and this special provision.

Payment will be made under:

2 Bar Metal Rail Retrofit _____ Linear Foot

SPECIAL PROVISIONS FOR PROTECTION OF RAILWAY INTEREST

Under the terms of these provisions, the North Carolina Department of Transportation shall hereinafter be called “Department”, the North Carolina Railroad Company shall hereinafter be called “Company” and the Norfolk Southern Railway Company shall hereinafter be called “Railroad”.

1. **AUTHORITY OF COMPANY ENGINEER, RAILROAD ENGINEER
AND DEPARTMENT ENGINEER:**

The Railroad and their authorized representative shall have final authority in all matters affecting the safe maintenance of railroad traffic including the adequacy of the foundations and structures supporting the railroad tracks. For Projects impacting the Railroad, the Railroad’s Engineer, hereinafter referred to as “Railroad Engineer”, will serve as the authorized representative of the Railroad.

The Company and their authorized representative shall have final authority in all matters for Projects impacting the Company’s property, which lie entirely beyond 25 feet from the tracks and do not impact the railroad tracks. The Company’s Engineer, hereinafter referred to as “Company Engineer”, will serve as the authorized representative of the Company.

The authorized representative of the North Carolina Department of Transportation hereinafter referred to as the “Department Engineer”, shall have authority over all other matters as prescribed herein and in the Project Specifications, Special Provisions, and the plans.

The Department’s Prime Contractor, hereinafter referred to as “Contractor” shall be responsible for completing any and all work in accordance with the terms prescribed herein and in the Project Specifications.

2. **NOTICE OF STARTING WORK:**

A. The Contractor shall not commence any work on the Company’s corridor until he has complied with the following conditions:

1. Signed and received a fully executed copy of the required North Carolina Railroad Company Right of Entry Agreement.
2. Given the Railroad written notice in electronic format to the Railroad Engineer, with a copy to the Company Engineer, and with copy to the Department Engineer, at least ten days in advance of the date he proposes to begin work on Company’s corridor.
3. Obtained written approval from the Company and Railroad of Railroad Protective Liability Insurance coverage as required by paragraph 14 herein. It should be noted that the Railroad and Company does not accept notation of Railroad Protective insurance on a certificate of liability insurance form or Binders as Railroad and Company must have the full original countersigned policy. Further, please note that mere receipt of the policy is not the only issue but review for compliance. Due to the number of projects system-wide, it typically takes a minimum of 30-45 days for the Railroad to review.

4. Obtained Railroad's Flagging Services as required by paragraph 7 herein.
 5. Obtained written authorization from the Railroad to begin work on Company's corridor, such authorization to include an outline of specific conditions with which the Contractor must comply. Contractor is responsible for completing the "Norfolk Southern Checklist for Construction" located at the end of these provisions.
 6. Furnished a schedule for all work within the Company's corridor as required by paragraph 7.B.1. to the Company and Railroad.
- B. The Railroad's written authorization to proceed with the work shall include the names, addresses, and telephone numbers of the Railroad's representatives who are to be notified as hereinafter required. Where more than one representative is designated, the area of responsibility of each representative will be specified.
3. INTERFERENCE WITH RAILROAD OPERATIONS:
- A. The Contractor shall so arrange and conduct his work that there will be no interference with Railroad's operations, including train, signal, telephone and telegraphic services, or damage to the property of the Company or Railroad or to poles, wires, and other facilities of tenants on the Company's corridor. Whenever work is liable to affect the operations or safety of trains, the method of doing such work shall first be submitted to the Railroad Engineer for approval, but such approval shall not relieve the Contractor from liability. Any work to be performed by the Contractor which requires flagging service or inspection service shall be deferred by the Contractor until the flagging service or inspection service required by the Railroad is available at the job site.
 - B. Whenever work within Company's corridor is of such a nature that impediment to Railroad's operations such as use of runaround tracks or necessity for reduced speed is unavoidable, the Contractor shall schedule and conduct his operations so that such impediment is reduced to the absolute minimum.
 - C. Should conditions arising from, or in connection with the work, require that immediate and unusual provisions be made to protect operations and property of the Railroad and Company, the Contractor shall make such provisions. If in the judgment of the Railroad Engineer, or in his absence, the Railroad's Division Engineer, such provisions are insufficient, either may require or provide such provisions as he deems necessary. In any event, such unusual provisions shall be at the Contractor's expense and without cost to the Company, the Railroad or the Department.
 - D. "One Call" Services do not locate buried Railroad utilities. The contractor shall contact the Railroad's representative 2 days in advance of work at those places where excavation, pile driving, or heavy loads may damage the Railroad's underground facilities. Upon request from the Contractor or Department, Railroad forces will locate and paint mark or flag the Railroad's underground facilities. The Contractor shall avoid excavation or other disturbances of these facilities. If disturbance or excavation is required near a buried Railroad facility, the contractor shall coordinate with the Railroad to have the facility potholed manually with careful hand excavation.

The facility shall be protected by the Contractor during the course of the disturbance under the supervision and direction of the Railroad's representative.

4. TRACK CLEARANCES:

A. The minimum track clearances to be maintained by the Contractor during construction are shown on the Project Plans. If temporary clearances are not shown on the project plans, the following criteria shall govern the use of falsework and formwork above or adjacent to operated tracks.

1. A minimum vertical clearance of 22'-0" above top of highest rail shall be maintained at all times.
2. A minimum horizontal clearance of 13'-0" from centerline of tangent track or 14'-0" from centerline of curved track shall be maintained at all times. Additional horizontal clearance may be required in special cases to be safe for operating conditions. This additional clearance will be as determined by the Railroad Engineer.
3. All proposed temporary clearances which are less than those listed above must be submitted to Railroad Engineer for approval prior to construction.
4. The temporary clearance requirements noted above shall also apply to all other physical obstructions including, but not limited to: stockpiled materials, parked equipment, placement or driving of piles, and bracing or other construction supports.

B. Before undertaking any work within Company corridor, and before placing any obstruction over any track, the Contractor shall:

1. Notify the Railroad's representative at least 72 hours in advance of the work.
2. Receive assurance from the Railroad's representative that arrangements have been made for flagging service as may be necessary.
3. Receive permission from the Railroad's representative to proceed with the work.
4. Ascertain that the Company Engineer and the Department's Engineer have received copies of notice to the Railroad and of the Railroad's response thereto.

5. CONSTRUCTION PROCEDURES:

A. General:

1. Construction work and operations by the Contractor on Company's corridor and property shall be:
 - a. Subject to the inspection and approval of the Railroad Engineer or their designated Construction Engineering Representative.
 - b. In accordance with the Railroad's written outline of specific conditions.
 - c. In accordance with the hose relating to safety, fall protection and personal protective equipment.
 - d. In accordance with these Special Provisions.

2. Submittal Requirements

- a. The Contractor shall submit all construction related correspondence and submittals electronically to the Railroad Engineer and the Company Engineer.
- b. The Contractor shall allow a minimum of 30 days for the Railroad's, and Company's if required, review and response.
- c. All work in the vicinity of the Company's or Railroad's corridor and property that has the potential to affect the Railroad's train operations or disturb the Company's or Railroad's Property must be submitted and approved by the Railroad, and Company if required, prior to work being performed.
- d. All submittals and calculations must be signed and sealed by a registered engineer licensed in the State of North Carolina.
- e. All submittals shall first be approved by the Department's Engineer and the Railroad Engineer, but such approval shall not relieve the Contractor from liability.
- f. For all construction projects, the following submittals, but not limited to those listed below, shall be provided for review and approval when applicable:
 - (1) General Means and Methods
 - (2) Ballast Protection
 - (3) Construction Excavation & Shoring
 - (4) Pipe, Culvert, & Tunnel Installations
 - (5) Demolition Procedure
 - (6) Erection & Hoisting Procedure
 - (7) Debris Shielding or Containment
 - (8) Blasting
 - (9) Formwork for the bridge deck, diaphragms, overhang brackets, and protective platforms
 - (10) Bent Cap Falsework. A lift plan will be required if the contractor want to move the falsework over the tracks.
- g. For Undergrade Bridges (Bridges carrying the Railroad) the following submittals in addition to those listed above shall be provided for review and approval:
 - (1) Shop Drawings
 - (2) Bearing Shop Drawings and Material Certifications
 - (3) Concrete Mix Design
 - (4) Structural Steel, Rebar, and/or Strand Certifications
 - (5) 28 day Cylinder Test for Concrete Strength
 - (6) Waterproofing Material Certification
 - (7) Test Reports for Fracture Critical Members

(8) Foundation Construction Reports

Fabrication may not begin until the Railroad has approved the required shop drawings.

- h. The Contractor shall include in all submissions a detailed narrative indicating the progression of work with the anticipated timeframe to complete each task. Work will not be permitted to commence until the Contractor has provided the Railroad with a satisfactory plan that the project will be undertaken without scheduling, performance or safety related issues. Submission shall also provide a listing of the anticipated equipment to be used, the location of all equipment to be used and insure a contingency plan of action is in place should a primary piece of equipment malfunction.

B. Ballast Protection

1. The Contractor shall submit the proposed ballast protection system detailing the specific filter fabric and anchorage system to be used during all construction activities.
2. The ballast protection is to extend 25' beyond the proposed limit of work, be installed at the start of the project and be continuously maintained to prevent all contaminants from entering the ballast section of all tracks for the entire duration of the project.

C. Excavation:

1. The subgrade of an operated track shall be maintained with edge of berm at least 10'-0" from centerline of track and not more than 24-inches below top of rail. Contractor will not be required to make existing section meet this specification if substandard, in which case existing section will be maintained.
2. Additionally, the Railroad will require the installation of an OSHA approved handrail and orange construction safety fencing for all excavations of the Company's corridor.

D. Excavation for Structures and Shoring Protection:

1. The Contractor will be required to take special precaution and care in connection with excavating and shoring pits, and in driving piles or sheeting for footings adjacent to tracks to provide adequate lateral support for the tracks and the loads which they carry, without disturbance of track alignment and surface, and to avoid obstructing track clearances with working equipment, tools or other material. The Contractor will be required to follow the following guidelines for shoring design if a Railroad approved shoring system is not included in the contract plans or an alternate system is proposed.
2. All plans and calculations for shoring shall be prepared, signed, and sealed by a Registered Professional Engineer licensed in the State of North Carolina, in accordance with Norfolk Southern's Overhead Grade Separation Design Criteria, subsection H.1.6.E-Construction Excavation (Refer to Norfolk Southern Public Projects Manual Appendix H). The Registered Professional Engineer will be

responsible for the accuracy for all controlling dimensions as well as the selection of soil design values which will accurately reflect the actual field conditions.

3. The Contractor shall provide a detailed installation and removal plan of the shoring components. Any component that will be installed via the use of a crane or any other lifting device shall be subject to the guidelines outlined in section 5.G of these provisions.
4. The Contractor shall be required to survey the track(s) and railroad embankment and provide a cross section of the proposed excavation in relation to the tracks.
5. Calculations for the proposed shoring should include deflection calculations. The maximum deflection for excavations within 18'-0" of the centerline of the nearest track shall be 3/8". For all other cases, the max deflection shall not exceed 1/2".
6. Additionally, the Railroad will require the installation of an OSHA approved handrail and orange construction safety fencing for all excavations of the Company's corridor.
7. The front face of shoring located to the closest NS track for all shoring set-ups located in Zone 2 as shown on NS Typical Drawing No. 4 – Shoring Requirements (Refer to Norfolk Southern Public Projects Manual Appendix I) shall remain in place and be cut off 2'-0" below the final ground elevation. The remaining shoring in Zone 2 and all shoring in Zone 1 may be removed and all voids must be backfilled with flowable fill.

E. Pipe, Culvert, & Tunnel Installations

1. Pipe, Culvert, & Tunnel Installations shall be in accordance with the appropriate Norfolk Southern Design Specification as noted below:
 - a. For Open Cut Method refer to Norfolk Southern Public Projects Manual Appendix H.4.6.
 - b. For Jack and Bore Method refer to Norfolk Southern Public Projects Manual Appendix H.4.7.
 - c. For Tunneling Method refer to Norfolk Southern Public Projects Manual Appendix H.4.8.
2. All closed pipeline systems shall be installed in accordance North Carolina Railroad Company's Form NCR 102 - Specifications for Pipeline Occupancy of North Carolina Railroad Property.

F. Wire Line Installations

1. All wireline systems shall be installed in accordance North Carolina Railroad Company's Form NCR 101 - Specifications for Wire, Conduit and Cable Occupations of North Carolina Railroad Property.

G. Demolition Procedures

1. General
 - a. Demolition plans are required for all spans over the track(s), for all spans adjacent to the track(s), if located on (or partially on) the Company's corridor; and in all situations where cranes will be situated on, over, or adjacent to the

Company's corridor and within a distance of the boom length plus 15'-0" from the centerline of track.

- b. Railroad tracks and other Company and Railroad property must be protected from damage during the procedure.
- c. A pre-demolition meeting shall be conducted with the Department, the Railroad Engineer or their representative, and the key Contractor's personnel prior to the start of the demolition procedure.
- d. The Railroad Engineer or his designated representative must be present at the site during the entire demolition procedure period.
- e. Existing, obsolete, bridge piers shall be removed to a sufficient depth below grade to enable restoration of the existing/proposed track ditch, but in no case less than 2'-0" below final grade.

2. Submittal Requirements

- a. In addition to the submittal requirements outlined in Section 5.A.2 of these provisions, the Contractor shall submit the following for approval by the Railroad Engineer:
 - (1) A plan showing the location of cranes, horizontally and vertically, operating radii, with delivery or disposal locations shown. The location of all tracks and other Company and Railroad facilities as well as all obstructions such as wire lines, poles, adjacent structures, etc. must also be shown.
 - (2) Rating sheets showing cranes or lifting devices to be adequate for 150% of the actual weight of the pick, including all rigging components. A complete set of crane charts, including crane, counterweight, and boom nomenclature is to be submitted. Safety factors that may have been "built-in" to the crane charts are not to be considered when determining the 150% factor of safety.
 - (3) Plans and computations showing the weight of the pick must be submitted. Calculations shall be made from plans of the existing structure showing complete and sufficient details with supporting data for the demolition the structure. If plans do not exist, lifting weights must be calculated from field measurements. The field measurements are to be made under the supervision of the Registered Professional Engineer submitting the procedure and calculations.
 - (4) The Contractor shall provide a sketch of all rigging components from the crane's hook block to the beam. Catalog cuts or information sheets of all rigging components with their lifting capacities shall be provided. All rigging must be adequate for 150% of the actual weight of the pick. Safety factors that may have been "built-in" to the rating charts are not to be considered when determining the 150% factor of safety. All rigging components shall be clearly identified and tagged with their rated lifting capacities. The position of the rigging in the field shall not differ from what is shown on the final plan without prior review from the Department and the Railroad.

- (5) A complete demolition procedure, including the order of lifts, time required for each lift, and any repositioning or re-hitching of the crane or cranes.
 - (6) Design and supporting calculations for the temporary support of components, including but not limited to the stability of the superstructure during the temporary condition, temporary girder tie-downs and falsework.
3. Overhead Demolition Debris Shield
- a. The demolition debris shield shall be installed prior to the demolition of the bridge deck or other relevant portions of the superstructure over the track area to catch all falling debris.
 - b. The demolition debris shield shall provide a minimum vertical clearance as specified in Section 4.A.1 of these provisions or maintain the existing vertical clearance if the existing clearance is less than that specified in Section 4.A.1.
 - c. The Contractor shall include the demolition debris shield installation/removal means and methods as part of the proposed Demolition procedure submission.
 - d. The Contractor shall submit the demolition debris shield design and supporting calculations for approval by the Railroad Engineer.
 - e. The demolition debris shield shall have a minimum design load of 50 pounds per square foot plus the weight of the equipment, debris, personnel, and other loads to be carried.
 - f. The Contractor shall include the proposed bridge deck removal procedure in its demolition means and methods and shall verify that the size and quantity of the demolition debris generated by the procedure does not exceed the shield design loads.
 - g. The Contractor shall clean the demolition debris shield daily or more frequently as dictated either by the approved design parameters or as directed by the Railroad Engineer.
4. Vertical Demolition Debris Shield
- a. A vertical demolition debris shield may be required for substructure removals in close proximity to the Company's track and other facilities, as determined by the Railroad Engineer.

H. Erection & Hoisting Procedures

1. General

- a. Erection plans are required for all spans over the track(s), for all spans adjacent to the track(s), if located on (or partially on) the Company's corridor; and in all situations where cranes will be situated on, over, or adjacent to the Company's corridor and within a distance of the boom length plus 15'-0" from the centerline of track.
- b. Railroad tracks and other Company and Railroad property must be protected from damage during the erection procedure.

- c. A pre-erection meeting shall be conducted with the Department, the Railroad Engineer or their representative, and the key Contractor's personnel prior to the start of the erection procedure.
- d. The Railroad Engineer or his designated representative must be present at the site during the entire erection procedure period.
- e. For field splices located over Company property, a minimum of 50% of the holes for each connection shall be filled with bolts or pins prior to releasing the crane. A minimum of 50% of the holes filled shall be filled with bolts. All bolts must be appropriately tightened. Any changes to previously approved field splice locations must be submitted to the Railroad for review and approval. Refer to Norfolk Southern's Overhead Grade Separation Design Criteria for additional splice details (Norfolk Southern Public Projects Manual Appendix H.1, Section 4.A.3.).

2. Submittal Requirements

- a. In addition the submittal requirements outlined in Section 5.A.2 of these provisions, the Contractor shall submit the following for approval by the Railroad Engineer:
 - (1) As-built beam seat elevations - All as-built bridge seats and top of rail elevations shall be furnished to the Railroad Engineer for review and verification at least 30 days in advance of the erection, to ensure that minimum vertical clearances as approved in the plans will be achieved.
 - (2) A plan showing the location of cranes, horizontally and vertically, operating radii, with delivery or staging locations shown. The location of all tracks and other Railroad and Company facilities as well as all obstructions such as wire lines, poles, adjacent structures, etc. must also be shown.
 - (3) Rating sheets showing cranes or lifting devices to be adequate for 150% of the actual weight of the pick, including all rigging components. A complete set of crane charts, including crane, counterweight, and boom nomenclature is to be submitted. Safety factors that may have been "built-in" to the crane charts are not to be considered when determining the 150% factor of safety.
 - (4) Plans and computations showing the weight of the pick must be submitted. Calculations shall be made from plans of the proposed structure showing complete and sufficient details with supporting data for the erection of the structure. If plans do not exist, lifting weights must be calculated from field measurements. The field measurements are to be made under the supervision of a North Carolina Registered Professional Engineer submitting the procedure and calculations.
 - (5) The Contractor shall provide a sketch of all rigging components from the crane's hook block to the beam. Catalog cuts or information sheets of all rigging components with their lifting capacities shall be provided. All rigging must be adequate for 150% of the actual weight of the pick. Safety factors that may have been "built-in" to the rating charts are not to be

considered when determining the 150% factor of safety. All rigging components shall be clearly identified and tagged with their rated lifting capacities. The position of the rigging in the field shall not differ from what is shown on the final plan without prior review from the Department and the Railroad.

- (6) A complete erection procedure, including the order of lifts, time required for each lift, and any repositioning or re-hitching of the crane or cranes.
- (7) Design and supporting calculations for the temporary support of components, including but not limited to temporary girder tie-downs and falsework.

I. Blasting:

1. The Contractor shall obtain advance approval of the Railroad Engineer and the Department Engineer for use of explosives on or adjacent to Company or Railroad property. The request for permission to use explosives shall include a detailed blasting plan. If permission for use of explosives is granted, the Contractor will be required to comply with the following:
 - a. Blasting shall be done with light charges under the direct supervision of a responsible officer or employee of the Contractor and a licensed blaster.
 - b. Electric detonating fuses shall not be used because of the possibility of premature explosions resulting from operation of two-way radios.
 - c. No blasting shall be done without the presence of the Railroad Engineer or his authorized representative. At least 72 hours advance notice to the person designated in the Railroad's notice of authorization to proceed (see paragraph 2.B) will be required to arrange for the presence of an authorized Railroad representative and such flagging as the Railroad may require.
 - d. Have at the job site adequate equipment, labor and materials and allow sufficient time to clean up debris resulting from the blasting without delay to trains, as well as correcting at his expense any track misalignment or other damage to Railroad property resulting from the blasting as directed by the Railway's authorized representative. If his actions result in delay of trains, the Contractor shall bear the entire cost thereof.
 - e. The blasting Contractor shall have a copy of the approved blasting plan on hand while on the site.
 - f. Explosive materials or loaded holes shall not be left unattended at the blast site.
 - g. A seismograph shall be placed on the track shoulder adjacent to each blast which will govern the peak particle velocity of two inches per second. Measurement shall also be taken on the ground adjacent to structures as designated by a qualified and independent blasting consultant. The Railroad reserves the option to direct the placement of additional seismographs at structures or other locations of concern, without regard to scaled distance.
 - h. After each blast, the blasting Contractor shall provide a copy of their drill log and blast report, which includes number of holes, depth of holes, and number of decks, type and pounds of explosives used per deck.

- i. The Railroad may require top of rail elevations and track centers taken before, during and after the blasting and excavation operation to check for any track misalignment resulting from the Contractor's activities.
2. The Railroad representative will:
 - a. Determine approximate location of trains and advise the Contractor the appropriate amount of time available for the blasting operation and clean up.
 - b. Have the authority to order discontinuance of blasting if, in his opinion, blasting is too hazardous or is not in accord with these special provisions.
3. The Contractor must hire, at no expense to the Railroad or the Company, a qualified and independent blasting consultant to oversee the use of explosives. The blasting consultant will:
 - a. Review the Contractor's proposed drilling and loading patterns, and with the blasting consultant's personnel and instruments, monitor the blasting operations.
 - b. Confirm that the minimum amounts of explosives are used to remove the rock.
 - c. Be empowered to intercede if he concludes that the Contractor's blasting operations are endangering the Railroad.
 - d. Submit a letter acknowledging that he has been engaged to oversee the entire blasting operation and that he approves of the blasting plan.
 - e. Furnish copies of all vibration readings to the Railroad representative immediately after each blast. The representative will sign and date the seismograph tapes after each shot to verify the readings are for that specific shot.
 - f. Advise the Railroad representative as to the safety of the operation and notify him of any modifications to the blasting operation as the work progresses.
4. The request for permission to use explosives on the Company's corridor shall include a blasting proposal providing the following details:
 - a. A drawing which shows the proposed blasting area, location of nearest hole and distance to Railway structures, all with reference to the centerline of track.
 - b. Hole diameter.
 - c. Hole spacing and pattern.
 - d. Maximum depth of hole.
 - e. Maximum number of decks per hole.
 - f. Maximum pounds of explosives per hole.
 - g. Maximum pounds of explosives per delay.
 - h. Maximum number of holes per detonation.
 - i. Type of detonator and explosives to be used. (Electronic detonating devices will not be permitted). Diameter of explosives if different from hole diameter.

- j. Approximate dates and time of day when the explosives are to be detonated.
- k. Type of flyrock protection.
- l. Type and patterns of audible warning and all clear signals to be used before and after each blast.
- m. A copy of the blasting license and qualifications of the person directly in charge of the blasting operation, including their name, address and telephone number.
- n. A copy of the Department's permit granting permission to blast on the site.
- o. A letter from the blasting consultant acknowledging that he has been engaged to oversee the entire blasting operation and that he approves of the blasting plan.
- p. In addition to the insurance requirements outlined in Paragraph 14 of these Provisions, A certificate of insurance from the Contractor's insurer stating the amount of coverage for XCU (Explosive Collapse and Underground Hazard) insurance and that XCU Insurance is in force for this project.
- q. A copy of the borings and Geotechnical information or report.

J. Track Monitoring

- 1. At the direction of the Railroad Engineer, any activity that has the potential to disturb the Railroad track structure may require the Contractor to submit a detailed track monitoring program for approval by the Railroad Engineer.
- 2. The program shall specify the survey locations, the distance between the location points, and frequency of monitoring before, during, and after construction. Railroad reserves the right to modify the survey locations and monitoring frequency as necessary during the project.
- 3. The survey data shall be collected in accordance with the approved frequency and immediately furnished to the Railroad Engineer for analysis.
- 4. If any movement has occurred as determined by the Railroad Engineer, the Railroad will be immediately notified. Railroad, at its sole discretion, shall have the right to immediately require all Contractor operations to be ceased and determine what corrective action is required. Any corrective action required by the Railroad or performed by the Railroad including the monitoring of corrective action of the Contractor will be at project expense

K. Maintenance of Railroad and Company Facilities:

- 1. The Contractor will be required to maintain all ditches and drainage structures free of silt or other obstructions which may result from his operations and provide and maintain any erosion control measures as required. The Contractor will promptly repair eroded areas within the Company's corridor and repair any other damage to the property of the Railroad, Company or its tenants.
- 2. If, in the course of construction, it may be necessary to block a ditch, pipe or other drainage facility, temporary pipes, ditches or other drainage facilities shall be installed to maintain adequate drainage, as approved by the Railroad Engineer.

Upon completion of the work, the temporary facilities shall be removed and the permanent facilities restored.

3. All such maintenance and repair of damages due to the Contractor's operations shall be done at the Contractor's expense.

L. Storage of Materials and Equipment:

1. Materials and equipment shall not be stored where they will interfere with Railroad operations, nor on the Company's corridor or property without first having obtained permission from the Company Engineer and Railroad Engineer, and such permission will be with the understanding that the Company and Railroad will not be liable for damage to such material and equipment from any cause and that the Company Engineer or Railroad Engineer may move or require the Contractor to move, at the Contractor's expense, such material and equipment.
2. All grading or construction machinery that is left parked near the track unattended by a watchman shall be effectively immobilized so that it cannot be moved by unauthorized persons. The Contractor shall protect, defend, indemnify and save Company and Railroad, and any associated, controlled or affiliated corporation, harmless from and against all losses, costs, expenses, claim or liability for loss or damage to property or the loss of life or personal injury, arising out of or incident to the Contractor's failure to immobilize grading or construction machinery.

M. Cleanup:

1. Upon completion of the work, the Contractor shall remove from within the limits of the Company's corridor and property, all machinery, equipment, surplus materials, falsework, rubbish or temporary buildings of the Contractor, and leave said corridor and property in a neat condition satisfactory to the Company Engineer and Railroad Engineer or their authorized representatives.

6. DAMAGES:

- A. The Contractor shall assume all liability for any and all damages to his work, employees, servants, equipment and materials caused by Railroad traffic.
- B. Any cost incurred by the Company or Railroad for repairing damages to its property or to property of its tenants, caused by or resulting from the operations of the Contractor, shall be paid directly to the Company or Railroad by the Contractor.

7. FLAGGING SERVICES:

A. Requirements:

1. Flagging services will not be provided until the Contractor's insurance has been reviewed & approved by the Company and Railroad.
2. Under the terms of the agreement between the Department, the Company and the Railroad, the Railroad has sole authority to determine the need for flagging required to protect its operations. In general, the requirements of such services will be whenever the Contractor's personnel or equipment are or are likely to be, working on the Company's corridor, or across, over, adjacent to, or under a track, or when such work has disturbed or is likely to disturb a

Railroad structure or the Railroad roadbed or surface and alignment of any track to such extent that the movement of trains must be controlled by flagging.

3. Normally, the Railroad will assign one flagman to a project; but in some cases, more than one may be necessary, such as yard limits where three (3) flagmen may be required. However, if the Contractor works within distances that violate instructions given by the Railroad's authorized representative or performs work that has not been scheduled with the Railroad's authorized representative, a flagman or flagmen may be required full time until the project has been completed. Should such violations or unscheduled, unauthorized work by the Contractor result in full time flagging being required by the Railroad, the additional cost of such flagging above normal flagging cost shall be deducted from the final payment by the Department to the Contractor as provided in Article 109-9 of the Standard Specifications. Neither Department nor Company nor Railroad will be liable for damages resulting from unscheduled or unauthorized work.
4. For Projects exceeding 30 days of construction, Contractor shall provide the flagmen a small work area with a desk/counter and chair within the field/site trailer, including the use of bathroom facilities, where the flagman can check in/out with the Project, as well as to the flagman's home terminal. The work area should provide access to two (2) electrical outlets for recharging radio(s), and a laptop computer; and have the ability to print off needed documentation and orders as needed at the field/site trailer. This should aid in maximizing the flagman's time and efficiency on the Project.

B. Scheduling and Notification:

1. The Contractor's work requiring Railroad flagging should be scheduled to limit the presence of a flagman at the site to a maximum of 50 hours per week. The Contractor shall receive Railroad approval of work schedules requiring a flagman's presence in excess of 40 hours per week.
2. Not later than the time that approval is initially requested to begin work on Company's corridor, Contractor shall furnish to the Railroad, the Company and the Department a schedule for all work required to complete the portion of the project within the Company's corridor and arrange for a job site meeting between the Contractor, the Department, and the Railroad's authorized representative. Flagman or Flagmen may not be provided until the job site meeting has been conducted and the Contractor's work scheduled.
3. The Contractor will be required to give the Railroad representative at least 10 working days of advance written notice of intent to begin work within the Company's corridor in accordance with this special provision. Once begun, when such work is then suspended at any time, or for any reason, the Contractor will be required to give the Railroad representative at least 3 working days of advance notice before resuming work on Company corridor. Such notices shall include sufficient details of the proposed work to enable the Railroad representative to determine if flagging will be required. If such notice is in writing, the Contractor shall furnish the Engineer a copy; if notice is given verbally, it shall be confirmed in writing with copy to the Engineer. If flagging is required, no work shall be

undertaken until the flagman, or flagmen are present at the job site. It may take up to 30 days to obtain flagging initially from the Railroad. When flagging begins, the flagman is usually assigned by the Railroad to work at the project site on a continual basis until no longer needed and cannot be called for on a spot basis. If flagging becomes unnecessary and is suspended, it may take up to 30 days to again obtain from the Railroad. Due to Railroad labor agreements, it is necessary to give 5 working days notice before flagging service may be discontinued and responsibility for payment stopped.

4. If, after the flagman is assigned to the project site, an emergency arises that requires the flagman's presence elsewhere, then the Contractor shall delay work on Company corridor until such time as the flagman is again available. Any additional costs resulting from such delay shall be borne by the Contractor and not the Department, the Company or the Railroad.

C. Payment:

1. The Department will be responsible for paying the Railroad directly for any and all costs of flagging which may be required to accomplish the construction. The Contractor shall reimburse the Railroad for any costs of the flagging which is required for the benefit of the Contractor.
2. The estimated cost of flagging is the current rate per day based on a 10-hour work day. This cost includes the base pay for the flagman, overhead, and includes a per diem charge for travel expenses, meals and lodging. The charge to the Department by the Railroad will be the actual cost based on the rate of pay for the Railroad's employees who are available for flagging service at the time the service is required.
3. Work by a flagman in excess of 8 hours per day or 40 hours per week, but not more than 12 hours a day will result in overtime pay at 1 and 1/2 times the appropriate rate. Work by a flagman in excess of 12 hours per day will result in overtime at 2 times the appropriate rate. If work is performed on a holiday, the flagging rate is 2 and 1/2 times the normal rate.
4. Railroad work involved in preparing and handling bills will also be charged to the Department. Charges to the Department by the Railroad shall be in accordance with applicable provisions of Subchapter B, Part 140, Subpart I and Subchapter G, Part 646, Subpart B of the Federal-Aid Policy Guide issued by the Federal Highway Administration on December 9, 1991, including all current amendments. Flagging costs are subject to change. The above estimates of flagging costs are provided for information only and are not binding in any way.

D. Verification:

1. Railroad's flagman will electronically enter flagging time via Railroad's electronic billing system. Any complaints concerning flagging must be resolved in a timely manner. If the need for flagging is questioned, please contact the Railroad Engineer. All verbal complaints will be confirmed in writing by the Contractor within 5 working days with a copy to the Department Engineer. Address all written correspondence electronically to Railroad Engineer.

2. The Railroad flagman assigned to the project will be responsible for notifying the Department Engineer upon arrival at the job site on the first day (or as soon thereafter as possible) that flagging services begin and on the last day that he performs such services for each separate period that services are provided. The Department's Engineer will document such notification in the project records. When requested, the Department Engineer will also sign the flagman's diary showing daily time spent and activity at the project site. Also if requested, the flagman will cooperate with the Department by submitting daily timesheets or signing the Department Engineer's diary showing daily time spent at the project site.
8. **HAUL ACROSS RAILROAD TRACK:**
 - A. Where the plans show or imply that materials of any nature must be hauled across tracks of the Company or Railroad, unless the plans clearly show that the Department has included arrangements for such haul in its agreement with the Railroad, the Contractor will be required to make all necessary arrangements with the Railroad regarding means of transporting such materials across the tracks of the Company or Railroad. The Contractor or Department will be required to bear all costs incidental to such crossings whether services are performed by his own forces or by Railroad personnel.
 - B. No crossing may be established for use of the Contractor for transporting materials or equipment across the tracks of the Company or Railroad unless specific authority for its installation, maintenance, necessary watching and flagging thereof and removal, until a temporary private crossing agreement has been executed between the Contractor and Railroad. The approval process for an agreement normally takes 90 days.
9. **WORK FOR THE BENEFIT OF THE CONTRACTOR:**
 - A. All temporary or permanent changes in wire lines or other facilities owned by the Company or Railroad and which are considered necessary to the project are shown on the plans; included in the force account agreement between the Department and the Railroad or will be covered by appropriate revisions to same which will be initiated and approved by the Department and/or the Railroad.
 - B. Should the Contractor desire any changes in addition to the above, then he shall make separate arrangements with the Railroad for same to be accomplished at the Contractor's expense.
10. **COOPERATION AND DELAYS:**
 - A. It shall be the Contractor's responsibility to arrange a schedule with the Railroad for accomplishing stage construction involving work by the Railroad or tenants of the Company. In arranging his schedule he shall ascertain, from the Railroad, the lead time required for assembling crews and materials and shall make due allowance therefore.
 - B. No charge or claim of the Contractor against either the Department, the Company or the Railroad will be allowed for hindrance or delay on account of railroad traffic; any work done by the Railroad or other delay incident to or necessary

for safe maintenance of railroad traffic or for any delays due to compliance with these special provisions.

- C. The Contractor's attention is called to the fact that neither the Department, Company nor Railroad assumes any responsibility for any work performed by others in connection with the construction of the project, and the Contractor shall have no claim whatsoever against the Department, Company or Railroad for any inconvenience, delay, or additional cost incurred by him on account of such operations by others.

11. TRAINMAN'S WALKWAYS:

- A. Along the outer side of each exterior track of multiple operated track, and on each side of single operated track, an unobstructed continuous space suitable for trainman's use in walking along trains, extending to a line not less than 10 feet from centerline of track, shall be maintained. Any temporary impediments to walkways and track drainage encroachments or obstructions allowed during work hours while Railroad's protective service is provided shall be removed before the close of each work day. If there is any excavation near the walkway, a handrail, with 10'-0" minimum clearance from centerline of track, shall be placed and must conform to AREMA and/or FRA standards.

12. GUIDELINES FOR PERSONNEL ON COMPANY'S CORRIDOR:

- A. The Contractor and/or the Department's personnel authorized to perform work on Company's corridor as specified in Section 2 above are not required to complete Norfolk Southern Roadway Worker Protection Training. However, the Contractor and the Department's personnel must be familiar with Norfolk Southern's standard operating rules and guidelines, should conduct themselves accordingly, and may be removed from the property for failure to follow these guidelines.
- B. All persons shall wear hard hats. Appropriate eye and hearing protection must be used. Working in shorts is prohibited. Shirts must cover shoulders, back and abdomen. Working in tennis or jogging shoes, sandals, boots with high heels, cowboy and other slip-on type boots is prohibited. Hard-sole, lace-up footwear, zippered boots or boots cinched up with straps which fit snugly about the ankle are adequate. Wearing of safety boots is strongly recommended. Reflective vests are also required within 25' of the centerline of any track and are strongly recommend to be worn in the vicinity of public roadways.
- C. No one is allowed within 25' of the centerline of track without specific authorization from the flagman.
- D. All persons working near track while train is passing are to lookout for dragging bands, chains and protruding or shifted cargo.
- E. No one is allowed to cross tracks without specific authorization from the flagman.
- F. All welders and cutting torches working within 25' of track must stop when train is passing.
- G. No steel tape or chain will be allowed to cross or touch rails without permission from the Railroad.

13. GUIDELINES FOR EQUIPMENT ON COMPANY RIGHT-OF-WAY:

- A. No crane or boom equipment will be allowed to set up to work or park within boom distance plus 15' of centerline of track without specific permission from Railroad official and flagman.
 - B. No crane or boom equipment will be allowed to foul track or lift a load over the track without flag protection and track time.
 - C. All employees will stay with their machines when crane or boom equipment is pointed toward track.
 - D. All cranes and boom equipment under load will stop work while train is passing (including pile driving).
 - E. Swinging loads must be secured to prevent movement while train is passing.
 - F. No loads will be suspended above a moving train.
 - G. No equipment will be allowed within 25' of centerline of track without specific authorization of the flagman.
 - H. Trucks, tractors or any equipment will not touch ballast line without specific permission from Railroad official and flagman. Orange construction fencing may be required as directed.
 - I. No equipment or load movement within 25' or above a standing train or Railroad equipment without specific authorization of the flagman.
 - J. All operating equipment within 25' of track must halt operations when a train is passing. All other operating equipment may be halted by the flagman if the flagman views the operation to be dangerous to the passing train.
 - K. All equipment, loads and cables are prohibited from touching rails.
 - L. While clearing and grubbing, no vegetation will be removed from Railroad embankment with heavy equipment without specific permission from the Railroad Engineer and flagman.
 - M. No equipment or materials will be parked or stored on Company's corridor or property unless specific authorization is granted from the Railroad Engineer.
 - N. All unattended equipment that is left parked on Company corridor or property shall be effectively immobilized so that it cannot be moved by unauthorized persons.
 - O. All cranes and boom equipment will be turned away from track after each work day or whenever unattended by an operator.
 - P. Prior to performing any crane operations, the Contractor shall establish a single point of contact for the Railroad flagman to remain in communication with at all times. Person must also be in direct contact with the individual(s) directing the crane operation(s).
14. **INSURANCE:**
- A. In addition to any other forms of insurance or bonds required under the terms of the contract and specifications, the Prime Contractor will be required to carry insurance of the following kinds and amounts:

ST-50

Project U-3109A

Alamance County

1. a. **Commercial General Liability Insurance** having a combined single limit of not less than \$2,000,000 per occurrence for all loss, damage, cost and expense, including attorneys' fees, arising out of bodily injury liability and property damage liability during the policy period. Said policy shall include explosion, collapse, and underground hazard (XCU) coverage, shall be endorsed to name Company and Railroad specified in item A.2.c. below both as the certificate holders and as an additional insureds, and shall include a severability of interests provision.
- b. **Automobile Liability Insurance** with a combined single limit of not less than \$1,000,000 each occurrence for injury to or death of persons and damage to or loss or destruction of property. Said policy or policies shall be endorsed to name Company and Railroad specified in item A.2.c. below both as the certificate holder and as an additional insured and shall include a severability of interests provision.
2. **Railroad Protective Liability Insurance** having a combined single limit of not less than \$2,000,000 each occurrence and \$6,000,000 in the aggregate applying separately to each annual period. If the project involves track over which passenger trains operate, the insurance limits required are not less than a combined single limit of \$5,000,000 each occurrence and \$10,000,000 in the aggregate applying separately to each annual period. Said policy shall provide coverage for all loss, damage or expense arising from bodily injury and property damage liability, and physical damage to property attributed to acts or omissions at the job site.

The standards for the Railroad Protective Liability Insurance are as follows:

- a. The insurer must be rated A- or better by A.M. Best Railroad, Inc.
NOTE: NS does not accept from insurers Chartis (AIG or Affiliated Company including Lexington Insurance Company), Hudson Group or Liberty or Affiliated Company, American Contractors Insurance Company and Erie Insurance Company including Erie Insurance Exchange and Erie Indemnity Company.
- b. The policy must be written using one of the following combinations of Insurance Services Office (“ISO”) Railroad Protective Liability Insurance Form Numbers:
 - (1) CG 00 35 01 96 and CG 28 31 10 93; or
 - (2) CG 00 35 07 98 and CG 28 31 07 98; or
 - (3) CG 00 35 10 01; or
 - (4) CG 00 35 12 04; or
 - (5) CG 00 35 12 07; or
 - (6) CG 00 35 04 13.
- c. The named insured on each policy as required to be issued to each Company and to Railroad shall read: (NOTE: The below insured is to be treated separately as an insured on each railroad protective policy for a total of (2) two separate policies being issued.)

ST-51

Project U-3109A

Alamance County

COMPANY

North Carolina Railroad Company 2809 Highwoods Boulevard
Raleigh, NC 27604-1000

Attn: Infrastructure Manager; and

(NOTE: Company does not share coverage on RRPL with any other entity on this policy)

RAILROAD

(As named in the Project Agreement with Project Department) Three Commercial Place
Norfolk, Virginia 23510-2191

Attn: S. W. Dickerson Risk Management

(NOTE: Railroad does not share coverage on RRPL with any other entity on this policy)

- d. The description of operations must appear on the Declarations, must match the project description in this agreement, and must include the appropriate Department project and contract identification numbers. The Description and Designation shall read:

Construct a new grade separation on the proposed new location of NC 119 running in a northerly direction over the tracks owned by North Carolina Railroad and operated by Norfolk Southern Railway Company in Alamance County, identified as State Project WBS 34900 (U-3109A) and Federal Project STP- 0119(10), and in connection therewith proposes to construct a crossing at separated grade, across the railroad right-of-way, tracks and other facilities.

- e. The job location must appear on the Declarations and must include the city, state, and appropriate highway name/number. **NOTE: Do not include any references to milepost, valuation station, or mile marker on the insurance policy.**
- f. The name and address of the prime Contractor must appear on the Declarations.
- g. The name and address of the Department must be identified on the Declarations as the “Involved Governmental Authority or Other Contracting Party.”
- h. Endorsements/forms that are required are:
 - (1) Physical damage to Property Amendment
 - (2) Terrorism Risk Insurance Act (TRIA) coverage must be included
- i. Other endorsements/forms that will be accepted are:
 - (1) Broad Form Nuclear Exclusion – Form IL 00 21
 - (2) 30-day Advance Notice of Non-renewal or cancellation
 - (3) Required State Cancellation Endorsement

ST-52

Project U-3109A

Alamance County

- (4) Quick Reference or Index Form CL/IL 240
- j. Endorsements/forms that are NOT acceptable are:
 - (1) Any Pollution Exclusion Endorsement except CG 28 31
 - (2) Any Punitive or Exemplary Damages Exclusion
 - (3) Known injury or Damage Exclusion form CG 00 59
 - (4) Any Common Policy Conditions form
 - (5) An Endorsement that limits or excludes Professional Liability coverage
 - (6) A Non-Cumulation of Liability of Pyramiding of Limits Endorsement
 - (7) An Endorsement that excludes TRIA coverage
 - (8) A Sole Agent Endorsement
 - (9) Any type of deductible endorsement of amendment
 - (10) Any other endorsement/form not specifically authorized in item no. 2.h above.

B. If any part of the work is sublet, similar insurance, and evidence thereof as specified in A.1 above, shall be provided by or on behalf of the subcontractor to cover its operations on Company's corridor.

C. All insurance required under the preceding subsection A shall be underwritten by insurers and be of such form and content, as may be acceptable to the Company and Railroad. Prior to entry on Company's corridor, the original Railroad Protective Liability Insurance Policy and one duplicate copy shall be submitted by the Prime Contractor to the Department at the address below for its review and transmittal to the Company and Railroad. In addition, certificates of insurance evidencing the Prime Contractor's and any subcontractors' Commercial General Liability Insurance shall be issued to the Company, the Railroad and the Department at the addresses below, and forwarded to the Department for its review and transmittal to the Company and the Railroad. The certificates of insurance shall state that the insurance coverage will not be suspended, voided, canceled, or reduced in coverage or limits without (30) days advance written notice to Company, Railroad and the Department. No work will be permitted by Railroad on the Company's corridor until both the Company and Railroad have reviewed and approved the evidence of insurance required herein.

DEPARTMENT:

NCDOT Rail Division
Engineering & Safety Branch
C/O State Railroad Agent
1556 Mail Service Center
Raleigh, NC 27699-1556

RAILROAD:

Risk Management
Norfolk Southern Railway Company
Three Commercial Place
Norfolk, Virginia 23510-2191

COMPANY:

North Carolina Railroad Company 2809 Highwoods
Boulevard
Raleigh, NC 27604

- D. The insurance required herein shall in no way serve to limit the liability of Department or its Contractors under the terms of this agreement.
- E. Insurance Submission Procedures
 - 1. Company and Railroad will only accept initial insurance submissions via US Mail or Overnight carrier to the addresses noted in C above. Company and Railroad will NOT accept initial insurance submissions via email or faxes. **Please provide point of contact information with the submission including a phone number and email address.**
 - 2. Company and Railroad requires the following two (2) forms of insurance in the initial insurance submission to be submitted under a cover letter providing details of the project and contact information. The Company and Railroad are to be treated separately as an insured on each insurance policy for a total of (2) two separate policies being issued.
 - a. The full original or certified true countersigned copy of the railroad protective liability insurance policy in its entirety inclusive of all declarations, schedule of forms and endorsements along with the policy forms and endorsements.
 - b. The Contractor's commercial general, automobile, and workers' compensation liability insurance certificate of liability insurance evidencing a combined single limit of a minimum of \$2M per occurrence of general and \$1M per occurrence of automobile liability insurance naming North Carolina Railroad Company, 2809 Highwoods Boulevard, Raleigh, 27604 and Norfolk Southern Railway Company, Three Commercial Place, Norfolk, VA 23510 as the certificate holders and as an additional insureds on both the general and automobile liability insurance policy.
 - 3. It should be noted that the Company and Railroad do not accept notation of Railroad Protective insurance on a certificate of liability insurance form or Binders as Company and Railroad must have the full original countersigned policy. Further, please note that mere receipt of the policy is not the only issue but review for compliance. Due to the number of projects system-wide, it typically takes a minimum of 30-45 days for the Railroad to review.
- F. The insurance amounts specified are minimum amounts and the Contractor may carry insurance in larger amounts if he so desires.
- G. All insurance herein before specified shall be carried until the final inspection and acceptance of the Project by the Department, Company and Railroad, or acceptance of that portion of the Project within Company's corridor. At this point, no work or any other activities by the Contractor shall take place in Company's corridor without written permission from the Department, Company and Railroad.

15. FAILURE TO COMPLY:

A. In the event the Contractor violates or fails to comply with any of the requirements of these Special Provisions:

1. The Railroad Engineer may require that the Contractor vacate Company's corridor.
2. The Department's Engineer may withhold all monies due the Contractor on monthly statements.

B. Any such orders shall remain in effect until the Contractor has remedied the situation to the satisfaction of the Railroad Engineer and the Department's Engineer.

16. PAYMENT FOR COST OF COMPLIANCE:

No separate payment will be made for any extra cost incurred on account of compliance with these special provisions. All such costs shall be included in prices bid for other items of the work as specified in the payment items.

17. COMPLETION AND ACCEPTANCE:

Upon completion of the work, the Contractor shall remove from within the limits of the Company's corridor all machinery, equipment, surplus materials, rubbish or temporary buildings of the Contractor, and leave said corridor in a neat and orderly condition. After the final inspection has been made and work found to be completed in a satisfactory manner acceptable to the Department, the Company and the Railroad, the Department will be notified of the Railroad's acceptance in writing by the **Railroad's** Chief Engineer or his authorized representative within ten (10) days or as soon thereafter as practicable.

ST-55

Project U-3109A

Alamance County

18. PROJECT INFORMATION

- | | |
|------------------------------|--------------------------|
| A. NS File No.: | BR0086234 |
| B. NCR/NS Milepost: | H-30.0 |
| C. Department's Project No.: | U-3109A, WBS 34900.3.GV2 |

ST-56

Project U-3109A

Alamance County

Norfolk Southern Check List for Construction

* to be completed prior to the start of any work on Norfolk Southern right-of-way

Norfolk Southern Milepost/File #: _____

Sponsor/DOT File #: _____

Norfolk Southern Public Improvement Contact: _____

Has contractor reviewed and agreed to be in compliance with the latest **Special Provisions for the Protection of Railway Interests**?

Has **Insurance** been approved by Norfolk Southern Risk Management Department (Scott Dickerson)? Date Approved: _____

Has a **Pre-Construction Meeting** been scheduled with a Norfolk Southern representative? Scheduled Date: _____

Has a **Construction Right-of-Entry** been executed by contractor and Norfolk Southern? Date Fully Executed: _____

Has a written **Authorization to Proceed** been issued by a Norfolk Southern representative? Date Issued _____

Has a **Flagman** been assigned? Name/Phone # _____

Signed by DOT Representative Date Signed by Contractor Date

Signed by NS Representative Date

Railroad Site Data:

The following information was received from the Railroad, and is provided as a convenience to the Contractor in bidding this project. This information is subject to change and the Contractor may, at his discretion, contact the Railroad directly to verify its current accuracy. Since this information is shown as a convenience to the Contractor, but is subject to change, the Contractor shall have no claims whatsoever against either the Railroad or the Department of Transportation for any delays or additional costs incurred based on changes in this information which occur after the above date of receipt.

Type and number of tracks within 50 ft. of project (mainline, branchline, siding, yard, etc.).

1 – Mainline

Number of trains on affected track per day.

14 – Passenger/Freight

Maximum authorized operating speed of trains.

79 mph

C-1

**Project Special Provisions
Culverts**

Table of Contents

| | Page # |
|--|-------------------|
| Optional Precast Reinforced Concrete Box Culvert at Stations 96+88.00 -L-, 179+55.00 -L- and 19+77.00 -Y10- (12-12-13) | ----- C-2 |
| Falsework and Formwork (4-5-12) | ----- C-9 |
| Submittal of Working Drawings (6-19-15) | ----- C-16 |
| Crane Safety (8-15-05) | ----- C-23 |
| Grout for Structures (9-30-11) | ----- C-24 |

3/21/2017



DocuSigned by:

 F245838930BF40E...

PROJECT SPECIAL PROVISIONS
CULVERTS

OPTIONAL PRECAST REINFORCED CONCRETE BOX (12-12-13)
CULVERT AT STATIONS 96+88.00 -L-, 179+55.00 -L- AND 19+77.00 -Y10-

1.0 GENERAL

This Special Provision covers the design, fabrication and construction of precast reinforced concrete box culverts intended for the conveyance of storm water.

If the option is indicated on the plans, the submittal for a precast reinforced box culvert in lieu of a cast-in-place culvert is permitted. Design the precast culvert sections in accordance with ASTM C1577 or the current edition of the AASHTO LRFD Bridge Design Specifications. Rate all sizes of precast reinforced concrete box culverts in accordance with the current edition of the AASHTO Manual for Bridge Evaluation. Ensure the culvert rates for the AASHTO design loads and North Carolina's legal loads (see Section 2.0 for North Carolina's legal loads). Provide the size and number of barrels as indicated on the plans. Detail the culvert with cast-in-place wings walls and footings. Precast wing walls and footings will not be allowed. Provide a precast box culvert that meets the requirements of Section 1077 and any other applicable parts of the Standard Specifications.

The design and rating of the precast and cast-in-place members is the responsibility of the Contractor and is subject to review, comments and approval. Submit two sets of detailed plans and rating sheets for review. Include all details in the plans, including the size and spacing of the required reinforcement necessary to build the precast box and cast-in-place members. Have a North Carolina Registered Professional Engineer check and seal the plans, rating sheets and design calculations. After the plans, rating sheets and design calculations are reviewed and, if necessary, the corrections made, submit one set of plans and rating sheets on 22" x 34" sheets to become part of the contract plans.

If the span, rise and design earth cover for the precast reinforced concrete box culvert are identical to a previously approved submittal, the Contractor may request the previously approved design calculations and plans be considered as the submittal for review and approval. However, a set of plans and rating sheets will need to be submitted to become part of the contract plans.

2.0 NORTH CAROLINA'S LEGAL LOADS

Apply the following legal loads to all structures carrying interstate traffic:

| SINGLE VEHICLE(SV) | | | TRUCK TRACTOR SEMI-TRAILER(TTST) | | |
|--------------------|---|-----------------|----------------------------------|--|--|
| REF. # | SCHEMATIC | | REF. # | SCHEMATIC | |
| SH | 5K | 20K 12.5 TON | T4A | 11K 7.5K 19K 19K 56.5K 28.25 TON | |
| S3A | 7.5K 19K 19K 22.75 TON | 45.5K | T5B | 6.5K 19K 19K 9.75K 9.75K 64K 32 TON | |
| S3C | 5K 19K 19K 21.5 TON | 43K | T6A | 11K 4K 19K 19K 9.5K 9.5K 72K 36 TON | |
| S4A | 11.5K 4K 19K 19K 26.75 TON | 53.5K | T7A | 11K 4K 19K 19K 9K 9K 9K 80K 40 TON | |
| S5A | 11K 6K 19K 19K 6K 30.5 TON | 61K | T7B | 11K 9.5K 9.5K 6K 6K 19K 19K 80K 40 TON | |
| S6A | 11K 6.66K 6.67K 19K 19K 6.67K 34.5 TON | 69K | | | |
| S7A | 11K 6.66K 6.67K 19K 19K 6.67K 11K 40 TON | 80K | | | |
| S7B | 11K 7K 7K 19K 19K 7K 7K 38.5 TON | 77K | | | |

Apply the following legal loads to all structures carrying non-interstate traffic:

| SINGLE VEHICLE (SV) | | TRUCK TRACTOR SEMI-TRAILER (TTST) | |
|---------------------|-----------|-----------------------------------|-----------|
| REF. # | SCHEMATIC | REF. # | SCHEMATIC |
| SNSH | | TNAGRIT3 | |
| SNGARBS2 | | TNT4A | |
| SNAGRIS2 | | TNAGRIT4 | |
| SNCOTTS3 | | TNAGT5A | |
| SNAGGRS4 | | TNAGT5B | |
| SNS5A | | TNT6A | |
| SNS6A | | TNT7A | |
| SNS7B | | TNT7B | |

3.0 PRECAST REINFORCED CONCRETE BOX SECTIONS

The precast reinforced concrete box culvert sections shall match the size and hydraulic opening indicated in the contract plans.

A. Design

1. Design Fill – The design earth cover is reported on the plans as the elevation difference between the point of maximum fill and the bottom of the top slab.
2. Placement of Reinforcement – Provide a 1 inch concrete cover over the reinforcement subject to the provisions of Section F. Extend the inside reinforcement into the tongue portion of the joint and the outside reinforcement into the groove portion of the joint. Detail the clear distance of the end wires so it is not less than 1/2 inch or more than 2 inches from the ends of the box section. Assemble reinforcement per the requirements of ASTM C1577 or the approved design. The exposure of the ends of the wires used to position the reinforcement is not a cause for rejection.
3. Laps and Spacing – Use lap splices for the transverse reinforcement. Detail the transverse wires so that the center to center spacing is not less than 2 inches or more than 4 inches. Do not detail the longitudinal wires with a center to center spacing of more than 8 inches.

B. Joints

1. Produce the precast reinforced concrete box section with tongue and groove ends. Design and form these ends of the box section so, when the sections are laid together, they make a continuous line of box sections with a smooth interior free of appreciable irregularities in the flowline, all compatible with the permissible variations given in Section F. The internal joint formed at the tongue and groove ends of the precast units shall be sealed with either bitumen/butyl sealant or closed-cell neoprene material. The internal joint material shall be installed in accordance with the manufacturer's recommendations. The material shall be shown on the shop drawings when they are submitted for review.
2. Seal the external joint with an outside sealer wrap conforming to ASTM C877 that is at least 12 inches wide and covers the joint on both the sides and the top of the box section. Use ConWrap CS-212 from Concrete Sealants, Inc., EZ-Wrap from Press-Seal Gasket Corporation, Seal Wrap from Mar-Mac Manufacturing Co., Inc., Cadilloc External Pipe Joint from Cadilloc, or an approved equal for the outside sealer wrap. If the outside sealer wrap is not applied in a continuous strip along the entire joint, a 12 inch minimum lap of the outside sealer wrap is permitted. Before placing the outside sealer wrap, clean and prime the area receiving the outside sealer wrap in accordance with the sealer wrap manufacturer recommendations. The joint wrap manufacturer installation recommendations shall be included with shop drawings submitted for review. The external joint wrap shall be installed in pieces, as indicated on Figure 1 below:

C-6

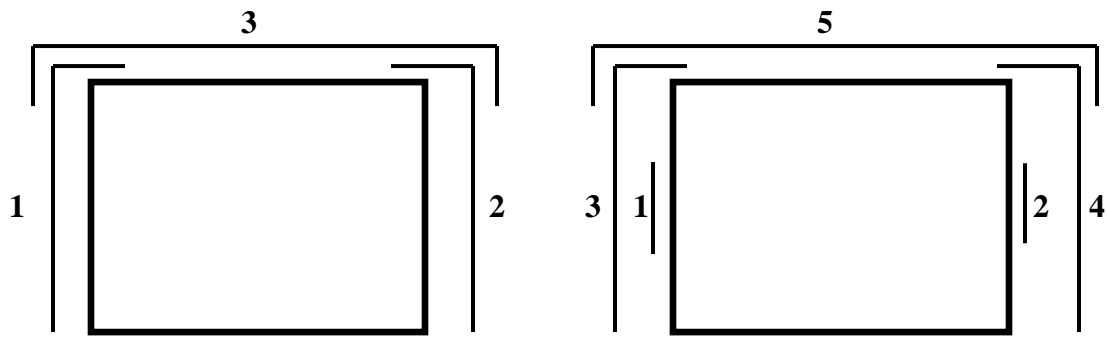
**Figure 1**

Cover the external joint sealer with a 3 foot strip of filter fabric conforming to Type 4 requirements in Section 1056 of the Standard Specifications.

Place multiple lines of a precast reinforced concrete box culvert such that the longitudinal joint between the sections has a minimum width of 3 inches. Fill the joint between multiple lines of precast box sections with Class A concrete. Use Class A concrete that meets the requirements listed in the Standard Specifications except that Field Compressive Strength Specimens are not required.

C. Manufacture

Manufacture precast reinforced concrete box culvert sections by either the wet cast method or dry cast method.

1. Mixture – In addition to the requirements of Section 1077 of the Standard Specifications, do not proportion the mix with less than 564 lb/yd³ of portland cement.
2. Strength – Concrete shall develop a minimum 28-day compressive strength of 5000 psi. Movement of the precast sections should be minimized during the initial curing period. Any damage caused by moving or handling during the initial curing phase will be grounds for rejection of that precast section.
3. Air Entrainment – Air entrain the concrete in accordance with Section 1077 - 5(A) of the Standard Specifications. For dry cast manufacturing, air entrainment is not required.
4. Testing – Test the concrete in accordance with the requirements of Section 1077 - 5(B).
5. Handling – Handling devices or holes are permitted in each box section for the purpose of handling and placing. Submit details of handling devices or holes for approval and do not cast any concrete until approval is granted. Remove all

C-7

handling devices flush with concrete surfaces as directed. Fill holes in a neat and workmanlike manner with an approved non-metallic non-shrink grout, concrete, or hole plug.

D. Physical Requirements

Acceptability of precast culvert sections is based on concrete cylinders made and tested in accordance with ASTM C31 and ASTM C39.

E. Permissible Variations

1. Flatness – All external surfaces shall be flat, true, and plumb. Irregularities, depressions, or high spots on all external surfaces shall not exceed 1/2 inch in 8 feet.
2. Internal Dimensions – Produce sections so that the internal and haunch dimensions do not vary more than 1/4 inch from the plan dimensions.
3. Adjacent Sections - Internal, external, and haunch dimensions for connecting sections shall not vary more than 1/2 inch.
4. Length of Tongue and Groove – The minimum length of the tongue shall be 4 inches. The minimum length of the groove shall be 4 inches. The dimensions of the tongue and groove shall not vary more than 1/4 inch from the plan dimensions.
5. Slab and Wall Thickness – Produce sections so that the slab and wall thickness are not less than that shown on the plans by more than 5% or 3/16 inch, whichever is greater. A thickness more than that required on the plans is not a cause for rejection.
6. Length of Opposite Surfaces – Produce sections so that variations in laying lengths of two opposite surfaces of the box section meet the requirements of ASTM C1577, Section 11.3.
7. Length of Section – Produce sections so that the underrun in length of a section is not more than 1/2 inch in any box section.
8. Position of Reinforcement – Produce sections so that the maximum variation in the position of the reinforcement is $\pm 3/8$ inch for slab and wall thicknesses of 5 inches or less and $\pm 1/2$ inch for slab and wall thicknesses greater than 5 inches. Produce sections so that the concrete cover is never less than 5/8 inch as measured to the internal surface or the external surface. The preceding minimum cover limitations do not apply at the mating surfaces of the joint.
9. Area of Reinforcement – Use the design steel shown on the plans for the steel reinforcement. Steel areas greater than those required are not cause for rejection. The permissible variation in diameter of any wire in finished fabric is prescribed for the wire before fabrication by either AASHTO M32 or M225.

C-8

F. Marking

1. Each section shall be match-marked in order of intended installation as indicated on the approved shop drawings. Ensure that pieces fit together neatly and in a workmanlike manner. In order to ensure a good, neat field fit, the Department will verify assembly of the first five adjacent sections or 20% of the total culvert length, whichever is greater, at the producer's facility and match-mark the pieces. This will require that a minimum of three adjacent sections of the culvert be fitted at the production yard at a time and then match-marked. Once three sections have been match-marked, the first section may be removed for shipment and a fourth section set for marking. Continue in a progressive manner until all sections have been properly match-marked. The producer shall document the GO-NO-GO dimensional measurements of each box culvert section produced through the post-pour inspection process.
2. Clearly mark each section of the box culvert in accordance with ASTM C1577, Section 15. The information requirements of Section 15.1 shall be clearly marked on the inner surface of each section.

G. Construction

1. Pre-installation Meeting – A pre-installation meeting is required prior to installation. Representatives from the Contractor, the precast box manufacturer, and the Department should attend this meeting. The precast box manufacturer representative shall be on site during installation.
2. Foundation – Foundation for precast box culvert shall meet the requirements of Section 414 of the Standard Specifications. In addition, Type VI foundation material shall be encapsulated in filter fabric conforming to Type 4 requirements in Section 1056 of the Standard Specifications. The filter fabric shall be placed perpendicular to the culvert barrel. Provide sufficient overhang beyond the excavation to allow a minimum lap of 3 feet when the foundation material is placed and fabric wrapped on top. Perpendicular sections of fabric shall be continuous. A minimum lap of 2 feet shall be provided between sections of fabric.
3. Installation – Sections shall be placed at the beginning of the outlet end of the culvert with the groove end being laid upgrade. Tongue sections shall be laid into the groove sections. Positive means shall be provided to pull each section firmly into the previously placed section so that the joints are tightly homed. Use a "come-along", box pullers or other approved methods to create a positive means of joining box sections. Construction equipment shall not have direct contact with the box section. The load of the box shall be suspended by lifting device during joining procedure.
4. Backfill – Complete backfill in accordance with Section 414 of the Standard Specifications.

4.0 BASIS OF PAYMENT

Any additional cost of redesigning will be paid for by the Contractor if Precast Reinforced Concrete Culvert is used in lieu of the cast-in-place culvert shown on the plans. Except for Foundation Conditioning Material and Culvert Excavation, payment for the Precast Box Culvert will be a lump sum amount equal to the payment that would be allowed for construction of a Cast-in-Place Box Culvert. Plan quantities and unit bid prices will be used to compute the lump sum amount. Such price and payment will be full compensation for all work covered by this Special Provision, the plans and applicable parts of the Standard Specifications and will include, but not be limited to, furnishing all labor, materials (including all filter fabric), equipment and other incidentals necessary to complete this work. Such price and payment will also be full compensation for concrete, reinforcing steel, labor, equipment and all other related materials necessary for the completion of the barrel section, and the construction of the headwalls, leveling pad, end curtain walls, wings and wing footings.

FALSEWORK AND FORMWORK

(4-5-12)

1.0 DESCRIPTION

Use this Special Provision as a guide to develop temporary works submittals required by the Standard Specifications or other provisions; no additional submittals are required herein. Such temporary works include, but are not limited to, falsework and formwork.

Falsework is any temporary construction used to support the permanent structure until it becomes self-supporting. Formwork is the temporary structure or mold used to retain plastic or fluid concrete in its designated shape until it hardens. Access scaffolding is a temporary structure that functions as a work platform that supports construction personnel, materials, and tools, but is not intended to support the structure. Scaffolding systems that are used to temporarily support permanent structures (as opposed to functioning as work platforms) are considered to be falsework under the definitions given. Shoring is a component of falsework such as horizontal, vertical, or inclined support members. Where the term "temporary works" is used, it includes all of the temporary facilities used in bridge construction that do not become part of the permanent structure.

Design and construct safe and adequate temporary works that will support all loads imposed and provide the necessary rigidity to achieve the lines and grades shown on the plans in the final structure.

C-10

2.0 MATERIALS

Select materials suitable for temporary works; however, select materials that also ensure the safety and quality required by the design assumptions. The Engineer has authority to reject material on the basis of its condition, inappropriate use, safety, or nonconformance with the plans. Clearly identify allowable loads or stresses for all materials or manufactured devices on the plans. Revise the plan and notify the Engineer if any change to materials or material strengths is required.

3.0 DESIGN REQUIREMENTS**A. Working Drawings**

Provide working drawings for items as specified in the contract, or as required by the Engineer, with design calculations and supporting data in sufficient detail to permit a structural and safety review of the proposed design of the temporary work.

On the drawings, show all information necessary to allow the design of any component to be checked independently as determined by the Engineer.

When concrete placement is involved, include data such as the drawings of proposed sequence, rate of placement, direction of placement, and location of all construction joints. Submit the number of copies as called for by the contract.

When required, have the drawings and calculations prepared under the guidance of, and sealed by, a North Carolina Registered Professional Engineer who is knowledgeable in temporary works design.

If requested by the Engineer, submit with the working drawings manufacturer's catalog data listing the weight of all construction equipment that will be supported on the temporary work. Show anticipated total settlements and/or deflections of falsework and forms on the working drawings. Include falsework footing settlements, joint take-up, and deflection of beams or girders.

As an option for the Contractor, overhang falsework hangers may be uniformly spaced, at a maximum of 36 inches, provided the following conditions are met:

| Member Type (PCG) | Member Depth, (inches) | Max. Overhang Width, (inches) | Max. Slab Edge Thickness, (inches) | Max. Screenshot Wheel Weight, (lbs.) | Bracket Min. Vertical Leg Extension, (inches) |
|-------------------|------------------------|-------------------------------|------------------------------------|--------------------------------------|---|
| II | 36 | 39 | 14 | 2000 | 26 |
| III | 45 | 42 | 14 | 2000 | 35 |
| IV | 54 | 45 | 14 | 2000 | 44 |
| MBT | 63 | 51 | 12 | 2000 | 50 |
| MBT | 72 | 55 | 12 | 1700 | 48 |

C-11

Overhang width is measured from the centerline of the girder to the edge of the deck slab.

For Type II, III & IV prestressed concrete girders (PCG), 45-degree cast-in-place half hangers and rods must have a minimum safe working load of 6,000 lbs.

For MBT prestressed concrete girders, 45-degree angle holes for falsework hanger rods shall be cast through the girder top flange and located, measuring along the top of the member, 1'-2½" from the edge of the top flange. Hanger hardware and rods must have a minimum safe working load of 6,000 lbs.

The overhang bracket provided for the diagonal leg shall have a minimum safe working load of 3,750 lbs. The vertical leg of the bracket shall extend to the point that the heel bears on the girder bottom flange, no closer than 4 inches from the bottom of the member. However, for 72-inch members, the heel of the bracket shall bear on the web, near the bottom flange transition.

Provide adequate overhang falsework and determine the appropriate adjustments for deck geometry, equipment, casting procedures and casting conditions.

If the optional overhang falsework spacing is used, indicate this on the falsework submittal and advise the girder producer of the proposed details. Failure to notify the Engineer of hanger type and hanger spacing on prestressed concrete girder casting drawings may delay the approval of those drawings.

Falsework hangers that support concentrated loads and are installed at the edge of thin top flange concrete girders (such as bulb tee girders) shall be spaced so as not to exceed 75% of the manufacturer's stated safe working load. Use of dual leg hangers (such as Meadow Burke HF-42 and HF-43) are not allowed on concrete girders with thin top flanges. Design the falsework and forms supporting deck slabs and overhangs on girder bridges so that there will be no differential settlement between the girders and the deck forms during placement of deck concrete.

When staged construction of the bridge deck is required, detail falsework and forms for screed and fluid concrete loads to be independent of any previous deck pour components when the mid-span girder deflection due to deck weight is greater than ¾".

Note on the working drawings any anchorages, connectors, inserts, steel sleeves or other such devices used as part of the falsework or formwork that remains in the permanent structure. If the plan notes indicate that the structure contains the necessary corrosion protection required for a Corrosive Site, epoxy coat, galvanize or metalize these devices. Electroplating will not be allowed. Any coating required by the Engineer will be considered incidental to the various pay items requiring temporary works.

Design falsework and formwork requiring submittals in accordance with the 1995 AASHTO *Guide Design Specifications for Bridge Temporary Works* except as noted herein.

C-12

1. Wind Loads

Table 2.2 of Article 2.2.5.1 is modified to include wind velocities up to 110 mph. In addition, Table 2.2A is included to provide the maximum wind speeds by county in North Carolina.

Table 2.2 - Wind Pressure Values

| Height Zone feet above ground | Pressure, lb/ft ² for Indicated Wind Velocity, mph | | | | |
|----------------------------------|---|----|----|-----|-----|
| | 70 | 80 | 90 | 100 | 110 |
| 0 to 30 | 15 | 20 | 25 | 30 | 35 |
| 30 to 50 | 20 | 25 | 30 | 35 | 40 |
| 50 to 100 | 25 | 30 | 35 | 40 | 45 |
| over 100 | 30 | 35 | 40 | 45 | 50 |

2. Time of Removal

The following requirements replace those of Article 3.4.8.2.

Do not remove forms until the concrete has attained strengths required in Article 420-16 of the Standard Specifications and these Special Provisions.

Do not remove forms until the concrete has sufficient strength to prevent damage to the surface.

Table 2.2A - Steady State Maximum Wind Speeds by Counties in North Carolina

| COUNTY | 25 YR (mph) | COUNTY | 25 YR (mph) | COUNTY | 25 YR (mph) |
|------------|----------------|-------------|----------------|--------------|----------------|
| Alamance | 70 | Franklin | 70 | Pamlico | 100 |
| Alexander | 70 | Gaston | 70 | Pasquotank | 100 |
| Alleghany | 70 | Gates | 90 | Pender | 100 |
| Anson | 70 | Graham | 80 | Perquimans | 100 |
| Ashe | 70 | Granville | 70 | Person | 70 |
| Avery | 70 | Greene | 80 | Pitt | 90 |
| Beaufort | 100 | Guilford | 70 | Polk | 80 |
| Bertie | 90 | Halifax | 80 | Randolph | 70 |
| Bladen | 90 | Harnett | 70 | Richmond | 70 |
| Brunswick | 100 | Haywood | 80 | Robeson | 80 |
| Buncombe | 80 | Henderson | 80 | Rockingham | 70 |
| Burke | 70 | Hertford | 90 | Rowan | 70 |
| Cabarrus | 70 | Hoke | 70 | Rutherford | 70 |
| Caldwell | 70 | Hyde | 110 | Sampson | 90 |
| Camden | 100 | Iredell | 70 | Scotland | 70 |
| Carteret | 110 | Jackson | 80 | Stanley | 70 |
| Caswell | 70 | Johnston | 80 | Stokes | 70 |
| Catawba | 70 | Jones | 100 | Surry | 70 |
| Cherokee | 80 | Lee | 70 | Swain | 80 |
| Chatham | 70 | Lenoir | 90 | Transylvania | 80 |
| Chowan | 90 | Lincoln | 70 | Tyrell | 100 |
| Clay | 80 | Macon | 80 | Union | 70 |
| Cleveland | 70 | Madison | 80 | Vance | 70 |
| Columbus | 90 | Martin | 90 | Wake | 70 |
| Craven | 100 | McDowell | 70 | Warren | 70 |
| Cumberland | 80 | Mecklenburg | 70 | Washington | 100 |
| Currituck | 100 | Mitchell | 70 | Watauga | 70 |
| Dare | 110 | Montgomery | 70 | Wayne | 80 |
| Davidson | 70 | Moore | 70 | Wilkes | 70 |
| Davie | 70 | Nash | 80 | Wilson | 80 |
| Duplin | 90 | New Hanover | 100 | Yadkin | 70 |
| Durham | 70 | Northampton | 80 | Yancey | 70 |
| Edgecombe | 80 | Onslow | 100 | | |
| Forsyth | 70 | Orange | 70 | | |

C-14

B. Review and Approval

The Engineer is responsible for the review and approval of temporary works' drawings.

Submit the working drawings sufficiently in advance of proposed use to allow for their review, revision (if needed), and approval without delay to the work.

The time period for review of the working drawings does not begin until complete drawings and design calculations, when required, are received by the Engineer.

Do not start construction of any temporary work for which working drawings are required until the drawings have been approved. Such approval does not relieve the Contractor of the responsibility for the accuracy and adequacy of the working drawings.

4.0 CONSTRUCTION REQUIREMENTS

All requirements of Section 420 of the Standard Specifications apply.

Construct temporary works in conformance with the approved working drawings. Ensure that the quality of materials and workmanship employed is consistent with that assumed in the design of the temporary works. Do not weld falsework members to any portion of the permanent structure unless approved. Show any welding to the permanent structure on the approved construction drawings.

Provide tell-tales attached to the forms and extending to the ground, or other means, for accurate measurement of falsework settlement. Make sure that the anticipated compressive settlement and/or deflection of falsework does not exceed 1 inch. For cast-in-place concrete structures, make sure that the calculated deflection of falsework flexural members does not exceed 1/240 of their span regardless of whether or not the deflection is compensated by camber strips.

A. Maintenance and Inspection

Inspect and maintain the temporary work in an acceptable condition throughout the period of its use. Certify that the manufactured devices have been maintained in a condition to allow them to safely carry their rated loads. Clearly mark each piece so that its capacity can be readily determined at the job site.

Perform an in-depth inspection of an applicable portion(s) of the temporary works, in the presence of the Engineer, not more than 24 hours prior to the beginning of each concrete placement. Inspect other temporary works at least once a month to ensure that they are functioning properly. Have a North Carolina Registered Professional Engineer inspect the cofferdams, shoring, sheathing, support of excavation structures, and support systems for load tests prior to loading.

C-15

B. Foundations

Determine the safe bearing capacity of the foundation material on which the supports for temporary works rest. If required by the Engineer, conduct load tests to verify proposed bearing capacity values that are marginal or in other high-risk situations.

The use of the foundation support values shown on the contract plans of the permanent structure is permitted if the foundations are on the same level and on the same soil as those of the permanent structure.

Allow for adequate site drainage or soil protection to prevent soil saturation and washout of the soil supporting the temporary works supports.

If piles are used, the estimation of capacities and later confirmation during construction using standard procedures based on the driving characteristics of the pile is permitted. If preferred, use load tests to confirm the estimated capacities; or, if required by the Engineer conduct load tests to verify bearing capacity values that are marginal or in other high risk situations.

The Engineer reviews and approves the proposed pile and soil bearing capacities.

5.0 REMOVAL

Unless otherwise permitted, remove and keep all temporary works upon completion of the work. Do not disturb or otherwise damage the finished work.

Remove temporary works in conformance with the contract documents. Remove them in such a manner as to permit the structure to uniformly and gradually take the stresses due to its own weight.

6.0 METHOD OF MEASUREMENT

Unless otherwise specified, temporary works will not be directly measured.

7.0 BASIS OF PAYMENT

Payment at the contract unit prices for the various pay items requiring temporary works will be full compensation for the above falsework and formwork.

SUBMITTAL OF WORKING DRAWINGS**(6-19-15)****1.0 GENERAL**

Submit working drawings in accordance with Article 105-2 of the *Standard Specifications* and this provision. For this provision, “submittals” refers to only those listed in this provision. The list of submittals contained herein does not represent a list of required submittals for the project. Submittals are only necessary for those items as required by the contract. Make submittals that are not specifically noted in this provision directly to the Engineer. Either the Structures Management Unit or the Geotechnical Engineering Unit or both units will jointly review submittals.

If a submittal contains variations from plan details or specifications or significantly affects project cost, field construction or operations, discuss the submittal with and submit all copies to the Engineer. State the reason for the proposed variation in the submittal. To minimize review time, make sure all submittals are complete when initially submitted. Provide a contact name and information with each submittal. Direct any questions regarding submittal requirements to the Engineer, Structures Management Unit contacts or the Geotechnical Engineering Unit contacts noted below.

In order to facilitate in-plant inspection by NCDOT and approval of working drawings, provide the name, address and telephone number of the facility where fabrication will actually be done if different than shown on the title block of the submitted working drawings. This includes, but is not limited to, precast concrete items, prestressed concrete items and fabricated steel or aluminum items.

2.0 ADDRESSES AND CONTACTS

For submittals to the Structures Management Unit, use the following addresses:

Via US mail:

Mr. T. K. Koch, P. E.
State Structures Engineer
North Carolina Department of
Transportation
Structures Management Unit
1581 Mail Service Center
Raleigh, NC 27699-1581

Attention: Mr. P. D. Lambert, P. E.

Via other delivery service:

Mr. T. K. Koch, P. E.
State Structures Engineer
North Carolina Department of
Transportation
Structures Management Unit
1000 Birch Ridge Drive
Raleigh, NC 27610

Attention: Mr. P. D. Lambert, P. E.

C-17

Submittals may also be made via email. Send submittals to:

plambert@ncdot.gov

(Paul Lambert)

Send an additional e-copy of the submittal to the following addresses:

jgaither@ncdot.ov

(James Gaither)

mrorie@ncdot.gov

(Madonna Rorie)

For submittals to the Geotechnical Engineering Unit, use the following addresses:

For projects in Divisions 1-7, use the following Eastern Regional Office address:

Via US mail:

Mr. K. J. Kim, Ph. D., P. E.
Eastern Regional Geotechnical
Manager
North Carolina Department of
Transportation
Geotechnical Engineering Unit -
Eastern Regional Office
1570 Mail Service Center
Raleigh, NC 27699-1570

Via other delivery service:

Mr. K. J. Kim, Ph. D., P. E.
Eastern Regional Geotechnical
Manager
North Carolina Department of
Transportation
Geotechnical Engineering Unit -
Eastern Regional Office
3301 Jones Sausage Road, Suite 100
Garner, NC 27529

For projects in Divisions 8-14, use the following Western Regional Office address:

Via US mail:

Mr. Eric Williams, P. E.
Western Regional Geotechnical
Manager
North Carolina Department of
Transportation
Geotechnical Engineering Unit -
Western Regional Office
5253 Z Max Boulevard
Harrisburg, NC 28075

Via other delivery service:

Mr. Eric Williams, P. E.
Western Regional Geotechnical
Manager
North Carolina Department of
Transportation
Geotechnical Engineering Unit -
Western Regional Office
5253 Z Max Boulevard
Harrisburg, NC 28075

The status of the review of structure-related submittals sent to the Structures Management Unit can be viewed from the Unit's web site, via the "Drawing Submittal Status" link.

Direct any questions concerning submittal review status, review comments or drawing markups to the following contacts:

Primary Structures Contact:

Paul Lambert (919) 707-6407
(919) 250-4082 facsimile

Secondary Structures Contacts:

James Gaither (919) 707-6409
Madonna Rorie (919) 707-6508

C-18

Eastern Regional Geotechnical Contact (Divisions 1-7):

K. J. Kim (919) 662-4710
 (919) 662-3095 facsimile
kkim@ncdot.gov

Western Regional Geotechnical Contact (Divisions 8-14):

Eric Williams (704) 455-8902
 (704) 455-8912 facsimile
ewilliams3@ncdot.gov

3.0 SUBMITTAL COPIES

Furnish one complete copy of each submittal, including all attachments, to the Engineer. At the same time, submit the number of hard copies shown below of the same complete submittal directly to the Structures Management Unit and/or the Geotechnical Engineering Unit.

The first table below covers “Structure Submittals”. The Engineer will receive review comments and drawing markups for these submittals from the Structures Management Unit. The second table in this section covers “Geotechnical Submittals”. The Engineer will receive review comments and drawing markups for these submittals from the Geotechnical Engineering Unit.

Unless otherwise required, submit one set of supporting calculations to either the Structures Management Unit or the Geotechnical Engineering Unit unless both units require submittal copies in which case submit a set of supporting calculations to each unit. Provide additional copies of any submittal as directed.

STRUCTURE SUBMITTALS

| Submittal | Copies Required by Structures Management Unit | Copies Required by Geotechnical Engineering Unit | Contract Reference Requiring Submittal ¹ |
|------------------------------------|--|---|--|
| Arch Culvert Falsework | 5 | 0 | Plan Note, SN Sheet & “Falsework and Formwork” |
| Box Culvert Falsework ⁷ | 5 | 0 | Plan Note, SN Sheet & “Falsework and Formwork” |
| Cofferdams | 6 | 2 | Article 410-4 |
| Foam Joint Seals ⁶ | 9 | 0 | “Foam Joint Seals” |

STRUCTURE SUBMITTALS

| Submittal | Copies Required by Structures Management Unit | Copies Required by Geotechnical Engineering Unit | Contract Reference Requiring Submittal ¹ |
|---|--|---|--|
| Expansion Joint Seals (hold down plate type with base angle) | 9 | 0 | “Expansion Joint Seals” |
| Expansion Joint Seals (modular) | 2, then 9 | 0 | “Modular Expansion Joint Seals” |
| Expansion Joint Seals (strip seals) | 9 | 0 | “Strip Seals” |
| Falsework & Forms ² (substructure) | 8 | 0 | Article 420-3 & “Falsework and Formwork” |
| Falsework & Forms (superstructure) | 8 | 0 | Article 420-3 & “Falsework and Formwork” |
| Girder Erection over Railroad | 5 | 0 | Railroad Provisions |
| Maintenance and Protection of Traffic Beneath Proposed Structure | 8 | 0 | “Maintenance and Protection of Traffic Beneath Proposed Structure at Station ____” |
| Metal Bridge Railing | 8 | 0 | Plan Note |
| Metal Stay-in-Place Forms | 8 | 0 | Article 420-3 |
| Metalwork for Elastomeric Bearings ^{4,5} | 7 | 0 | Article 1072-8 |
| Miscellaneous Metalwork ^{4,5} | 7 | 0 | Article 1072-8 |
| Disc Bearings ⁴ | 8 | 0 | “Disc Bearings” |
| Overhead and Digital Message Signs (DMS) (metalwork and foundations) | 13 | 0 | Applicable Provisions |
| Placement of Equipment on Structures (cranes, etc.) | 7 | 0 | Article 420-20 |
| Precast Concrete Box Culverts | 2, then 1 reproducible | 0 | “Optional Precast Reinforced Concrete Box |

STRUCTURE SUBMITTALS

| Submittal | Copies Required by Structures Management Unit | Copies Required by Geotechnical Engineering Unit | Contract Reference Requiring Submittal ¹ |
|--|--|---|--|
| | | | Culvert at Station ____” |
| Prestressed Concrete Cored Slab (detensioning sequences) ³ | 6 | 0 | Article 1078-11 |
| Prestressed Concrete Deck Panels | 6 and 1 reproducible | 0 | Article 420-3 |
| Prestressed Concrete Girder (strand elongation and detensioning sequences) | 6 | 0 | Articles 1078-8 and 1078-11 |
| Removal of Existing Structure over Railroad | 5 | 0 | Railroad Provisions |
| Revised Bridge Deck Plans (adaptation to prestressed deck panels) | 2, then 1 reproducible | 0 | Article 420-3 |
| Revised Bridge Deck Plans (adaptation to modular expansion joint seals) | 2, then 1 reproducible | 0 | “Modular Expansion Joint Seals” |
| Sound Barrier Wall (precast items) | 10 | 0 | Article 1077-2 & “Sound Barrier Wall” |
| Sound Barrier Wall Steel Fabrication Plans ⁵ | 7 | 0 | Article 1072-8 & “Sound Barrier Wall” |
| Structural Steel ⁴ | 2, then 7 | 0 | Article 1072-8 |
| Temporary Detour Structures | 10 | 2 | Article 400-3 & “Construction, Maintenance and Removal of Temporary Structure at Station ____” |
| TFE Expansion Bearings ⁴ | 8 | 0 | Article 1072-8 |

FOOTNOTES

1. References are provided to help locate the part of the contract where the submittals are required. References in quotes refer to the provision by that name. Articles refer to the *Standard Specifications*.
2. Submittals for these items are necessary only when required by a note on plans.
3. Submittals for these items may not be required. A list of pre-approved sequences is available from the producer or the Materials & Tests Unit.
4. The fabricator may submit these items directly to the Structures Management Unit.
5. The two sets of preliminary submittals required by Article 1072-8 of the *Standard Specifications* are not required for these items.
6. Submittals for Fabrication Drawings are not required. Submittals for Catalogue Cuts of Proposed Material are required. See Section 5.A of the referenced provision.
7. Submittals are necessary only when the top slab thickness is 18" or greater.

GEOTECHNICAL SUBMITTALS

| Submittal | Copies Required by Geotechnical Engineering Unit | Copies Required by Structures Management Unit | Contract Reference Requiring Submittal ¹ |
|---|---|--|--|
| Drilled Pier Construction Plans ² | 1 | 0 | Subarticle 411-3(A) |
| Crosshole Sonic Logging (CSL) Reports ² | 1 | 0 | Subarticle 411-5(A)(2) |
| Pile Driving Equipment Data Forms ^{2,3} | 1 | 0 | Subarticle 450-3(D)(2) |
| Pile Driving Analyzer (PDA) Reports ² | 1 | 0 | Subarticle 450-3(F)(3) |
| Retaining Walls ⁴ | 8 drawings, 2 calculations | 2 drawings | Applicable Provisions |
| Temporary Shoring ⁴ | 5 drawings, 2 calculations | 2 drawings | “Temporary Shoring” & “Temporary Soil Nail Walls” |

FOOTNOTES

1. References are provided to help locate the part of the contract where the submittals are required. References in quotes refer to the provision by that name. Subarticles refer to the *Standard Specifications*.
2. Submit one hard copy of submittal to the Engineer. Submit a second copy of submittal electronically (PDF via email) or by facsimile, US mail or other delivery service to the appropriate Geotechnical Engineering Unit regional office. Electronic submission is preferred.
3. The Pile Driving Equipment Data Form is available from:
https://connect.ncdot.gov/resources/Geological/Pages/Geotech_Forms_Details.aspx
See second page of form for submittal instructions.
4. Electronic copy of submittal is required. See referenced provision.

CRANE SAFETY**(8-15-05)**

Comply with the manufacturer specifications and limitations applicable to the operation of any and all cranes and derricks. Prime contractors, sub-contractors, and fully operated rental companies shall comply with the current Occupational Safety and Health Administration regulations (OSHA).

Submit all items listed below to the Engineer prior to beginning crane operations involving critical lifts. A critical lift is defined as any lift that exceeds 75 percent of the manufacturer's crane chart capacity for the radius at which the load will be lifted or requires the use of more than one crane. Changes in personnel or equipment must be reported to the Engineer and all applicable items listed below must be updated and submitted prior to continuing with crane operations.

CRANE SAFETY SUBMITTAL LIST

- A. **Competent Person:** Provide the name and qualifications of the "Competent Person" responsible for crane safety and lifting operations. The named competent person will have the responsibility and authority to stop any work activity due to safety concerns.
- B. **Riggers:** Provide the qualifications and experience of the persons responsible for rigging operations. Qualifications and experience should include, but not be limited to, weight calculations, center of gravity determinations, selection and inspection of sling and rigging equipment, and safe rigging practices.
- C. **Crane Inspections:** Inspection records for all cranes shall be current and readily accessible for review upon request.
- D. **Certifications:** **By July 1, 2006**, crane operators performing critical lifts shall be certified by NC CCO (National Commission for the Certification of Crane Operators), or satisfactorily complete the Carolinas AGC's Professional Crane Operator's Proficiency Program. Other approved nationally accredited programs will be considered upon request. All crane operators shall also have a current CDL medical card. Submit a list of anticipated critical lifts and corresponding crane operator(s). Include current certification for the type of crane operated (small hydraulic, large hydraulic, small lattice, large lattice) and medical evaluations for each operator.

GROUT FOR STRUCTURES**(9-30-11)****1.0 DESCRIPTION**

This special provision addresses grout for use in pile blockouts, grout pockets, shear keys, dowel holes and recesses for structures. This provision does not apply to grout placed in post-tensioning ducts for bridge beams, girders, or decks. Mix and place grout in accordance with the manufacturer's recommendations, the applicable sections of the Standard Specifications and this provision.

2.0 MATERIAL REQUIREMENTS

Use a Department approved pre-packaged, non-shrink, non-metallic grout. Contact the Materials and Tests Unit for a list of approved pre-packaged grouts and consult the manufacturer to determine if the pre-packaged grout selected is suitable for the required application.

When using an approved pre-packaged grout, a grout mix design submittal is not required.

The grout shall be free of soluble chlorides and contain less than one percent soluble sulfate. Supply water in compliance with Article 1024-4 of the Standard Specifications.

Aggregate may be added to the mix only where recommended or permitted by the manufacturer and Engineer. The quantity and gradation of the aggregate shall be in accordance with the manufacturer's recommendations.

Admixtures, if approved by the Department, shall be used in accordance with the manufacturer's recommendations. The manufacture date shall be clearly stamped on each container. Admixtures with an expired shelf life shall not be used.

The Engineer reserves the right to reject material based on unsatisfactory performance.

Initial setting time shall not be less than 10 minutes when tested in accordance with ASTM C266.

Test the expansion and shrinkage of the grout in accordance with ASTM C1090. The grout shall expand no more than 0.2% and shall exhibit no shrinkage. Furnish a Type 4 material certification showing results of tests conducted to determine the properties listed in the Standard Specifications and to assure the material is non-shrink.

Unless required elsewhere in the contract the compressive strength at 3 days shall be at least 5000 psi. Compressive strength in the laboratory shall be determined in accordance with ASTM C109 except the test mix shall contain only water and the dry manufactured material. Compressive strength in the field will be determined by molding and testing

C-25

4" x 8" cylinders in accordance with AASHTO T22. Construction loading and traffic loading shall not be allowed until the 3 day compressive strength is achieved.

When tested in accordance with ASTM C666, Procedure A, the durability factor of the grout shall not be less than 80.

3.0 SAMPLING AND PLACEMENT

Place and maintain components in final position until grout placement is complete and accepted. Concrete surfaces to receive grout shall be free of defective concrete, laitance, oil, grease and other foreign matter. Saturate concrete surfaces with clean water and remove excess water prior to placing grout.

Do not place grout if the grout temperature is less than 50°F or more than 90°F or if the air temperature measured at the location of the grouting operation in the shade away from artificial heat is below 45°F.

Provide grout at a rate that permits proper handling, placing and finishing in accordance with the manufacturer's recommendations unless directed otherwise by the Engineer. Use grout free of any lumps and undispersed cement. Agitate grout continuously before placement.

Control grout delivery so the interval between placing batches in the same component does not exceed 20 minutes.

The Engineer will determine the locations to sample grout and the number and type of samples collected for field and laboratory testing. The compressive strength of the grout will be considered the average compressive strength test results of 3 cube or 2 cylinder specimens at 28 days.

4.0 BASIS OF PAYMENT

No separate payment will be made for "Grout for Structures". The cost of the material, equipment, labor, placement, and any incidentals necessary to complete the work shall be considered incidental to the structure item requiring grout.

County : Alamance

| Line # | Item Number | Sec # | Description | Quantity | Unit Cost | Amount |
|----------------------|--------------|-------|--|---------------|-----------|--------|
| ROADWAY ITEMS | | | | | | |
| 0001 | 0000100000-N | 800 | MOBILIZATION | Lump Sum | L.S. | |
| 0002 | 0000400000-N | 801 | CONSTRUCTION SURVEYING | Lump Sum | L.S. | |
| 0003 | 0001000000-E | 200 | CLEARING & GRUBBING .. ACRE(S) | Lump Sum | L.S. | |
| 0004 | 0008000000-E | 200 | SUPPLEMENTARY CLEARING & GRUB- BING | 4 ACR | | |
| 0005 | 0015000000-N | 205 | SEALING ABANDONED WELLS | 31 EA | | |
| 0006 | 0022000000-E | 225 | UNCLASSIFIED EXCAVATION | 377,000 CY | | |
| 0007 | 0029000000-N | SP | REINFORCED BRIDGE APPROACH FILL, STATION ***** (26+55 -L-) | Lump Sum | L.S. | |
| 0008 | 0036000000-E | 225 | UNDERCUT EXCAVATION | 72,440 CY | | |
| 0009 | 0106000000-E | 230 | BORROW EXCAVATION | 688,000 CY | | |
| 0010 | 0134000000-E | 240 | DRAINAGE DITCH EXCAVATION | 41,800 CY | | |
| 0011 | 0141000000-E | 240 | BERM DITCH CONSTRUCTION | 1,150 LF | | |
| 0012 | 0156000000-E | 250 | REMOVAL OF EXISTING ASPHALT PAVEMENT | 47,950 SY | | |
| 0013 | 0192000000-N | 260 | PROOF ROLLING | 40 HR | | |
| 0014 | 0195000000-E | 265 | SELECT GRANULAR MATERIAL | 8,800 CY | | |
| 0015 | 0196000000-E | 270 | GEOTEXTILE FOR SOIL STABILIZA- TION | 69,100 SY | | |
| 0016 | 0199000000-E | SP | TEMPORARY SHORING | 2,200 SF | | |
| 0017 | 0220000000-E | SP | ROCK EMBANKMENTS | 1,400 TON | | |
| 0018 | 0222000000-E | SP | GEOTEXTILE FOR ROCK EMBANK- MENTS | 950 SY | | |
| 0019 | 0255000000-E | SP | GENERIC GRADING ITEM STOCKPILING CONTAMINATED SOIL | 100 TON | | |

County : Alamance

| Line # | Item Number | Sec # | Description | Quantity | Unit Cost | Amount |
|--------|--------------|-------|---|--------------|-----------|--------|
| 0020 | 0262000000-N | SP | GENERIC GRADING ITEM ENERGY DISSIPATOR BASIN | 1 EA | | |
| 0021 | 0314000000-E | SP | SELECT MATERIAL, CLASS ***** (VI) | 4,050 TON | | |
| 0022 | 0318000000-E | 300 | FOUNDATION CONDITIONING MATE- RIAL, MINOR STRUCTURES | 3,550 TON | | |
| 0023 | 0320000000-E | 300 | FOUNDATION CONDITIONING GEO- TEXTILE | 11,140 SY | | |
| 0024 | 0335200000-E | 305 | 15" DRAINAGE PIPE | 4,952 LF | | |
| 0025 | 0335300000-E | 305 | 18" DRAINAGE PIPE | 1,792 LF | | |
| 0026 | 0335400000-E | 305 | 24" DRAINAGE PIPE | 828 LF | | |
| 0027 | 0335500000-E | 305 | 30" DRAINAGE PIPE | 292 LF | | |
| 0028 | 0335600000-E | 305 | 36" DRAINAGE PIPE | 208 LF | | |
| 0029 | 0335700000-E | 305 | 42" DRAINAGE PIPE | 32 LF | | |
| 0030 | 0343000000-E | 310 | 15" SIDE DRAIN PIPE | 1,248 LF | | |
| 0031 | 0344000000-E | 310 | 18" SIDE DRAIN PIPE | 444 LF | | |
| 0032 | 0354000000-E | 310 | **** RC PIPE CULVERTS, CLASS ***** (30", V) | 332 LF | | |
| 0033 | 0366000000-E | 310 | 15" RC PIPE CULVERTS, CLASS III | 2,600 LF | | |
| 0034 | 0372000000-E | 310 | 18" RC PIPE CULVERTS, CLASS III | 936 LF | | |
| 0035 | 0378000000-E | 310 | 24" RC PIPE CULVERTS, CLASS III | 1,168 LF | | |
| 0036 | 0384000000-E | 310 | 30" RC PIPE CULVERTS, CLASS III | 1,000 LF | | |
| 0037 | 0390000000-E | 310 | 36" RC PIPE CULVERTS, CLASS III | 496 LF | | |

County : Alamance

| Line # | Item Number | Sec # | Description | Quantity | Unit Cost | Amount |
|--------|--------------|-------|---------------------------------------|----------|-----------|--------|
| 0038 | 0396000000-E | 310 | 42" RC PIPE CULVERTS, CLASS III | 704 | LF | |
| 0039 | 0402000000-E | 310 | 48" RC PIPE CULVERTS, CLASS III | 664 | LF | |
| 0040 | 0408000000-E | 310 | 54" RC PIPE CULVERTS, CLASS III | 444 | LF | |
| 0041 | 0414000000-E | 310 | 60" RC PIPE CULVERTS, CLASS III | 116 | LF | |
| 0042 | 0420000000-E | 310 | 66" RC PIPE CULVERTS, CLASS III | 192 | LF | |
| 0043 | 0426000000-E | 310 | 72" RC PIPE CULVERTS, CLASS III | 208 | LF | |
| 0044 | 0448000000-E | 310 | **** RC PIPE CULVERTS, CLASS IV (48") | 216 | LF | |
| 0045 | 0448000000-E | 310 | **** RC PIPE CULVERTS, CLASS IV (66") | 220 | LF | |
| 0046 | 0448200000-E | 310 | 15" RC PIPE CULVERTS, CLASS IV | 9,300 | LF | |
| 0047 | 0448300000-E | 310 | 18" RC PIPE CULVERTS, CLASS IV | 1,152 | LF | |
| 0048 | 0448400000-E | 310 | 24" RC PIPE CULVERTS, CLASS IV | 2,148 | LF | |
| 0049 | 0448500000-E | 310 | 30" RC PIPE CULVERTS, CLASS IV | 352 | LF | |
| 0050 | 0448600000-E | 310 | 36" RC PIPE CULVERTS, CLASS IV | 80 | LF | |
| 0051 | 0448700000-E | 310 | 42" RC PIPE CULVERTS, CLASS IV | 344 | LF | |
| 0052 | 0582000000-E | 310 | 15" CS PIPE CULVERTS, 0.064" THICK | 748 | LF | |
| 0053 | 0588000000-E | 310 | 18" CS PIPE CULVERTS, 0.064" THICK | 68 | LF | |
| 0054 | 0594000000-E | 310 | 24" CS PIPE CULVERTS, 0.064" THICK | 124 | LF | |

County : Alamance

| Line # | Item Number | Sec # | Description | Quantity | Unit Cost | Amount |
|--------|--------------|-------|---|---------------|-----------|--------|
| 0055 | 0636000000-E | 310 | *** CS PIPE ELBOWS, ***** THICK (15", 0.064") | 29 EA | | |
| 0056 | 0636000000-E | 310 | *** CS PIPE ELBOWS, ***** THICK (18", 0.064") | 3 EA | | |
| 0057 | 0636000000-E | 310 | *** CS PIPE ELBOWS, ***** THICK (24", 0.064") | 3 EA | | |
| 0058 | 0636000000-E | 310 | *** CS PIPE ELBOWS, ***** THICK (30", 0.079") | 1 EA | | |
| 0059 | 0995000000-E | 340 | PIPE REMOVAL | 5,351 LF | | |
| 0060 | 0996000000-N | 350 | PIPE CLEAN-OUT | 1 EA | | |
| 0061 | 1011000000-N | 500 | FINE GRADING | Lump Sum | L.S. | |
| 0062 | 1044000000-E | 501 | LIME TREATED SOIL (SLURRY METHOD) | 71,070 SY | | |
| 0063 | 1066000000-E | 501 | LIME FOR LIME TREATED SOIL | 720 TON | | |
| 0064 | 1099500000-E | 505 | SHALLOW UNDERCUT | 18,500 CY | | |
| 0065 | 1099700000-E | 505 | CLASS IV SUBGRADE STABILIZA- TION | 35,000 TON | | |
| 0066 | 1110000000-E | 510 | STABILIZER AGGREGATE | 500 TON | | |
| 0067 | 1115000000-E | SP | GEOTEXTILE FOR PAVEMENT STA- BILIZATION | 57,567 SY | | |
| 0068 | 1121000000-E | 520 | AGGREGATE BASE COURSE | 3,200 TON | | |
| 0069 | 1176000000-E | 542 | SOIL CEMENT BASE | 71,070 SY | | |
| 0070 | 1187000000-E | 542 | PORTLAND CEMENT FOR SOIL CE- MENT BASE | 1,955 TON | | |
| 0071 | 1198000000-E | 542 | AGGREGATE FOR SOIL CEMENT BASE | 1,960 TON | | |

County : Alamance

| Line # | Item Number | Sec # | Description | Quantity | Unit Cost | Amount |
|--------|--------------|-------|---|----------|-----------|--------|
| 0072 | 1209000000-E | 543 | ASPHALT CURING SEAL | 21,350 | | GAL |
| 0073 | 1220000000-E | 545 | INCIDENTAL STONE BASE | 1,000 | | TON |
| 0074 | 1275000000-E | 600 | PRIME COAT | 2,555 | | GAL |
| 0075 | 1297000000-E | 607 | MILLING ASPHALT PAVEMENT, **** DEPTH (1-1/2") | 19,790 | | SY |
| 0076 | 1297000000-E | 607 | MILLING ASPHALT PAVEMENT, **** DEPTH (3") | 1,480 | | SY |
| 0077 | 1330000000-E | 607 | INCIDENTAL MILLING | 4,260 | | SY |
| 0078 | 1489000000-E | 610 | ASPHALT CONC BASE COURSE, TYPE B25.0B | 25,050 | | TON |
| 0079 | 1491000000-E | 610 | ASPHALT CONC BASE COURSE, TYPE B25.0C | 29,400 | | TON |
| 0080 | 1498000000-E | 610 | ASPHALT CONC INTERMEDIATE COURSE, TYPE I19.0B | 21,870 | | TON |
| 0081 | 1503000000-E | 610 | ASPHALT CONC INTERMEDIATE COURSE, TYPE I19.0C | 35,700 | | TON |
| 0082 | 1519000000-E | 610 | ASPHALT CONC SURFACE COURSE, TYPE S9.5B | 17,600 | | TON |
| 0083 | 1523000000-E | 610 | ASPHALT CONC SURFACE COURSE, TYPE S9.5C | 27,600 | | TON |
| 0084 | 1524200000-E | 610 | ASPHALT CONC SURFACE COURSE, TYPE S9.5D | 1,090 | | TON |
| 0085 | 1575000000-E | 620 | ASPHALT BINDER FOR PLANT MIX | 7,845 | | TON |
| 0086 | 1577000000-E | 620 | POLYMER MODIFIED ASPHALT BIN- DER FOR PLANT MIX | 65 | | TON |
| 0087 | 1693000000-E | 654 | ASPHALT PLANT MIX, PAVEMENT REPAIR | 1,150 | | TON |
| 0088 | 1840000000-E | 665 | MILLED RUMBLE STRIPS (ASPHALT CONCRETE) | 2,430 | | LF |

County : Alamance

| Line # | Item Number | Sec # | Description | Quantity | Unit Cost | Amount |
|--------|--------------|-------|--|----------|-----------|--------|
| 0089 | 2022000000-E | 815 | SUBDRAIN EXCAVATION | 1,848 | CY | |
| 0090 | 2033000000-E | 815 | SUBDRAIN FINE AGGREGATE | 924 | CY | |
| 0091 | 2044000000-E | 815 | 6" PERFORATED SUBDRAIN PIPE | 5,500 | LF | |
| 0092 | 2070000000-N | 815 | SUBDRAIN PIPE OUTLET | 11 | EA | |
| 0093 | 2077000000-E | 815 | 6" OUTLET PIPE | 66 | LF | |
| 0094 | 2143000000-E | 818 | BLOTTING SAND | 10 | TON | |
| 0095 | 2209000000-E | 838 | ENDWALLS | 55.2 | CY | |
| 0096 | 2220000000-E | 838 | REINFORCED ENDWALLS | 36.9 | CY | |
| 0097 | 2253000000-E | 840 | PIPE COLLARS | 0.447 | CY | |
| 0098 | 2275000000-E | SP | FLOWABLE FILL | 6 | CY | |
| 0099 | 2286000000-N | 840 | MASONRY DRAINAGE STRUCTURES | 278 | EA | |
| 0100 | 2297000000-E | 840 | MASONRY DRAINAGE STRUCTURES | 3 | CY | |
| 0101 | 2308000000-E | 840 | MASONRY DRAINAGE STRUCTURES | 137.6 | LF | |
| 0102 | 2364000000-N | 840 | FRAME WITH TWO GRATES, STD 840.16 | 29 | EA | |
| 0103 | 2364200000-N | 840 | FRAME WITH TWO GRATES, STD 840.20 | 50 | EA | |
| 0104 | 2365000000-N | 840 | FRAME WITH TWO GRATES, STD 840.22 | 3 | EA | |
| 0105 | 2366000000-N | 840 | FRAME WITH TWO GRATES, STD 840.24 | 64 | EA | |
| 0106 | 2367000000-N | 840 | FRAME WITH TWO GRATES, STD 840.29 | 22 | EA | |
| 0107 | 2374000000-N | 840 | FRAME WITH GRATE & HOOD, STD 840.03, TYPE ** (E) | 18 | EA | |

County : Alamance

| Line # | Item Number | Sec # | Description | Quantity | Unit Cost | Amount |
|--------|--------------|-------|--|--------------|-----------|--------|
| 0108 | 2374000000-N | 840 | FRAME WITH GRATE & HOOD, STD 840.03, TYPE ** (F) | 37 EA | | |
| 0109 | 2374000000-N | 840 | FRAME WITH GRATE & HOOD, STD 840.03, TYPE ** (G) | 39 EA | | |
| 0110 | 2396000000-N | 840 | FRAME WITH COVER, STD 840.54 | 17 EA | | |
| 0111 | 2440000000-N | 852 | CONCRETE TRANSITIONAL SECTION FOR CATCH BASIN | 1 EA | | |
| 0112 | 2451000000-N | 852 | CONCRETE TRANSITIONAL SECTION FOR DROP INLET | 18 EA | | |
| 0113 | 2462000000-E | SP | *** SLUICE GATE (15") | 1 EA | | |
| 0114 | 2462000000-E | SP | *** SLUICE GATE (18") | 2 EA | | |
| 0115 | 2462000000-E | SP | *** SLUICE GATE (30") | 1 EA | | |
| 0116 | 2538000000-E | 846 | ***-*** CONCRETE CURB & GUTTER (2'-9") | 8,650 LF | | |
| 0117 | 2542000000-E | 846 | 1'-6" CONCRETE CURB & GUTTER | 15,730 LF | | |
| 0118 | 2549000000-E | 846 | 2'-6" CONCRETE CURB & GUTTER | 18,400 LF | | |
| 0119 | 2556000000-E | 846 | SHOULDER BERM GUTTER | 4,590 LF | | |
| 0120 | 2591000000-E | 848 | 4" CONCRETE SIDEWALK | 6,650 SY | | |
| 0121 | 2605000000-N | 848 | CONCRETE CURB RAMP | 60 EA | | |
| 0122 | 2612000000-E | 848 | 6" CONCRETE DRIVEWAY | 210 SY | | |
| 0123 | 2619000000-E | 850 | 4" CONCRETE PAVED DITCH | 84 SY | | |
| 0124 | 2655000000-E | 852 | 5" MONOLITHIC CONCRETE ISLANDS (KEYED IN) | 7,580 SY | | |

County : Alamance

| Line # | Item Number | Sec # | Description | Quantity | Unit Cost | Amount |
|--------|--------------|-------|---|--------------|-----------|--------|
| 0125 | 2710000000-N | 854 | CONCRETE BARRIER TRANSITION SECTION | 1 EA | | |
| 0126 | 2724000000-E | 857 | PRECAST REINFORCED CONCRETE BARRIER, SINGLE FACED | 88 LF | | |
| 0127 | 2752000000-E | SP | GENERIC PAVING ITEM MEDIAN HAZARD PROTECTION | 108 LF | | |
| 0128 | 3000000000-N | SP | IMPACT ATTENUATOR UNIT, TYPE 350 | 2 EA | | |
| 0129 | 3030000000-E | 862 | STEEL BM GUARDRAIL | 13,100 LF | | |
| 0130 | 3105000000-N | 862 | STEEL BM GUARDRAIL TERMINAL SECTIONS | 6 EA | | |
| 0131 | 3150000000-N | 862 | ADDITIONAL GUARDRAIL POSTS | 50 EA | | |
| 0132 | 3210000000-N | 862 | GUARDRAIL ANCHOR UNITS, TYPE CAT-1 | 21 EA | | |
| 0133 | 3215000000-N | 862 | GUARDRAIL ANCHOR UNITS, TYPE III | 4 EA | | |
| 0134 | 3270000000-N | SP | GUARDRAIL ANCHOR UNITS, TYPE 350 | 30 EA | | |
| 0135 | 3285000000-N | SP | GUARDRAIL ANCHOR UNITS, TYPE M-350 | 2 EA | | |
| 0136 | 3317000000-N | 862 | GUARDRAIL ANCHOR UNITS, TYPE B-77 | 14 EA | | |
| 0137 | 3360000000-E | 863 | REMOVE EXISTING GUARDRAIL | 563 LF | | |
| 0138 | 3380000000-E | 862 | TEMPORARY STEEL BM GUARDRAIL | 487.5 LF | | |
| 0139 | 3389100000-N | SP | TEMPORARY GUARDRAIL ANCHOR UNITS, TYPE 350 | 2 EA | | |
| 0140 | 3500000000-E | 866 | WOVEN WIRE FENCE, *** FABRIC (48") | 37,000 LF | | |
| 0141 | 3509000000-E | 866 | 4" TIMBER FENCE POSTS, 7'-6" LONG | 2,289 EA | | |

County : Alamance

| Line # | Item Number | Sec # | Description | Quantity | Unit Cost | Amount |
|--------|--------------|-------|---|--------------|-----------|--------|
| 0142 | 3515000000-E | 866 | 5" TIMBER FENCE POSTS, 8'-0" LONG | 646 EA | | |
| 0143 | 3536000000-E | 866 | CHAIN LINK FENCE, 48" FABRIC | 450 LF | | |
| 0144 | 3542000000-E | 866 | METAL LINE POSTS FOR 48" CHAIN LINK FENCE | 38 EA | | |
| 0145 | 3548000000-E | 866 | METAL TERMINAL POSTS FOR 48" CHAIN LINK FENCE | 9 EA | | |
| 0146 | 3557000000-E | 866 | ADDITIONAL BARBED WIRE | 200 LF | | |
| 0147 | 3564000000-E | 866 | SINGLE GATES, *** HIGH, *** WIDE, *** OPENING (48", 12', 12') | 2 EA | | |
| 0148 | 3564000000-E | 866 | SINGLE GATES, *** HIGH, *** WIDE, *** OPENING (48", 20', 20') | 2 EA | | |
| 0149 | 3628000000-E | 876 | RIP RAP, CLASS I | 890 TON | | |
| 0150 | 3635000000-E | 876 | RIP RAP, CLASS II | 25 TON | | |
| 0151 | 3649000000-E | 876 | RIP RAP, CLASS B | 2,430 TON | | |
| 0152 | 3656000000-E | 876 | GEOTEXTILE FOR DRAINAGE | 12,350 SY | | |
| 0153 | 3659000000-N | SP | PREFORMED SCOUR HOLES WITH LEVEL SPREADER APRON | 2 EA | | |
| 0154 | 4054000000-E | 902 | PLAIN CONCRETE SIGN FOUNDATIONS | 1 CY | | |
| 0155 | 4057000000-E | SP | OVERHEAD FOOTING | 73 CY | | |
| 0156 | 4060000000-E | 903 | SUPPORTS, BREAKAWAY STEEL BEAM | 1,294 LB | | |
| 0157 | 4072000000-E | 903 | SUPPORTS, 3-LB STEEL U-CHANNEL | 2,753 LF | | |
| 0158 | 4082100000-N | SP | SUPPORTS, OVERHEAD SIGN STRUCTURE AT STA ***** (16+50 -RPC-) | Lump Sum | L.S. | |

County : Alamance

| Line # | Item Number | Sec # | Description | Quantity | Unit Cost | Amount |
|--------|--------------|-------|---|-------------|-----------|--------|
| 0159 | 4082100000-N | SP | SUPPORTS, OVERHEAD SIGN STRUCTURE AT STA ***** (21+15 -L-) | Lump Sum | L.S. | |
| 0160 | 4082100000-N | SP | SUPPORTS, OVERHEAD SIGN STRUCTURE AT STA ***** (25+44 -L-) | Lump Sum | L.S. | |
| 0161 | 4082100000-N | SP | SUPPORTS, OVERHEAD SIGN STRUCTURE AT STA ***** (28+17 -L-) | Lump Sum | L.S. | |
| 0162 | 4082100000-N | SP | SUPPORTS, OVERHEAD SIGN STRUCTURE AT STA ***** (32+38 -L-) | Lump Sum | L.S. | |
| 0163 | 4082100000-N | SP | SUPPORTS, OVERHEAD SIGN STRUCTURE AT STA ***** (46+00 -L-) | Lump Sum | L.S. | |
| 0164 | 4096000000-N | 904 | SIGN ERECTION, TYPE D | 4 EA | | |
| 0165 | 4102000000-N | 904 | SIGN ERECTION, TYPE E | 107 EA | | |
| 0166 | 4108000000-N | 904 | SIGN ERECTION, TYPE F | 42 EA | | |
| 0167 | 4110000000-N | 904 | SIGN ERECTION, TYPE *** (GROUND MOUNTED) (A) | 2 EA | | |
| 0168 | 4116100000-N | 904 | SIGN ERECTION, RELOCATE, TYPE **** (GROUND MOUNTED) (A) | 3 EA | | |
| 0169 | 4138000000-N | 907 | DISPOSAL OF SUPPORT, STEEL BEAM | 3 EA | | |
| 0170 | 4152000000-N | 907 | DISPOSAL OF SIGN SYSTEM, STEEL BEAM | 2 EA | | |
| 0171 | 4155000000-N | 907 | DISPOSAL OF SIGN SYSTEM, U-CHANNEL | 45 EA | | |
| 0172 | 4400000000-E | 1110 | WORK ZONE SIGNS (STATIONARY) | 2,376 SF | | |
| 0173 | 4405000000-E | 1110 | WORK ZONE SIGNS (PORTABLE) | 429 SF | | |
| 0174 | 4410000000-E | 1110 | WORK ZONE SIGNS (BARRICADE MOUNTED) | 474 SF | | |

County : Alamance

| Line # | Item Number | Sec # | Description | Quantity | Unit Cost | Amount |
|--------|--------------|-------|--|----------|-----------|--------|
| 0175 | 4415000000-N | 1115 | FLASHING ARROW BOARD | 4 | EA | |
| 0176 | 4420000000-N | 1120 | PORTABLE CHANGEABLE MESSAGE SIGN | 6 | EA | |
| 0177 | 4422000000-N | 1120 | PORTABLE CHANGEABLE MESSAGE SIGN (SHORT TERM) | 84 | DAY | |
| 0178 | 4430000000-N | 1130 | DRUMS | 1,050 | EA | |
| 0179 | 4435000000-N | 1135 | CONES | 70 | EA | |
| 0180 | 4445000000-E | 1145 | BARRICADES (TYPE III) | 512 | LF | |
| 0181 | 4450000000-N | 1150 | FLAGGER | 80 | HR | |
| 0182 | 4455000000-N | 1150 | FLAGGER | 240 | DAY | |
| 0183 | 4465000000-N | 1160 | TEMPORARY CRASH CUSHIONS | 10 | EA | |
| 0184 | 4470000000-N | 1160 | RESET TEMPORARY CRASH CUSHION | 6 | EA | |
| 0185 | 4480000000-N | 1165 | TMA | 2 | EA | |
| 0186 | 4485000000-E | 1170 | PORTABLE CONCRETE BARRIER | 4,200 | LF | |
| 0187 | 4490000000-E | 1170 | PORTABLE CONCRETE BARRIER (ANCHORED) | 200 | LF | |
| 0188 | 4500000000-E | 1170 | RESET PORTABLE CONCRETE BARRIER | 1,800 | LF | |
| 0189 | 4520000000-N | 1266 | TUBULAR MARKERS (FIXED) | 13 | EA | |
| 0190 | 4590000000-E | SP | GENERIC TRAFFIC CONTROL ITEM WORK ZONE "PERFORMANCE" PAVEMENT MARKING LINES (6") | 7,800 | LF | |
| 0191 | 4595000000-E | SP | GENERIC TRAFFIC CONTROL ITEM WORK ZONE TRAFFIC "PATTERN MASKING" | 437,000 | SF | |
| 0192 | 4600000000-N | SP | GENERIC TRAFFIC CONTROL ITEM SEQUENTIAL FLASHING WARNING LIGHTS | 24 | EA | |

County : Alamance

| Line # | Item Number | Sec # | Description | Quantity | Unit Cost | Amount |
|--------|--------------|-------|--|----------|-----------|--------|
| 0193 | 4650000000-N | 1251 | TEMPORARY RAISED PAVEMENT MARKERS | 831 | EA | |
| 0194 | 4685000000-E | 1205 | THERMOPLASTIC PAVEMENT MARKING LINES (4", 90 MILS) | 83,000 | LF | |
| 0195 | 4686000000-E | 1205 | THERMOPLASTIC PAVEMENT MARKING LINES (4", 120 MILS) | 67,850 | LF | |
| 0196 | 4688000000-E | 1205 | THERMOPLASTIC PAVEMENT MARKING LINES (6", 90 MILS) | 5,000 | LF | |
| 0197 | 4690000000-E | 1205 | THERMOPLASTIC PAVEMENT MARKING LINES (6", 120 MILS) | 2,150 | LF | |
| 0198 | 4695000000-E | 1205 | THERMOPLASTIC PAVEMENT MARKING LINES (8", 90 MILS) | 7,500 | LF | |
| 0199 | 4697000000-E | 1205 | THERMOPLASTIC PAVEMENT MARKING LINES (8", 120 MILS) | 4,000 | LF | |
| 0200 | 4700000000-E | 1205 | THERMOPLASTIC PAVEMENT MARKING LINES (12", 90 MILS) | 17,000 | LF | |
| 0201 | 4710000000-E | 1205 | THERMOPLASTIC PAVEMENT MARKING LINES (24", 120 MILS) | 2,600 | LF | |
| 0202 | 4721000000-E | 1205 | THERMOPLASTIC PAVEMENT MARKING CHARACTER (120 MILS) | 32 | EA | |
| 0203 | 4725000000-E | 1205 | THERMOPLASTIC PAVEMENT MARKING SYMBOL (90 MILS) | 300 | EA | |
| 0204 | 4770000000-E | 1205 | COLD APPLIED PLASTIC PAVEMENT MARKING LINES, TYPE ** (4") (II) | 3,501 | LF | |
| 0205 | 4770000000-E | 1205 | COLD APPLIED PLASTIC PAVEMENT MARKING LINES, TYPE ** (4") (IV) | 1,175 | LF | |
| 0206 | 4780000000-E | 1205 | COLD APPLIED PLASTIC PAVEMENT MARKING LINES, TYPE ** (8") (II) | 30 | LF | |
| 0207 | 4805000000-N | 1205 | COLD APPLIED PLASTIC PAVEMENT MARKING SYMBOL, TYPE ** (II) | 9 | EA | |

County : Alamance

| Line # | Item Number | Sec # | Description | Quantity | Unit Cost | Amount |
|--------|--------------|-------|--|----------|-----------|--------|
| 0208 | 4810000000-E | 1205 | PAINT PAVEMENT MARKING LINES (4") | 601,688 | LF | |
| 0209 | 4815000000-E | 1205 | PAINT PAVEMENT MARKING LINES (6") | 13,200 | LF | |
| 0210 | 4820000000-E | 1205 | PAINT PAVEMENT MARKING LINES (8") | 9,510 | LF | |
| 0211 | 4825000000-E | 1205 | PAINT PAVEMENT MARKING LINES (12") | 9,400 | LF | |
| 0212 | 4835000000-E | 1205 | PAINT PAVEMENT MARKING LINES (24") | 7,980 | LF | |
| 0213 | 4840000000-N | 1205 | PAINT PAVEMENT MARKING CHARACTER | 20 | EA | |
| 0214 | 4845000000-N | 1205 | PAINT PAVEMENT MARKING SYMBOL | 457 | EA | |
| 0215 | 4850000000-E | 1205 | REMOVAL OF PAVEMENT MARKING LINES (4") | 21,000 | LF | |
| 0216 | 4855000000-E | 1205 | REMOVAL OF PAVEMENT MARKING LINES (6") | 6,975 | LF | |
| 0217 | 4860000000-E | 1205 | REMOVAL OF PAVEMENT MARKING LINES (8") | 900 | LF | |
| 0218 | 4870000000-E | 1205 | REMOVAL OF PAVEMENT MARKING LINES (24") | 200 | LF | |
| 0219 | 4875000000-N | 1205 | REMOVAL OF PAVEMENT MARKING SYMBOLS & CHARACTERS | 23 | EA | |
| 0220 | 4900000000-N | 1251 | PERMANENT RAISED PAVEMENT MARKERS | 1,390 | EA | |
| 0221 | 4905000000-N | 1253 | SNOWPLOWABLE PAVEMENT MARKERS | 84 | EA | |
| 0222 | 5255000000-N | 1413 | PORTABLE LIGHTING | Lump Sum | L.S. | |
| 0223 | 5546000000-E | 1515 | 8" VALVE | 5 | EA | |
| 0224 | 5589200000-E | 1515 | 2" AIR RELEASE VALVE | 2 | EA | |

County : Alamance

| Line # | Item Number | Sec # | Description | Quantity | Unit Cost | Amount |
|--------|--------------|-------|---|----------|-----------|--------|
| 0225 | 5709400000-E | 1520 | 8" FORCE MAIN SEWER | 2,799 | LF | |
| 0226 | 5769000000-E | SP | DUCTILE IRON SEWER PIPE FITTINGS | 440 | LB | |
| 0227 | 5801000000-E | 1530 | ABANDON 8" UTILITY PIPE | 2,745 | LF | |
| 0228 | 5871500000-E | 1550 | TRENCHLESS INSTALLATION OF 8" IN SOIL | 245 | LF | |
| 0229 | 5871510000-E | 1550 | TRENCHLESS INSTALLATION OF 8" NOT IN SOIL | 245 | LF | |
| 0230 | 6000000000-E | 1605 | TEMPORARY SILT FENCE | 120,000 | LF | |
| 0231 | 6006000000-E | 1610 | STONE FOR EROSION CONTROL, CLASS A | 3,080 | TON | |
| 0232 | 6009000000-E | 1610 | STONE FOR EROSION CONTROL, CLASS B | 11,500 | TON | |
| 0233 | 6012000000-E | 1610 | SEDIMENT CONTROL STONE | 27,500 | TON | |
| 0234 | 6015000000-E | 1615 | TEMPORARY MULCHING | 148 | ACR | |
| 0235 | 6018000000-E | 1620 | SEED FOR TEMPORARY SEEDING | 7,200 | LB | |
| 0236 | 6021000000-E | 1620 | FERTILIZER FOR TEMPORARY SEEDING | 38 | TON | |
| 0237 | 6024000000-E | 1622 | TEMPORARY SLOPE DRAINS | 6,200 | LF | |
| 0238 | 6029000000-E | SP | SAFETY FENCE | 4,400 | LF | |
| 0239 | 6030000000-E | 1630 | SILT EXCAVATION | 110,000 | CY | |
| 0240 | 6036000000-E | 1631 | MATTING FOR EROSION CONTROL | 140,000 | SY | |
| 0241 | 6037000000-E | SP | COIR FIBER MAT | 565 | SY | |
| 0242 | 6038000000-E | SP | PERMANENT SOIL REINFORCEMENT MAT | 13,220 | SY | |
| 0243 | 6042000000-E | 1632 | 1/4" HARDWARE CLOTH | 16,620 | LF | |

County : Alamance

| Line # | Item Number | Sec # | Description | Quantity | Unit Cost | Amount |
|--------|--------------|-------|---------------------------------------|----------|-----------|--------|
| 0244 | 6045000000-E | SP | *** TEMPORARY PIPE (18") | 160 | | LF |
| 0245 | 6046000000-E | 1636 | TEMPORARY PIPE FOR STREAM CROSSING | 300 | | LF |
| 0246 | 6048000000-E | SP | FLOATING TURBIDITY CURTAIN | 520 | | SY |
| 0247 | 6069000000-E | 1638 | STILLING BASINS | 750 | | CY |
| 0248 | 6070000000-N | 1639 | SPECIAL STILLING BASINS | 4 | | EA |
| 0249 | 6071012000-E | SP | COIR FIBER WATTLE | 10,800 | | LF |
| 0250 | 6071020000-E | SP | POLYACRYLAMIDE (PAM) | 8,100 | | LB |
| 0251 | 6071030000-E | 1640 | COIR FIBER BAFFLE | 9,825 | | LF |
| 0252 | 6071050000-E | SP | *** SKIMMER (1-1/2") | 33 | | EA |
| 0253 | 6071050000-E | SP | *** SKIMMER (2") | 11 | | EA |
| 0254 | 6071050000-E | SP | *** SKIMMER (2-1/2") | 2 | | EA |
| 0255 | 6071050000-E | SP | *** SKIMMER (3") | 1 | | EA |
| 0256 | 6084000000-E | 1660 | SEEDING & MULCHING | 102 | | ACR |
| 0257 | 6087000000-E | 1660 | MOWING | 90 | | ACR |
| 0258 | 6090000000-E | 1661 | SEED FOR REPAIR SEEDING | 1,500 | | LB |
| 0259 | 6093000000-E | 1661 | FERTILIZER FOR REPAIR SEEDING | 3.75 | | TON |
| 0260 | 6096000000-E | 1662 | SEED FOR SUPPLEMENTAL SEEDING | 2,325 | | LB |
| 0261 | 6108000000-E | 1665 | FERTILIZER TOPDRESSING | 70 | | TON |
| 0262 | 6111000000-E | SP | IMPERVIOUS DIKE | 400 | | LF |

County : Alamance

| Line # | Item Number | Sec # | Description | Quantity | Unit Cost | Amount |
|--------|--------------|-------|--|----------|-----------|--------|
| 0263 | 6114500000-N | 1667 | SPECIALIZED HAND MOWING | 500 | MHR | |
| 0264 | 6117000000-N | SP | RESPONSE FOR EROSION CONTROL | 100 | EA | |
| 0265 | 6120000000-E | SP | CULVERT DIVERSION CHANNEL | 1,350 | CY | |
| 0266 | 6123000000-E | 1670 | REFORESTATION | 5 | ACR | |
| 0267 | 6126000000-E | SP | STREAMBANK REFORESTATION | 0.32 | ACR | |
| 0268 | 6132000000-N | SP | GENERIC EROSION CONTROL ITEM CONCRETE WASHOUT STRUCTURE | 16 | EA | |
| 0269 | 7048500000-E | 1705 | PEDESTRIAN SIGNAL HEAD (16", 1 SECTION W/COUNTDOWN) | 34 | EA | |
| 0270 | 7060000000-E | 1705 | SIGNAL CABLE | 23,925 | LF | |
| 0271 | 7120000000-E | 1705 | VEHICLE SIGNAL HEAD (12", 3 SECTION) | 123 | EA | |
| 0272 | 7132000000-E | 1705 | VEHICLE SIGNAL HEAD (12", 4 SECTION) | 10 | EA | |
| 0273 | 7144000000-E | 1705 | VEHICLE SIGNAL HEAD (12", 5 SECTION) | 11 | EA | |
| 0274 | 7252000000-E | 1710 | MESSENGER CABLE (1/4") | 10,455 | LF | |
| 0275 | 7279000000-E | 1715 | TRACER WIRE | 3,800 | LF | |
| 0276 | 7300000000-E | 1715 | UNPAVED TRENCHING (***** (1, 2")) | 8,910 | LF | |
| 0277 | 7300100000-E | 1715 | UNPAVED TRENCHING FOR TEMP- ORARY LEAD-IN | 1,965 | LF | |
| 0278 | 7301000000-E | 1715 | DIRECTIONAL DRILL (***** (1, 2")) | 425 | LF | |
| 0279 | 7301000000-E | 1715 | DIRECTIONAL DRILL (***** (2, 2")) | 175 | LF | |
| 0280 | 7324000000-N | 1716 | JUNCTION BOX (STANDARD SIZE) | 92 | EA | |

County : Alamance

| Line # | Item Number | Sec # | Description | Quantity | Unit Cost | Amount |
|--------|--------------|-------|--|--------------|-----------|--------|
| 0281 | 7348000000-N | 1716 | JUNCTION BOX (OVER-SIZED, HEAVY DUTY) | 21 EA | | |
| 0282 | 7360000000-N | 1720 | WOOD POLE | 15 EA | | |
| 0283 | 7372000000-N | 1721 | GUY ASSEMBLY | 36 EA | | |
| 0284 | 7408000000-E | 1722 | 1" RISER WITH WEATHERHEAD | 4 EA | | |
| 0285 | 7420000000-E | 1722 | 2" RISER WITH WEATHERHEAD | 12 EA | | |
| 0286 | 7432000000-E | 1722 | 2" RISER WITH HEAT SHRINK TUBING | 10 EA | | |
| 0287 | 7444000000-E | 1725 | INDUCTIVE LOOP SAWCUT | 15,125 LF | | |
| 0288 | 7456000000-E | 1726 | LEAD-IN CABLE (*****)(14-2) | 43,725 LF | | |
| 0289 | 7481000000-N | SP | SITE SURVEY | 2 EA | | |
| 0290 | 7481220000-N | SP | CAMERA WITH INTERNAL LOOP EMULATOR PROCESSING UNIT | 4 EA | | |
| 0291 | 7481280000-N | SP | RELOCATE CAMERA SENSOR UNIT | 2 EA | | |
| 0292 | 7516000000-E | 1730 | COMMUNICATIONS CABLE (**FIBER) (12) | 3,500 LF | | |
| 0293 | 7516000000-E | 1730 | COMMUNICATIONS CABLE (**FIBER) (24) | 5,800 LF | | |
| 0294 | 7540000000-N | 1731 | SPLICE ENCLOSURE | 5 EA | | |
| 0295 | 7552000000-N | 1731 | INTERCONNECT CENTER | 7 EA | | |
| 0296 | 7564000000-N | 1732 | FIBER-OPTIC TRANSCEIVER, DROP & REPEAT | 7 EA | | |
| 0297 | 7566000000-N | 1733 | DELINEATOR MARKER | 13 EA | | |
| 0298 | 7575142000-N | 1736 | 900MHZ RADIO | 3 EA | | |
| 0299 | 7575160000-E | 1734 | REMOVE EXISTING COMMUNICATIONS CABLE | 1,200 LF | | |

County : Alamance

| Line # | Item Number | Sec # | Description | Quantity | Unit Cost | Amount |
|--------|--------------|-------|--|----------|-----------|--------|
| 0300 | 7576000000-N | SP | METAL STRAIN SIGNAL POLE | 32 | EA | |
| 0301 | 7588000000-N | SP | METAL POLE WITH SINGLE MAST ARM | 2 | EA | |
| 0302 | 7590000000-N | SP | METAL POLE WITH DUAL MAST ARM | 2 | EA | |
| 0303 | 7613000000-N | SP | SOIL TEST | 36 | EA | |
| 0304 | 7614100000-E | SP | DRILLED PIER FOUNDATION | 216 | CY | |
| 0305 | 7631000000-N | SP | MAST ARM WITH METAL POLE DE-SIGN | 4 | EA | |
| 0306 | 7636000000-N | 1745 | SIGN FOR SIGNALS | 38 | EA | |
| 0307 | 7642100000-N | 1743 | TYPE I POST WITH FOUNDATION | 2 | EA | |
| 0308 | 7642200000-N | 1743 | TYPE II PEDESTAL WITH FOUNDATION | 28 | EA | |
| 0309 | 7684000000-N | 1750 | SIGNAL CABINET FOUNDATION | 10 | EA | |
| 0310 | 7756000000-N | 1751 | CONTROLLER WITH CABINET (TYPE 2070L, BASE MOUNTED) | 10 | EA | |
| 0311 | 7768000000-N | 1751 | CONTROLLER WITH CABINET (TYPE 2070L, POLE MOUNTED) | 2 | EA | |
| 0312 | 7780000000-N | 1751 | DETECTOR CARD (TYPE 2070L) | 69 | EA | |
| 0313 | 7901000000-N | 1753 | CABINET BASE EXTENDER | 10 | EA | |
| 0314 | 7980000000-N | SP | GENERIC SIGNAL ITEM MICROWAVE VEHICLE DETECTOR - SINGLE ZONE | 2 | EA | |

CULVERT ITEMS

| | | | | | | |
|------|--------------|-----|--|----------|------|--|
| 0315 | 8035000000-N | 402 | REMOVAL OF EXISTING STRUCTURE AT STATION ***** (19+77.00-Y10-) | Lump Sum | L.S. | |
|------|--------------|-----|--|----------|------|--|

County : Alamance

| Line # | Item Number | Sec # | Description | Quantity | Unit Cost | Amount |
|--------|--------------|-------|--|---------------|-----------|--------|
| 0316 | 8126000000-N | 414 | CULVERT EXCAVATION, STA ***** (179+55.00-L-) | Lump Sum | L.S. | |
| 0317 | 8126000000-N | 414 | CULVERT EXCAVATION, STA ***** (19+77.00-Y10-) | Lump Sum | L.S. | |
| 0318 | 8126000000-N | 414 | CULVERT EXCAVATION, STA ***** (96+88.00 -L-) | Lump Sum | L.S. | |
| 0319 | 8133000000-E | 414 | FOUNDATION CONDITIONING MATERIAL, BOX CULVERT | 888 TON | | |
| 0320 | 8196000000-E | 420 | CLASS A CONCRETE (CULVERT) | 1,200.6 CY | | |
| 0321 | 8245000000-E | 425 | REINFORCING STEEL (CULVERT) | 142,445 LB | | |

WALL ITEMS

| | | | | | | |
|------|--------------|----|-----------------------------------|-------------|--|--|
| 0322 | 8801000000-E | SP | MSE RETAINING WALL NO **** (1) | 3,449 SF | | |
| 0323 | 8801000000-E | SP | MSE RETAINING WALL NO **** (2) | 4,617 SF | | |
| 0324 | 8802030000-E | SP | SEGMENTAL GRAVITY RETAINING WALLS | 263 SF | | |

STRUCTURE ITEMS

| | | | | | | |
|------|--------------|-----|--|----------|------|--|
| 0325 | 8091000000-N | 410 | FOUNDATION EXCAVATION FOR BENT ** AT STATION ***** (1,146+61.35-L-NBL) | Lump Sum | L.S. | |
| 0326 | 8091000000-N | 410 | FOUNDATION EXCAVATION FOR BENT ** AT STATION ***** (1,146+61.35-L-SBL) | Lump Sum | L.S. | |
| 0327 | 8091000000-N | 410 | FOUNDATION EXCAVATION FOR BENT ** AT STATION ***** (2,146+61.35-L-NBL) | Lump Sum | L.S. | |

County : Alamance

| Line # | Item Number | Sec # | Description | Quantity | Unit Cost | Amount |
|--------|--------------|-------|--|---------------|-----------|--------|
| 0328 | 8091000000-N | 410 | FOUNDATION EXCAVATION FOR BENT ** AT STATION ***** (2,146+61.35-L-SBL) | Lump Sum | L.S. | |
| 0329 | 8091000000-N | 410 | FOUNDATION EXCAVATION FOR BENT ** AT STATION ***** (3,146+61.35-L-NBL) | Lump Sum | L.S. | |
| 0330 | 8091000000-N | 410 | FOUNDATION EXCAVATION FOR BENT ** AT STATION ***** (3,146+61.35-L-SBL) | Lump Sum | L.S. | |
| 0331 | 8105560000-E | 411 | 4'-0" DIA DRILLED PIERS IN SOIL | 70.3 LF | | |
| 0332 | 8105660000-E | 411 | 4'-0" DIA DRILLED PIERS NOT IN SOIL | 31 LF | | |
| 0333 | 8112730000-N | 450 | PDA TESTING | 1 EA | | |
| 0334 | 8113000000-N | 411 | SID INSPECTIONS | 3 EA | | |
| 0335 | 8114000000-N | 411 | SPT TESTING | 3 EA | | |
| 0336 | 8115000000-N | 411 | CSL TESTING | 1 EA | | |
| 0337 | 8147000000-E | 420 | REINFORCED CONCRETE DECK SLAB | 46,347 SF | | |
| 0338 | 8161000000-E | 420 | GROOVING BRIDGE FLOORS | 42,545 SF | | |
| 0339 | 8182000000-E | 420 | CLASS A CONCRETE (BRIDGE) | 871.6 CY | | |
| 0340 | 8210000000-N | 422 | BRIDGE APPROACH SLABS, STATION ***** (146+61.35-L-NBL) | Lump Sum | L.S. | |
| 0341 | 8210000000-N | 422 | BRIDGE APPROACH SLABS, STATION ***** (146+61.35-L-SBL) | Lump Sum | L.S. | |
| 0342 | 8210000000-N | 422 | BRIDGE APPROACH SLABS, STATION ***** (26+54.73-NBL-) | Lump Sum | L.S. | |
| 0343 | 8217000000-E | 425 | REINFORCING STEEL (BRIDGE) | 143,844 LB | | |
| 0344 | 8238000000-E | 425 | SPIRAL COLUMN REINFORCING STEEL (BRIDGE) | 14,778 LB | | |

County : Alamance

| Line # | Item Number | Sec # | Description | Quantity | Unit Cost | Amount |
|--------|--------------|-------|--|----------|-----------|--------|
| 0345 | 8277000000-E | 430 | MODIFIED 72" PRESTRESSED CONC GIRDERS | 3,901.13 | LF | |
| 0346 | 8280000000-E | 440 | APPROX LBS STRUCTURAL STEEL | 446,250 | LS | |
| 0347 | 8328200000-E | SP | PILE DRIVING EQUIPMENT SETUP FOR *** STEEL PILES (HP 12 X 53) | 132 | EA | |
| 0348 | 8364000000-E | 450 | HP12X53 STEEL PILES | 8,200 | LF | |
| 0349 | 8475000000-E | 460 | TWO BAR METAL RAIL | 472.38 | LF | |
| 0350 | 8503000000-E | 460 | CONCRETE BARRIER RAIL | 2,050.4 | LF | |
| 0351 | 8517000000-E | 460 | 1'-***X ***** CONCRETE PARA-PET (1'-2" X 2'-6") | 243.69 | LF | |
| 0352 | 8517000000-E | 460 | 1'-***X ***** CONCRETE PARA-PET (1'-2" X 3'-0 1/2") | 243.69 | LF | |
| 0353 | 8531000000-E | 462 | 4" SLOPE PROTECTION | 905 | SY | |
| 0354 | 8657000000-N | 430 | ELASTOMERIC BEARINGS | Lump Sum | L.S. | |
| 0355 | 8706000000-N | SP | EXPANSION JOINT SEALS | Lump Sum | L.S. | |
| 0356 | 8727000000-N | SP | ELECTRICAL CONDUIT SYSTEM FOR SIGNALS AT STA***** (146+61.35-L- NBL) | Lump Sum | L.S. | |
| 0357 | 8867000000-E | SP | GENERIC STRUCTURE ITEM TWO BAR METAL RAIL RETROFIT | 426.69 | LF | |

GFE

MBE GOAL SET: 4.00%

MBE GOAL OBT: 7.58%

WBE GOAL SET: 5.00%

WBE GOAL OBT: 0.83%

Vendor 1 of 10: THALLE CONSTRUCTION CO., INC. (3424)
Call Order 005 (Proposal: C203844)

Bid Information

Proposal County: ALAMANCE**Vendor Address:** 900 NC Highway 86 North
Hillsborough , North Carolina , 27278**Signature Check:** Stephen_Kohler_3424**Time Bid Received:** May 16, 2017 01:51 PM**Amendment Count:** 1**Bid Checksum:** 4D6CE8E0**Bid Total:** \$45,389,069.36**Items Total:** \$45,389,069.36**Time Total:** \$0.00**Bidding Errors:**

DBE Warning : WBE Warning: WBE Commitment Goal not met

DBE Error : WBE Entry #3 is incomplete

DBE Warning : DBEName Carolina Transport not chosen fr

Vendor 1 of 10: THALLE CONSTRUCTION CO., INC. (3424)
Call Order 005 (Proposal: C203844)

Bid Bond Information

| | |
|-----------------------------|--|
| Projects: | Bond Maximum: |
| Counties: | State of Incorporation: |
| Bond ID: SNC17344470 | Agency Execution Date: 5/8/2017 2 |
| Paid by Check: No | Surety Name: surety2000 |
| Bond Percent: 5% | Bond Agency Name: Federal Insurance Company |

Bidder 1 of 10

Vendor 3424's Bid Information for Call 005, Letting L170516, 05/16/17

Thalle Construction Company (3424)
Call Order 005 (Proposal ID C203844)

LIST OF MBE PARTICIPANTS

| VENDOR NUMBER | DBE NAME ADDRESS | WORK CODE TYPE OF WORK | CERT TYPE AMOUNT | |
|---------------|--|------------------------|-----------------------|-----------|
| MB 11572 | CRUZ BROTHERS CONCRETE, INC. 1572 PAYNE ROAD/LOT 75 LOT 75 , GRAHAM, NC 27253 | | Sub 1,397,866.00 | COMMITTED |
| MB 6715 | F-T TRUCKING LLC 6034 OLD ORCHARD ROAD , KERNERSVILLE, NC 27284 | | Sub 2,041,296.00 | COMMITTED |
| | | | TOTAL: \$3,439,162.00 | |
| | | | 7.58% | |

Vendor 3424's Bid Information for Call 005, Letting L170516, 05/16/17

Thalle Construction Company (3424)
Call Order 005 (Proposal ID C203844)

LIST OF WBE PARTICIPANTS

| VENDOR NUMBER | DBE NAME ADDRESS | WORK CODE TYPE OF WORK | CERT TYPE AMOUNT | |
|---------------|--|------------------------|-----------------------|-----------|
| WB 3376 | REYNOLDS FENCE & GUARDRAIL INC 9320 MACHADO DRIVE , INDIAN TRAIL, NC 28079 | | Sub 349,031.25 | COMMITTED |
| 4753 | STATE CONSTRUCTION CO. P O BOX 26415 , CHARLOTTE, NC 28221 Carolina Transport of Greensbor | | Sub 904,347.50 | |
| | | | Sub 387,806.70 | |
| WB 3230 | HIATT & MASON ENTERPRISES INC POST OFFICE BOX 1378 , MOUNT AIRY, NC 27030 | | Sub 27,330.36 | COMMITTED |
| | | | TOTAL: \$1,280,709.11 | |
| | | | 2.82% | |

Vendor 3424's Bid Information for Call 005, Letting L170516, 05/16/17

Thalle Construction Company (3424)
Call Order 005 (Proposal ID C203844)

Miscellaneous Data Info - Contractor Responses:

=====

NON-COLLUSION AND DEBARMENT CERTIFICATION

Explanation of the prospective bidder that is unable to certify to any of the statements in this certification:

Explanation:
NOT ANSWERED
NOT ANSWERED
NOT ANSWERED
NOT ANSWERED

AWARD LIMITS ON MULTIPLE PROJECTS

By answering YES to this statement, the bidder acknowledges that they are using

Bidder 5 of 10

By answering YES to this statement, the bidder acknowledges that they are using the award limits on multiple projects. No

It is the desire of the Bidder to be awarded contracts, the value of which will not exceed a total of NOT ANSWERED for those projects indicated herein, for which bids will be opened on (MM/DD/YY)

The Award Limits shall apply to the following projects:

| Contract Number | County |
|-----------------|--------|
| NOT ANSWERED | |
| NOT ANSWERED | |
| NOT ANSWERED | |
| NOT ANSWERED | |
| NOT ANSWERED | |
| NOT ANSWERED | |

Bid Bond Data Info - Contractor Responses:

=====

BondID: SNC17895613
 Surety Registry Agency: surety2000
 Verified?: Yes
 Surety Agency: Travelers Casualty and Surety Company of America
 Bond Execution Date: 5/1/2017 2
 Bond Amount: \$2,499,839.57 (Five Percent of Bid)

Contract ID: C203844 Project(s): STATE FUNDED
 Letting Date: 05-16-17 Call Order: 005
 Bidder: 3424 - Thalle Construction Company

| Line No. | Item Description | Approx. Quantity and Units | Unit Price Dollars Cts | Bid Amount Dollars Ct |
|----------------------------|---|----------------------------|--------------------------|-------------------------|
| Section 0001 ROADWAY ITEMS | | | | |
| Alt Group | | | | |
| 0001 | 0000100000-N MOBILIZATION | LUMP | LUMP | 2,200,000.00 |
| 0002 | 0000400000-N CONSTRUCTION SURVEYING | LUMP | LUMP | 350,000.00 |
| 0003 | 0001000000-E CLEARING & GRUBBING .. ACRE(S) | LUMP | LUMP | 1,025,000.00 |
| 0004 | 0008000000-E SUPPLEMENTARY CLEARING & GRUBBING | 4.000 ACR | 12,000.00000 | 48,000.00 |
| 0005 | 0015000000-N SEALING ABANDONED WELLS | 31.000 EA | 1,750.00000 | 54,250.00 |
| 0006 | 0022000000-E UNCLASSIFIED EXCAVATION | 377,000.000 CY | 6.00000 | 2,262,000.00 |
| 0007 | 0029000000-N REINFORCED BRIDGE APPROACH FILL, STATION ***** (26+55 -L-) | LUMP | LUMP | 17,533.13 |
| 0008 | 0036000000-E UNDERCUT EXCAVATION | 72,440.000 CY | 5.10000 | 369,444.00 |
| 0009 | 0106000000-E BORROW EXCAVATION | 688,000.000 CY | 0.01000 | 6,880.00 |
| 0010 | 0134000000-E DRAINAGE DITCH EXCAVATION | 41,800.000 CY | 4.50000 | 188,100.00 |

Contract ID: C203844

Project(s): STATE FUNDED

Letting Date: 05-16-17 Call Order: 005

Bidder: 3424 - Thalle Construction Company

| Line No. | Item Description | Approx. Quantity and Units | Unit Price Dollars Cts | Bid Amount Dollars Ct |
|----------|---|----------------------------|--------------------------|-------------------------|
| 0011 | 0141000000-E BERM DITCH CONSTRUCTION | 1,150.000 LF | 9.00000 | 10,350.00 |
| 0012 | 0156000000-E REMOVAL OF EXISTING ASPHALT PAVEMENT | 47,950.000 SY | 1.50000 | 71,925.00 |
| 0013 | 0192000000-N PROOF ROLLING | 40.000 HR | 600.00000 | 24,000.00 |
| 0014 | 0195000000-E SELECT GRANULAR MATERIAL | 8,800.000 CY | 43.00000 | 378,400.00 |
| 0015 | 0196000000-E GEOTEXTILE FOR SOIL STABILIZATION | 69,100.000 SY | 2.00000 | 138,200.00 |
| 0016 | 0199000000-E TEMPORARY SHORING | 2,200.000 SF | 50.00000 | 110,000.00 |
| 0017 | 0220000000-E ROCK EMBANKMENTS | 1,400.000 TON | 40.00000 | 56,000.00 |
| 0018 | 0222000000-E GEOTEXTILE FOR ROCK EMBANKMENTS | 950.000 SY | 2.00000 | 1,900.00 |
| 0019 | 0255000000-E GENERIC GRADING ITEM STOCKPILING CONTAMINATED SOIL | 100.000 TON | 23.00000 | 2,300.00 |
| 0020 | 0262000000-N GENERIC GRADING ITEM ENERGY DISSIPATOR BASIN | 1.000 EA | 2,600.00000 | 2,600.00 |
| 0021 | 0314000000-E SELECT MATERIAL, CLASS ***** (VI) | 4,050.000 TON | 30.00000 | 121,500.00 |
| 0022 | 0318000000-E FOUNDATION CONDITIONING MATERIAL, MINOR STRUCTURES | 3,550.000 TON | 33.00000 | 117,150.00 |

(Contains bid errors)

Check: 4D6CE8E0 Page 2

Contract ID: C203844

Project(s): STATE FUNDED

Letting Date: 05-16-17 Call Order: 005

Bidder: 3424 - Thalle Construction Company

| Line No. | Item Description | Approx. Quantity and Units | Unit Price Dollars Cts | Bid Amount Dollars Ct |
|----------|--|----------------------------|--------------------------|-------------------------|
| 0023 | 0320000000-E FOUNDATION CONDITIONING GEO- TEXTILE | 11,140.000 SY | 1.50000 | 16,710.00 |
| 0024 | 0335200000-E 15" DRAINAGE PIPE | 4,952.000 LF | 45.00000 | 222,840.00 |
| 0025 | 0335300000-E 18" DRAINAGE PIPE | 1,792.000 LF | 50.00000 | 89,600.00 |
| 0026 | 0335400000-E 24" DRAINAGE PIPE | 828.000 LF | 65.00000 | 53,820.00 |
| 0027 | 0335500000-E 30" DRAINAGE PIPE | 292.000 LF | 100.00000 | 29,200.00 |
| 0028 | 0335600000-E 36" DRAINAGE PIPE | 208.000 LF | 125.00000 | 26,000.00 |
| 0029 | 0335700000-E 42" DRAINAGE PIPE | 32.000 LF | 160.00000 | 5,120.00 |
| 0030 | 0343000000-E 15" SIDE DRAIN PIPE | 1,248.000 LF | 42.00000 | 52,416.00 |
| 0031 | 0344000000-E 18" SIDE DRAIN PIPE | 444.000 LF | 52.00000 | 23,088.00 |
| 0032 | 0354000000-E ***" RC PIPE CULVERTS, CLASS ***** (30", V) | 332.000 LF | 115.00000 | 38,180.00 |
| 0033 | 0366000000-E 15" RC PIPE CULVERTS, CLASS III | 2,600.000 LF | 105.00000 | 273,000.00 |
| 0034 | 0372000000-E 18" RC PIPE CULVERTS, CLASS III | 936.000 LF | 95.00000 | 88,920.00 |

(Contains bid errors)

Check: 4D6CE8E0 Page 3

Contract ID: C203844

Project(s): STATE FUNDED

Letting Date: 05-16-17 Call Order: 005

Bidder: 3424 - Thalle Construction Company

| Line No. | Item Description | Approx. Quantity and Units | Unit Price Dollars Cts | Bid Amount Dollars Ct |
|----------|--|----------------------------|--------------------------|-------------------------|
| 0035 | 0378000000-E 24" RC PIPE CULVERTS, CLASS III | 1,168.000 | 75.00000 | 87,600.00 |
| | | LF | | |
| 0036 | 0384000000-E 30" RC PIPE CULVERTS, CLASS III | 1,000.000 | 92.00000 | 92,000.00 |
| | | LF | | |
| 0037 | 0390000000-E 36" RC PIPE CULVERTS, CLASS III | 496.000 | 126.00000 | 62,496.00 |
| | | LF | | |
| 0038 | 0396000000-E 42" RC PIPE CULVERTS, CLASS III | 704.000 | 155.00000 | 109,120.00 |
| | | LF | | |
| 0039 | 0402000000-E 48" RC PIPE CULVERTS, CLASS III | 664.000 | 180.00000 | 119,520.00 |
| | | LF | | |
| 0040 | 0408000000-E 54" RC PIPE CULVERTS, CLASS III | 444.000 | 240.00000 | 106,560.00 |
| | | LF | | |
| 0041 | 0414000000-E 60" RC PIPE CULVERTS, CLASS III | 116.000 | 290.00000 | 33,640.00 |
| | | LF | | |
| 0042 | 0420000000-E 66" RC PIPE CULVERTS, CLASS III | 192.000 | 365.00000 | 70,080.00 |
| | | LF | | |
| 0043 | 0426000000-E 72" RC PIPE CULVERTS, CLASS III | 208.000 | 450.00000 | 93,600.00 |
| | | LF | | |
| 0044 | 0448000000-E ****" RC PIPE CULVERTS, CLASS IV | 216.000 | 230.00000 | 49,680.00 |
| | (48") | LF | | |
| 0045 | 0448000000-E ****" RC PIPE CULVERTS, CLASS IV | 220.000 | 450.00000 | 99,000.00 |
| | (66") | LF | | |
| 0046 | 0448200000-E 15" RC PIPE CULVERTS, CLASS IV | 9,300.000 | 53.00000 | 492,900.00 |
| | | LF | | |

(Contains bid errors)

Check: 4D6CE8E0 Page 4

Contract ID: C203844

Project(s): STATE FUNDED

Letting Date: 05-16-17 Call Order: 005

Bidder: 3424 - Thalle Construction Company

| Line No. | Item Description | Approx. Quantity and Units | Unit Price | | Bid Amount | |
|----------|--|----------------------------|-------------|-----|------------|----|
| | | | Dollars | Cts | Dollars | Ct |
| 0047 | 0448300000-E 18" RC PIPE CULVERTS, CLASS IV | 1,152.000 | 55.00000 | | 63,360.00 | |
| | | LF | | | | |
| 0048 | 0448400000-E 24" RC PIPE CULVERTS, CLASS IV | 2,148.000 | 80.00000 | | 171,840.00 | |
| | | LF | | | | |
| 0049 | 0448500000-E 30" RC PIPE CULVERTS, CLASS IV | 352.000 | 100.00000 | | 35,200.00 | |
| | | LF | | | | |
| 0050 | 0448600000-E 36" RC PIPE CULVERTS, CLASS IV | 80.000 | 136.00000 | | 10,880.00 | |
| | | LF | | | | |
| 0051 | 0448700000-E 42" RC PIPE CULVERTS, CLASS IV | 344.000 | 170.00000 | | 58,480.00 | |
| | | LF | | | | |
| 0052 | 0582000000-E 15" CS PIPE CULVERTS, 0.064" THICK | 748.000 | 53.00000 | | 39,644.00 | |
| | | LF | | | | |
| 0053 | 0588000000-E 18" CS PIPE CULVERTS, 0.064" THICK | 68.000 | 65.00000 | | 4,420.00 | |
| | | LF | | | | |
| 0054 | 0594000000-E 24" CS PIPE CULVERTS, 0.064" THICK | 124.000 | 75.00000 | | 9,300.00 | |
| | | LF | | | | |
| 0055 | 0636000000-E **" CS PIPE ELBOWS, ***** THICK | 29.000 | 700.00000 | | 20,300.00 | |
| | (15", 0.064") | EA | | | | |
| 0056 | 0636000000-E **" CS PIPE ELBOWS, ***** THICK | 3.000 | 800.00000 | | 2,400.00 | |
| | (18", 0.064") | EA | | | | |
| 0057 | 0636000000-E **" CS PIPE ELBOWS, ***** THICK | 3.000 | 1,000.00000 | | 3,000.00 | |
| | (24", 0.064") | EA | | | | |
| 0058 | 0636000000-E **" CS PIPE ELBOWS, ***** THICK | 1.000 | 1,300.00000 | | 1,300.00 | |
| | (30", 0.079") | EA | | | | |

(Contains bid errors)

Check: 4D6CE8E0 Page 5

Contract ID: C203844

Project(s): STATE FUNDED

Letting Date: 05-16-17 Call Order: 005

Bidder: 3424 - Thalle Construction Company

| Line No. | Item Description | Approx. Quantity and Units | Unit Price Dollars Cts | Bid Amount Dollars Ct |
|----------|--|----------------------------|--------------------------|-------------------------|
| 0059 | 0995000000-E PIPE REMOVAL | 5,351.000 LF | 22.00000 | 117,722.00 |
| 0060 | 0996000000-N PIPE CLEAN-OUT | 1.000 EA | 6,000.00000 | 6,000.00 |
| 0061 | 1011000000-N FINE GRADING | LUMP | LUMP | 1,200,000.00 |
| 0062 | 1044000000-E LIME TREATED SOIL (SLURRY METHOD) | 71,070.000 SY | 2.30000 | 163,461.00 |
| 0063 | 1066000000-E LIME FOR LIME TREATED SOIL | 720.000 TON | 165.00000 | 118,800.00 |
| 0064 | 1099500000-E SHALLOW UNDERCUT | 18,500.000 CY | 7.00000 | 129,500.00 |
| 0065 | 1099700000-E CLASS IV SUBGRADE STABILIZATION | 35,000.000 TON | 36.00000 | 1,260,000.00 |
| 0066 | 1110000000-E STABILIZER AGGREGATE | 500.000 TON | 36.00000 | 18,000.00 |
| 0067 | 1115000000-E GEOTEXTILE FOR PAVEMENT STABILIZATION | 57,567.000 SY | 5.00000 | 287,835.00 |
| 0068 | 1121000000-E AGGREGATE BASE COURSE | 3,200.000 TON | 35.00000 | 112,000.00 |
| 0069 | 1176000000-E SOIL CEMENT BASE | 71,070.000 SY | 2.20000 | 156,354.00 |
| 0070 | 1187000000-E PORTLAND CEMENT FOR SOIL CEMENT BASE | 1,955.000 TON | 170.00000 | 332,350.00 |

(Contains bid errors)

Check: 4D6CE8E0 Page 6

Contract ID: C203844

Project(s): STATE FUNDED

Letting Date: 05-16-17 Call Order: 005

Bidder: 3424 - Thalle Construction Company

| Line No. | Item Description | Approx. Quantity and Units | Unit Price Dollars Cts | Bid Amount Dollars Ct |
|----------|--|----------------------------|--------------------------|-------------------------|
| 0071 | 1198000000-E AGGREGATE FOR SOIL CEMENT BASE | 1,960.000 TON | 35.00000 | 68,600.00 |
| 0072 | 1209000000-E ASPHALT CURING SEAL | 21,350.000 GAL | 3.20000 | 68,320.00 |
| 0073 | 1220000000-E INCIDENTAL STONE BASE | 1,000.000 TON | 25.00000 | 25,000.00 |
| 0074 | 1275000000-E PRIME COAT | 2,555.000 GAL | 3.50000 | 8,942.50 |
| 0075 | 1297000000-E MILLING ASPHALT PAVEMENT, ***"DEPTH (1-1/2") | 19,790.000 SY | 2.75000 | 54,422.50 |
| 0076 | 1297000000-E MILLING ASPHALT PAVEMENT, ***"DEPTH (3") | 1,480.000 SY | 2.75000 | 4,070.00 |
| 0077 | 1330000000-E INCIDENTAL MILLING | 4,260.000 SY | 8.00000 | 34,080.00 |
| 0078 | 1489000000-E ASPHALT CONC BASE COURSE, TYPE B25.0B | 25,050.000 TON | 48.00000 | 1,202,400.00 |
| 0079 | 1491000000-E ASPHALT CONC BASE COURSE, TYPE B25.0C | 29,400.000 TON | 46.00000 | 1,352,400.00 |
| 0080 | 1498000000-E ASPHALT CONC INTERMEDIATE COURSE, TYPE I19.0B | 21,870.000 TON | 49.00000 | 1,071,630.00 |
| 0081 | 1503000000-E ASPHALT CONC INTERMEDIATE COURSE, TYPE I19.0C | 35,700.000 TON | 47.00000 | 1,677,900.00 |
| 0082 | 1519000000-E ASPHALT CONC SURFACE COURSE, TYPE S9.5B | 17,600.000 TON | 51.00000 | 897,600.00 |

(Contains bid errors)

Check: 4D6CE8E0 Page 7

Contract ID: C203844

Project(s): STATE FUNDED

Letting Date: 05-16-17 Call Order: 005

Bidder: 3424 - Thalle Construction Company

| Line No. | Item Description | Approx. Quantity and Units | Unit Price Dollars Cts | Bid Amount Dollars Ct |
|----------|--|----------------------------|--------------------------|-------------------------|
| 0083 | 1523000000-E ASPHALT CONC SURFACE COURSE, TYPE S9.5C | 27,600.000 TON | 53.00000 | 1,462,800.00 |
| 0084 | 1524200000-E ASPHALT CONC SURFACE COURSE, TYPE S9.5D | 1,090.000 TON | 70.00000 | 76,300.00 |
| 0085 | 1575000000-E ASPHALT BINDER FOR PLANT MIX | 7,845.000 TON | 425.00000 | 3,334,125.00 |
| 0086 | 1577000000-E POLYMER MODIFIED ASPHALT BIN- DER FOR PLANT MIX | 65.000 TON | 650.00000 | 42,250.00 |
| 0087 | 1693000000-E ASPHALT PLANT MIX, PAVEMENT REPAIR | 1,150.000 TON | 165.00000 | 189,750.00 |
| 0088 | 1840000000-E MILLED RUMBLE STRIPS (ASPHALT CONCRETE) | 2,430.000 LF | 2.64000 | 6,415.20 |
| 0089 | 2022000000-E SUBDRAIN EXCAVATION | 1,848.000 CY | 25.00000 | 46,200.00 |
| 0090 | 2033000000-E SUBDRAIN FINE AGGREGATE | 924.000 CY | 55.00000 | 50,820.00 |
| 0091 | 2044000000-E 6" PERFORATED SUBDRAIN PIPE | 5,500.000 LF | 14.00000 | 77,000.00 |
| 0092 | 2070000000-N SUBDRAIN PIPE OUTLET | 11.000 EA | 350.00000 | 3,850.00 |
| 0093 | 2077000000-E 6" OUTLET PIPE | 66.000 LF | 40.00000 | 2,640.00 |
| 0094 | 2143000000-E BLOTTING SAND | 10.000 TON | 65.00000 | 650.00 |

(Contains bid errors)

Check: 4D6CE8E0 Page 8

Contract ID: C203844

Project(s): STATE FUNDED

Letting Date: 05-16-17 Call Order: 005

Bidder: 3424 - Thalle Construction Company

| Line No. | Item Description | Approx. Quantity and Units | Unit Price Dollars Cts | Bid Amount Dollars Ct |
|----------|--|----------------------------|--------------------------|-------------------------|
| 0095 | 2209000000-E ENDWALLS | 55.200 CY | 1,300.00000 | 71,760.00 |
| 0096 | 2220000000-E REINFORCED ENDWALLS | 36.900 CY | 2,400.00000 | 88,560.00 |
| 0097 | 2253000000-E PIPE COLLARS | 0.447 CY | 1,300.00000 | 581.10 |
| 0098 | 2275000000-E FLOWABLE FILL | 6.000 CY | 300.00000 | 1,800.00 |
| 0099 | 2286000000-N MASONRY DRAINAGE STRUCTURES | 278.000 EA | 3,000.00000 | 834,000.00 |
| 0100 | 2297000000-E MASONRY DRAINAGE STRUCTURES | 3.000 CY | 1,200.00000 | 3,600.00 |
| 0101 | 2308000000-E MASONRY DRAINAGE STRUCTURES | 137.600 LF | 610.00000 | 83,936.00 |
| 0102 | 2364000000-N FRAME WITH TWO GRATES, STD 840.16 | 29.000 EA | 850.00000 | 24,650.00 |
| 0103 | 2364200000-N FRAME WITH TWO GRATES, STD 840.20 | 50.000 EA | 775.00000 | 38,750.00 |
| 0104 | 2365000000-N FRAME WITH TWO GRATES, STD 840.22 | 3.000 EA | 775.00000 | 2,325.00 |
| 0105 | 2366000000-N FRAME WITH TWO GRATES, STD 840.24 | 64.000 EA | 775.00000 | 49,600.00 |
| 0106 | 2367000000-N FRAME WITH TWO GRATES, STD 840.29 | 22.000 EA | 775.00000 | 17,050.00 |

(Contains bid errors)

Check: 4D6CE8E0 Page 9

Contract ID: C203844

Project(s): STATE FUNDED

Letting Date: 05-16-17 Call Order: 005

Bidder: 3424 - Thalle Construction Company

| Line No. | Item Description | Approx. Quantity and Units | Unit Price Dollars Cts | Bid Amount Dollars Ct |
|----------|---|----------------------------|--------------------------|-------------------------|
| 0107 | 2374000000-N FRAME WITH GRATE & HOOD, STD 840.03, TYPE ** (E) | 18.000 EA | 920.00000 | 16,560.00 |
| 0108 | 2374000000-N FRAME WITH GRATE & HOOD, STD 840.03, TYPE ** (F) | 37.000 EA | 920.00000 | 34,040.00 |
| 0109 | 2374000000-N FRAME WITH GRATE & HOOD, STD 840.03, TYPE ** (G) | 39.000 EA | 920.00000 | 35,880.00 |
| 0110 | 2396000000-N FRAME WITH COVER, STD 840.54 | 17.000 EA | 685.00000 | 11,645.00 |
| 0111 | 2440000000-N CONCRETE TRANSITIONAL SECTION FOR CATCH BASIN | 1.000 EA | 685.00000 | 685.00 |
| 0112 | 2451000000-N CONCRETE TRANSITIONAL SECTION FOR DROP INLET | 18.000 EA | 685.00000 | 12,330.00 |
| 0113 | 2462000000-E *** SLUICE GATE (15") | 1.000 EA | 4,000.00000 | 4,000.00 |
| 0114 | 2462000000-E *** SLUICE GATE (18") | 2.000 EA | 4,100.00000 | 8,200.00 |
| 0115 | 2462000000-E *** SLUICE GATE (30") | 1.000 EA | 5,000.00000 | 5,000.00 |
| 0116 | 2538000000-E ***'-*** CONCRETE CURB & GUTTER (2'-9") | 8,650.000 LF | 15.75000 | 136,237.50 |
| 0117 | 2542000000-E 1'-6" CONCRETE CURB & GUTTER | 15,730.000 LF | 12.75000 | 200,557.50 |
| 0118 | 2549000000-E 2'-6" CONCRETE CURB & GUTTER | 18,400.000 LF | 15.50000 | 285,200.00 |

(Contains bid errors)

Check: 4D6CE8E0 Page 10

Contract ID: C203844

Project(s): STATE FUNDED

Letting Date: 05-16-17 Call Order: 005

Bidder: 3424 - Thalle Construction Company

| Line No. | Item Description | Approx. Quantity and Units | Unit Price Dollars Cts | Bid Amount Dollars Ct |
|----------|--|----------------------------|--------------------------|-------------------------|
| 0119 | 2556000000-E SHOULDER BERM GUTTER | 4,590.000 LF | 15.75000 | 72,292.50 |
| 0120 | 2591000000-E 4" CONCRETE SIDEWALK | 6,650.000 SY | 27.25000 | 181,212.50 |
| 0121 | 2605000000-N CONCRETE CURB RAMP | 60.000 EA | 1,550.00000 | 93,000.00 |
| 0122 | 2612000000-E 6" CONCRETE DRIVEWAY | 210.000 SY | 47.50000 | 9,975.00 |
| 0123 | 2619000000-E 4" CONCRETE PAVED DITCH | 84.000 SY | 70.25000 | 5,901.00 |
| 0124 | 2655000000-E 5" MONOLITHIC CONCRETE ISLANDS (KEYED IN) | 7,580.000 SY | 51.25000 | 388,475.00 |
| 0125 | 2710000000-N CONCRETE BARRIER TRANSITION SECTION | 1.000 EA | 12,000.00000 | 12,000.00 |
| 0126 | 2724000000-E PRECAST REINFORCED CONCRETE BARRIER, SINGLE FACED | 88.000 LF | 135.00000 | 11,880.00 |
| 0127 | 2752000000-E GENERIC PAVING ITEM MEDIAN HAZARD PROTECTION | 108.000 LF | 175.00000 | 18,900.00 |
| 0128 | 3000000000-N IMPACT ATTENUATOR UNIT, TYPE 350 | 2.000 EA | 16,000.00000 | 32,000.00 |
| 0129 | 3030000000-E STEEL BM GUARDRAIL | 13,100.000 LF | 15.70000 | 205,670.00 |
| 0130 | 3105000000-N STEEL BM GUARDRAIL TERMINAL SECTIONS | 6.000 EA | 175.00000 | 1,050.00 |

(Contains bid errors)

Check: 4D6CE8E0 Page 11

Contract ID: C203844

Project(s): STATE FUNDED

Letting Date: 05-16-17 Call Order: 005

Bidder: 3424 - Thalle Construction Company

| Line No. | Item Description | Approx. Quantity and Units | Unit Price Dollars Cts | Bid Amount Dollars Ct |
|----------|---|----------------------------|--------------------------|-------------------------|
| 0131 | 3150000000-N ADDITIONAL GUARDRAIL POSTS | 50.000 EA | 25.00000 | 1,250.00 |
| 0132 | 3210000000-N GUARDRAIL ANCHOR UNITS, TYPE CAT-1 | 21.000 EA | 575.00000 | 12,075.00 |
| 0133 | 3215000000-N GUARDRAIL ANCHOR UNITS, TYPE III | 4.000 EA | 1,500.00000 | 6,000.00 |
| 0134 | 3270000000-N GUARDRAIL ANCHOR UNITS, TYPE 350 | 30.000 EA | 1,875.00000 | 56,250.00 |
| 0135 | 3285000000-N GUARDRAIL ANCHOR UNITS, TYPE M-350 | 2.000 EA | 1,975.00000 | 3,950.00 |
| 0136 | 3317000000-N GUARDRAIL ANCHOR UNITS, TYPE B-77 | 14.000 EA | 1,580.00000 | 22,120.00 |
| 0137 | 3360000000-E REMOVE EXISTING GUARDRAIL | 563.000 LF | 1.25000 | 703.75 |
| 0138 | 3380000000-E TEMPORARY STEEL BM GUARDRAIL | 487.500 LF | 11.00000 | 5,362.50 |
| 0139 | 3389100000-N TEMPORARY GUARDRAIL ANCHOR UNITS, TYPE 350 | 2.000 EA | 1,300.00000 | 2,600.00 |
| 0140 | 3500000000-E WOVEN WIRE FENCE, *** FABRIC (48") | 37,000.000 LF | 2.40000 | 88,800.00 |
| 0141 | 3509000000-E 4" TIMBER FENCE POSTS, 7'-6" LONG | 2,289.000 EA | 16.00000 | 36,624.00 |
| 0142 | 3515000000-E 5" TIMBER FENCE POSTS, 8'-0" LONG | 646.000 EA | 34.00000 | 21,964.00 |

(Contains bid errors)

Check: 4D6CE8E0 Page 12

Contract ID: C203844

Project(s): STATE FUNDED

Letting Date: 05-16-17 Call Order: 005

Bidder: 3424 - Thalle Construction Company

| Line No. | Item Description | Approx. Quantity and Units | Unit Price | | Bid Amount | |
|----------|--|----------------------------|-------------|-----|------------|----|
| | | | Dollars | Cts | Dollars | Ct |
| 0143 | 3536000000-E CHAIN LINK FENCE, 48" FABRIC | 450.000 | 8.00000 | | 3,600.00 | |
| | | LF | | | | |
| 0144 | 3542000000-E METAL LINE POSTS FOR 48" CHAINLINK FENCE | 38.000 | 30.00000 | | 1,140.00 | |
| | | EA | | | | |
| 0145 | 3548000000-E METAL TERMINAL POSTS FOR 48" CHAIN LINK FENCE | 9.000 | 60.00000 | | 540.00 | |
| | | EA | | | | |
| 0146 | 3557000000-E ADDITIONAL BARBED WIRE | 200.000 | 0.25000 | | 50.00 | |
| | | LF | | | | |
| 0147 | 3564000000-E SINGLE GATES, **" HIGH, **' WIDE, **' OPENING (48", 12', 12') | 2.000 | 500.00000 | | 1,000.00 | |
| | | EA | | | | |
| 0148 | 3564000000-E SINGLE GATES, **" HIGH, **' WIDE, **' OPENING (48", 20', 20') | 2.000 | 2,000.00000 | | 4,000.00 | |
| | | EA | | | | |
| 0149 | 3628000000-E RIP RAP, CLASS I | 890.000 | 55.00000 | | 48,950.00 | |
| | | TON | | | | |
| 0150 | 3635000000-E RIP RAP, CLASS II | 25.000 | 65.00000 | | 1,625.00 | |
| | | TON | | | | |
| 0151 | 3649000000-E RIP RAP, CLASS B | 2,430.000 | 50.00000 | | 121,500.00 | |
| | | TON | | | | |
| 0152 | 3656000000-E GEOTEXTILE FOR DRAINAGE | 12,350.000 | 3.01000 | | 37,173.50 | |
| | | SY | | | | |
| 0153 | 3659000000-N PREFORMED SCOUR HOLES WITH LEVEL SPREADER APRON | 2.000 | 1,100.00000 | | 2,200.00 | |
| | | EA | | | | |

Contract ID: C203844

Project(s): STATE FUNDED

Letting Date: 05-16-17 Call Order: 005

Bidder: 3424 - Thalle Construction Company

| Line No. | Item Description | Approx. Quantity and Units | Unit Price Dollars Cts | Bid Amount Dollars Ct |
|----------|--|----------------------------|--------------------------|-------------------------|
| 0154 | 4054000000-E PLAIN CONCRETE SIGN FOUNDATIONS | 1.000 CY | 835.00000 | 835.00 |
| 0155 | 4057000000-E OVERHEAD FOOTING | 73.000 CY | 1,110.00000 | 81,030.00 |
| 0156 | 4060000000-E SUPPORTS, BREAKAWAY STEEL BEAM | 1,294.000 LB | 6.40000 | 8,281.60 |
| 0157 | 4072000000-E SUPPORTS, 3-LB STEEL U-CHANNEL | 2,753.000 LF | 5.15000 | 14,177.95 |
| 0158 | 4082100000-N SUPPORTS, OVERHEAD SIGN STRUC-TURE AT STA ***** (16+50 -RPC-) | LUMP | LUMP | 53,410.00 |
| 0159 | 4082100000-N SUPPORTS, OVERHEAD SIGN STRUC-TURE AT STA ***** (21+15 -L-) | LUMP | LUMP | 56,835.00 |
| 0160 | 4082100000-N SUPPORTS, OVERHEAD SIGN STRUC-TURE AT STA ***** (25+44 -L-) | LUMP | LUMP | 22,190.00 |
| 0161 | 4082100000-N SUPPORTS, OVERHEAD SIGN STRUC-TURE AT STA ***** (28+17 -L-) | LUMP | LUMP | 22,705.00 |
| 0162 | 4082100000-N SUPPORTS, OVERHEAD SIGN STRUC-TURE AT STA ***** (32+38 -L-) | LUMP | LUMP | 46,170.00 |
| 0163 | 4082100000-N SUPPORTS, OVERHEAD SIGN STRUC-TURE AT STA ***** (46+00 -L-) | LUMP | LUMP | 21,780.00 |
| 0164 | 4096000000-N SIGN ERECTION, TYPE D | 4.000 EA | 115.00000 | 460.00 |

Contract ID: C203844

Project(s): STATE FUNDED

Letting Date: 05-16-17 Call Order: 005

Bidder: 3424 - Thalle Construction Company

| Line No. | Item Description | Approx. Quantity and Units | Unit Price Dollars Cts | Bid Amount Dollars Ct |
|----------|---|----------------------------|--------------------------|-------------------------|
| 0165 | 4102000000-N SIGN ERECTION, TYPE E | 107.000 EA | 55.00000 | 5,885.00 |
| 0166 | 4108000000-N SIGN ERECTION, TYPE F | 42.000 EA | 170.00000 | 7,140.00 |
| 0167 | 4110000000-N SIGN ERECTION, TYPE *** (GROUND MOUNTED) (A) | 2.000 EA | 510.00000 | 1,020.00 |
| 0168 | 4116100000-N SIGN ERECTION, RELOCATE, TYPE ***** (GROUND MOUNTED) (A) | 3.000 EA | 680.00000 | 2,040.00 |
| 0169 | 4138000000-N DISPOSAL OF SUPPORT, STEEL BEAM | 3.000 EA | 560.00000 | 1,680.00 |
| 0170 | 4152000000-N DISPOSAL OF SIGN SYSTEM, STEELBEAM | 2.000 EA | 845.00000 | 1,690.00 |
| 0171 | 4155000000-N DISPOSAL OF SIGN SYSTEM, U- CHANNEL | 45.000 EA | 85.00000 | 3,825.00 |
| 0172 | 4400000000-E WORK ZONE SIGNS (STATIONARY) | 2,376.000 SF | 6.00000 | 14,256.00 |
| 0173 | 4405000000-E WORK ZONE SIGNS (PORTABLE) | 429.000 SF | 14.00000 | 6,006.00 |
| 0174 | 4410000000-E WORK ZONE SIGNS (BARRICADE MOUNTED) | 474.000 SF | 7.00000 | 3,318.00 |
| 0175 | 4415000000-N FLASHING ARROW BOARD | 4.000 EA | 4,000.00000 | 16,000.00 |
| 0176 | 4420000000-N PORTABLE CHANGEABLE MESSAGE SIGN | 6.000 EA | 14,000.00000 | 84,000.00 |

(Contains bid errors)

Check: 4D6CE8E0 Page 15

Contract ID: C203844

Project(s): STATE FUNDED

Letting Date: 05-16-17 Call Order: 005

Bidder: 3424 - Thalle Construction Company

| Line No. | Item Description | Approx. Quantity and Units | Unit Price Dollars Cts | Bid Amount Dollars Ct |
|----------|--|----------------------------|--------------------------|-------------------------|
| 0177 | 4422000000-N PORTABLE CHANGEABLE MESSAGE SIGN (SHORT TERM) | 84.000 DAY | 260.00000 | 21,840.00 |
| 0178 | 4430000000-N DRUMS | 1,050.000 EA | 45.00000 | 47,250.00 |
| 0179 | 4435000000-N CONES | 70.000 EA | 25.00000 | 1,750.00 |
| 0180 | 4445000000-E BARRICADES (TYPE III) | 512.000 LF | 21.00000 | 10,752.00 |
| 0181 | 4450000000-N FLAGGER | 80.000 HR | 40.00000 | 3,200.00 |
| 0182 | 4455000000-N FLAGGER | 240.000 DAY | 360.00000 | 86,400.00 |
| 0183 | 4465000000-N TEMPORARY CRASH CUSHIONS | 10.000 EA | 5,000.00000 | 50,000.00 |
| 0184 | 4470000000-N RESET TEMPORARY CRASH CUSHION | 6.000 EA | 1,500.00000 | 9,000.00 |
| 0185 | 4480000000-N TMA | 2.000 EA | 18,000.00000 | 36,000.00 |
| 0186 | 4485000000-E PORTABLE CONCRETE BARRIER | 4,200.000 LF | 17.65000 | 74,130.00 |
| 0187 | 4490000000-E PORTABLE CONCRETE BARRIER (ANCHORED) | 200.000 LF | 29.25000 | 5,850.00 |
| 0188 | 4500000000-E RESET PORTABLE CONCRETE BARRIER | 1,800.000 LF | 3.75000 | 6,750.00 |

(Contains bid errors)

Check: 4D6CE8E0 Page 16

Contract ID: C203844

Project(s): STATE FUNDED

Letting Date: 05-16-17 Call Order: 005

Bidder: 3424 - Thalle Construction Company

| Line No. | Item Description | Approx. Quantity and Units | Unit Price Dollars Cts | Bid Amount Dollars Ct |
|----------|---|----------------------------|--------------------------|-------------------------|
| 0189 | 4520000000-N TUBULAR MARKERS (FIXED) | 13.000 EA | 100.00000 | 1,300.00 |
| 0190 | 4590000000-E GENERIC TRAFFIC CONTROL ITEM WORK ZONE "PERFORMANCE" PAVEMENT MARKING LINES (6") | 7,800.000 LF | 1.25000 | 9,750.00 |
| 0191 | 4595000000-E GENERIC TRAFFIC CONTROL ITEM WORK ZONE TRAFFIC "PATTERN MASKING" | 437,000.000 SF | 0.23000 | 100,510.00 |
| 0192 | 4600000000-N GENERIC TRAFFIC CONTROL ITEM SEQUENTIAL FLASHING WARNING LIGHTS | 24.000 EA | 300.00000 | 7,200.00 |
| 0193 | 4650000000-N TEMPORARY RAISED PAVEMENT MARKERS | 831.000 EA | 8.00000 | 6,648.00 |
| 0194 | 4685000000-E THERMOPLASTIC PAVEMENT MARKING LINES (4", 90 MILS) | 83,000.000 LF | 0.79000 | 65,570.00 |
| 0195 | 4686000000-E THERMOPLASTIC PAVEMENT MARKING LINES (4", 120 MILS) | 67,850.000 LF | 0.89000 | 60,386.50 |
| 0196 | 4688000000-E THERMOPLASTIC PAVEMENT MARKING LINES (6", 90 MILS) | 5,000.000 LF | 0.99000 | 4,950.00 |
| 0197 | 4690000000-E THERMOPLASTIC PAVEMENT MARKING LINES (6", 120 MILS) | 2,150.000 LF | 1.19000 | 2,558.50 |
| 0198 | 4695000000-E THERMOPLASTIC PAVEMENT MARKING LINES (8", 90 MILS) | 7,500.000 LF | 2.00000 | 15,000.00 |
| 0199 | 4697000000-E THERMOPLASTIC PAVEMENT MARKING LINES (8", 120 MILS) | 4,000.000 LF | 2.00000 | 8,000.00 |

(Contains bid errors)

Check: 4D6CE8E0 Page 17

Contract ID: C203844

Project(s): STATE FUNDED

Letting Date: 05-16-17 Call Order: 005

Bidder: 3424 - Thalle Construction Company

| Line No. | Item Description | Approx. Quantity and Units | Unit Price Dollars Cts | Bid Amount Dollars Ct |
|----------|---|----------------------------|--------------------------|-------------------------|
| 0200 | 4700000000-E THERMOPLAST IC PAVEMENT MARKING LINES (12", 90 MILS) | 17,000.000 LF | 3.50000 | 59,500.00 |
| 0201 | 4710000000-E THERMOPLAST IC PAVEMENT MARKING LINES (24", 120 MILS) | 2,600.000 LF | 12.00000 | 31,200.00 |
| 0202 | 4721000000-E THERMOPLAST IC PAVEMENT MARKING CHARACTER (120 MILS) | 32.000 EA | 90.00000 | 2,880.00 |
| 0203 | 4725000000-E THERMOPLAST IC PAVEMENT MARKING SYMBOL (90 MILS) | 300.000 EA | 175.00000 | 52,500.00 |
| 0204 | 4770000000-E COLD APPLIED PLASTIC PAVEMENT MARKING LINES, TYPE ** (4") (II) | 3,501.000 LF | 1.90000 | 6,651.90 |
| 0205 | 4770000000-E COLD APPLIED PLASTIC PAVEMENT MARKING LINES, TYPE ** (4") (IV) | 1,175.000 LF | 1.90000 | 2,232.50 |
| 0206 | 4780000000-E COLD APPLIED PLASTIC PAVEMENT MARKING LINES, TYPE ** (8") (II) | 30.000 LF | 3.80000 | 114.00 |
| 0207 | 4805000000-N COLD APPLIED PLASTIC PAVEMENT MARKING SYMBOL, TYPE ** (II) | 9.000 EA | 250.00000 | 2,250.00 |
| 0208 | 4810000000-E PAINT PAVEMENT MARKING LINES (4") | 601,688.000 LF | 0.12000 | 72,202.56 |
| 0209 | 4815000000-E PAINT PAVEMENT MARKING LINES (6") | 13,200.000 LF | 0.20000 | 2,640.00 |

Contract ID: C203844

Project(s): STATE FUNDED

Letting Date: 05-16-17 Call Order: 005

Bidder: 3424 - Thalle Construction Company

| Line No. | Item Description | Approx. Quantity and Units | Unit Price | | Bid Amount | |
|----------|---|----------------------------|------------|-----|------------|----|
| | | | Dollars | Cts | Dollars | Ct |
| 0210 | 4820000000-E PAINT PAVEMENT MARKING LINES (8") | 9,510.000 LF | 1.00000 | | 9,510.00 | |
| 0211 | 4825000000-E PAINT PAVEMENT MARKING LINES (12") | 9,400.000 LF | 1.00000 | | 9,400.00 | |
| 0212 | 4835000000-E PAINT PAVEMENT MARKING LINES (24") | 7,980.000 LF | 3.00000 | | 23,940.00 | |
| 0213 | 4840000000-N PAINT PAVEMENT MARKING CHARAC-TER | 20.000 EA | 35.00000 | | 700.00 | |
| 0214 | 4845000000-N PAINT PAVEMENT MARKING SYMBOL | 457.000 EA | 35.00000 | | 15,995.00 | |
| 0215 | 4850000000-E REMOVAL OF PAVEMENT MARKING LINES (4") | 21,000.000 LF | 0.75000 | | 15,750.00 | |
| 0216 | 4855000000-E REMOVAL OF PAVEMENT MARKING LINES (6") | 6,975.000 LF | 0.75000 | | 5,231.25 | |
| 0217 | 4860000000-E REMOVAL OF PAVEMENT MARKING LINES (8") | 900.000 LF | 1.00000 | | 900.00 | |
| 0218 | 4870000000-E REMOVAL OF PAVEMENT MARKING LINES (24") | 200.000 LF | 3.00000 | | 600.00 | |
| 0219 | 4875000000-N REMOVAL OF PAVEMENT MARKING SYMBOLS & CHARACTERS | 23.000 EA | 30.00000 | | 690.00 | |
| 0220 | 4900000000-N PERMANENT RAISED PAVEMENT MARKERS | 1,390.000 EA | 8.00000 | | 11,120.00 | |
| 0221 | 4905000000-N SNOWPLOWABL E PAVEMENT MARKERS | 84.000 EA | 75.00000 | | 6,300.00 | |

(Contains bid errors)

Check: 4D6CE8E0 Page 19

Contract ID: C203844

Project(s): STATE FUNDED

Letting Date: 05-16-17 Call Order: 005

Bidder: 3424 - Thalle Construction Company

| Line No. | Item Description | Approx. Quantity and Units | Unit Price Dollars Cts | Bid Amount Dollars Ct |
|----------|--|----------------------------|--------------------------|-------------------------|
| 0222 | 5255000000-N PORTABLE LIGHTING | LUMP | LUMP | 50,000.00 |
| 0223 | 5546000000-E 8" VALVE | 5.000 EA | 650.00000 | 3,250.00 |
| 0224 | 5589200000-E 2" AIR RELEASE VALVE | 2.000 EA | 3,500.00000 | 7,000.00 |
| 0225 | 5709400000-E 8" FORCE MAIN SEWER | 2,799.000 LF | 50.00000 | 139,950.00 |
| 0226 | 5769000000-E DUCTILE IRON SEWER PIPE FITTINGS | 440.000 LB | 1.60000 | 704.00 |
| 0227 | 5801000000-E ABANDON 8" UTILITY PIPE | 2,745.000 LF | 7.00000 | 19,215.00 |
| 0228 | 5871500000-E TRENCHLESS INSTALLATION OF 8" IN SOIL | 245.000 LF | 110.00000 | 26,950.00 |
| 0229 | 5871510000-E TRENCHLESS INSTALLATION OF 8" NOT IN SOIL | 245.000 LF | 360.00000 | 88,200.00 |
| 0230 | 6000000000-E TEMPORARY SILT FENCE | 120,000.000 LF | 1.90000 | 228,000.00 |
| 0231 | 6006000000-E STONE FOR EROSION CONTROL, CLASS A | 3,080.000 TON | 55.00000 | 169,400.00 |
| 0232 | 6009000000-E STONE FOR EROSION CONTROL, CLASS B | 11,500.000 TON | 58.00000 | 667,000.00 |
| 0233 | 6012000000-E SEDIMENT CONTROL STONE | 27,500.000 TON | 20.00000 | 550,000.00 |

(Contains bid errors)

Check: 4D6CE8E0 Page 20

Contract ID: C203844

Project(s): STATE FUNDED

Letting Date: 05-16-17 Call Order: 005

Bidder: 3424 - Thalle Construction Company

| Line No. | Item Description | Approx. Quantity and Units | Unit Price Dollars Cts | Bid Amount Dollars Ct |
|----------|---|----------------------------|--------------------------|-------------------------|
| 0234 | 6015000000-E TEMPORARY MULCHING | 148.000 | 1,200.00000 | 177,600.00 |
| | | ACR | | |
| 0235 | 6018000000-E SEED FOR TEMPORARY SEEDING | 7,200.000 | 1.50000 | 10,800.00 |
| | | LB | | |
| 0236 | 6021000000-E FERTILIZER FOR TEMPORARY SEED-ING | 38.000 | 990.00000 | 37,620.00 |
| | | TON | | |
| 0237 | 6024000000-E TEMPORARY SLOPE DRAINS | 6,200.000 | 40.00000 | 248,000.00 |
| | | LF | | |
| 0238 | 6029000000-E SAFETY FENCE | 4,400.000 | 1.90000 | 8,360.00 |
| | | LF | | |
| 0239 | 6030000000-E SILT EXCAVATION | 110,000.000 | 0.01000 | 1,100.00 |
| | | CY | | |
| 0240 | 6036000000-E MATTING FOR EROSION CONTROL | 140,000.000 | 1.50000 | 210,000.00 |
| | | SY | | |
| 0241 | 6037000000-E COIR FIBER MAT | 565.000 | 8.00000 | 4,520.00 |
| | | SY | | |
| 0242 | 6038000000-E PERMANENT SOIL REINFORCEMENT MAT | 13,220.000 | 7.75000 | 102,455.00 |
| | | SY | | |
| 0243 | 6042000000-E 1/4" HARDWARE CLOTH | 16,620.000 | 3.00000 | 49,860.00 |
| | | LF | | |
| 0244 | 6045000000-E *** TEMPORARY PIPE (18") | 160.000 | 35.00000 | 5,600.00 |
| | | LF | | |
| 0245 | 6046000000-E TEMPORARY PIPE FOR STREAM CROSSING | 300.000 | 70.00000 | 21,000.00 |
| | | LF | | |

(Contains bid errors)

Check: 4D6CE8E0 Page 21

Contract ID: C203844

Project(s): STATE FUNDED

Letting Date: 05-16-17 Call Order: 005

Bidder: 3424 - Thalle Construction Company

| Line No. | Item Description | Approx. Quantity and Units | Unit Price Dollars Cts | Bid Amount Dollars Ct |
|----------|---|----------------------------|--------------------------|-------------------------|
| 0246 | 6048000000-E FLOATING TURBIDITY CURTAIN | 520.000 SY | 3.00000 | 1,560.00 |
| 0247 | 6069000000-E STILLING BASINS | 750.000 CY | 9.00000 | 6,750.00 |
| 0248 | 6070000000-N SPECIAL STILLING BASINS | 4.000 EA | 1,000.00000 | 4,000.00 |
| 0249 | 6071012000-E COIR FIBER WATTLE | 10,800.000 LF | 7.00000 | 75,600.00 |
| 0250 | 6071020000-E POLYACRYLAMIDE (PAM) | 8,100.000 LB | 4.00000 | 32,400.00 |
| 0251 | 6071030000-E COIR FIBER BAFFLE | 9,825.000 LF | 3.90000 | 38,317.50 |
| 0252 | 6071050000-E *** SKIMMER (1-1/2") | 33.000 EA | 2,200.00000 | 72,600.00 |
| 0253 | 6071050000-E *** SKIMMER (2") | 11.000 EA | 2,400.00000 | 26,400.00 |
| 0254 | 6071050000-E *** SKIMMER (2-1/2") | 2.000 EA | 2,600.00000 | 5,200.00 |
| 0255 | 6071050000-E *** SKIMMER (3") | 1.000 EA | 3,000.00000 | 3,000.00 |
| 0256 | 6084000000-E SEEDING & MULCHING | 102.000 ACR | 2,185.00000 | 222,870.00 |
| 0257 | 6087000000-E MOWING | 90.000 ACR | 118.00000 | 10,620.00 |

(Contains bid errors)

Check: 4D6CE8E0 Page 22

Contract ID: C203844

Project(s): STATE FUNDED

Letting Date: 05-16-17 Call Order: 005

Bidder: 3424 - Thalle Construction Company

| Line No. | Item Description | Approx. Quantity and Units | Unit Price Dollars Cts | Bid Amount Dollars Ct |
|----------|--|----------------------------|--------------------------|-------------------------|
| 0258 | 6090000000-E SEED FOR REPAIR SEEDING | 1,500.000 LB | 9.50000 | 14,250.00 |
| 0259 | 6093000000-E FERTILIZER FOR REPAIR SEEDING | 3.750 TON | 2,350.00000 | 8,812.50 |
| 0260 | 6096000000-E SEED FOR SUPPLEMENTAL SEEDING | 2,325.000 LB | 2.00000 | 4,650.00 |
| 0261 | 6108000000-E FERTILIZER TOPDRESSING | 70.000 TON | 970.00000 | 67,900.00 |
| 0262 | 6111000000-E IMPERVIOUS DIKE | 400.000 LF | 185.00000 | 74,000.00 |
| 0263 | 6114500000-N SPECIALIZED HAND MOWING | 500.000 MHR | 24.50000 | 12,250.00 |
| 0264 | 6117000000-N RESPONSE FOR EROSION CONTROL | 100.000 EA | 200.00000 | 20,000.00 |
| 0265 | 6120000000-E CULVERT DIVERSION CHANNEL | 1,350.000 CY | 21.00000 | 28,350.00 |
| 0266 | 6123000000-E REFORESTATION | 5.000 ACR | 750.00000 | 3,750.00 |
| 0267 | 6126000000-E STREAMBANK REFORESTATION | 0.320 ACR | 5,000.00000 | 1,600.00 |
| 0268 | 6132000000-N GENERIC EROSION CONTROL ITEM CONCRETE WASHOUT STRUCTURE | 16.000 EA | 490.00000 | 7,840.00 |

Contract ID: C203844

Project(s): STATE FUNDED

Letting Date: 05-16-17 Call Order: 005

Bidder: 3424 - Thalle Construction Company

| Line No. | Item Description | Approx. Quantity and Units | Unit Price | | Bid Amount | |
|----------|---|----------------------------|-------------|-----|------------|----|
| | | | Dollars | Cts | Dollars | Ct |
| 0269 | 7048500000-E PEDESTRIAN SIGNAL HEAD (16", 1SECTION W/COUNTDOWN) | 34.000 EA | 870.00000 | | 29,580.00 | |
| 0270 | 7060000000-E SIGNAL CABLE | 23,925.000 LF | 2.40000 | | 57,420.00 | |
| 0271 | 7120000000-E VEHICLE SIGNAL HEAD (12", 3 SECTION) | 123.000 EA | 650.00000 | | 79,950.00 | |
| 0272 | 7132000000-E VEHICLE SIGNAL HEAD (12", 4 SECTION) | 10.000 EA | 0.00000 | | 0.00 | |
| 0273 | 7144000000-E VEHICLE SIGNAL HEAD (12", 5 SECTION) | 11.000 EA | 1,125.00000 | | 12,375.00 | |
| 0274 | 7252000000-E MESSENGER CABLE (1/4") | 10,455.000 LF | 1.50000 | | 15,682.50 | |
| 0275 | 7279000000-E TRACER WIRE | 3,800.000 LF | 0.50000 | | 1,900.00 | |
| 0276 | 7300000000-E UNPAVED TRENCHING (***** (1, 2") | 8,910.000 LF | 6.55000 | | 58,360.50 | |
| 0277 | 7300100000-E UNPAVED TRENCHING FOR TEMP-ORARY LEAD-IN | 1,965.000 LF | 3.05000 | | 5,993.25 | |
| 0278 | 7301000000-E DIRECTIONAL DRILL (***** (1, 2") | 425.000 LF | 15.25000 | | 6,481.25 | |
| 0279 | 7301000000-E DIRECTIONAL DRILL (***** (2, 2") | 175.000 LF | 16.50000 | | 2,887.50 | |
| 0280 | 7324000000-N JUNCTION BOX (STANDARD SIZE) | 92.000 EA | 280.00000 | | 25,760.00 | |

(Contains bid errors)

Check: 4D6CE8E0 Page 24

Contract ID: C203844 Project(s): STATE FUNDED

Letting Date: 05-16-17 Call Order: 005

Bidder: 3424 - Thalle Construction Company

| Line No. | Item Description | Approx. Quantity and Units | Unit Price Dollars Cts | Bid Amount Dollars Ct |
|----------|--|----------------------------|--------------------------|-------------------------|
| 0281 | 7348000000-N JUNCTION BOX (OVER-SIZED, HEA-VY DUTY) | 21.000 EA | 505.00000 | 10,605.00 |
| 0282 | 7360000000-N WOOD POLE | 15.000 EA | 915.00000 | 13,725.00 |
| 0283 | 7372000000-N GUY ASSEMBLY | 36.000 EA | 290.00000 | 10,440.00 |
| 0284 | 7408000000-E 1" RISER WITH WEATHERHEAD | 4.000 EA | 640.00000 | 2,560.00 |
| 0285 | 7420000000-E 2" RISER WITH WEATHERHEAD | 12.000 EA | 425.00000 | 5,100.00 |
| 0286 | 7432000000-E 2" RISER WITH HEAT SHRINK TUBING | 10.000 EA | 480.00000 | 4,800.00 |
| 0287 | 7444000000-E INDUCTIVE LOOP SAWCUT | 15,125.000 LF | 6.50000 | 98,312.50 |
| 0288 | 7456000000-E LEAD-IN CABLE (***** (14-2) | 43,725.000 LF | 1.70000 | 74,332.50 |
| 0289 | 7481000000-N SITE SURVEY | 2.000 EA | 460.00000 | 920.00 |
| 0290 | 7481220000-N CAMERA WITH INTERNAL LOOP EMU-LATOR PROCESSING UNIT | 4.000 EA | 4,080.00000 | 16,320.00 |
| 0291 | 7481280000-N RELOCATE CAMERA SENSOR UNIT | 2.000 EA | 75.00000 | 150.00 |
| 0292 | 7516000000-E COMMUNICATI ONS CABLE (**FIBER) (12) | 3,500.000 LF | 1.60000 | 5,600.00 |

(Contains bid errors)

Contract ID: C203844

Project(s): STATE FUNDED

Letting Date: 05-16-17 Call Order: 005

Bidder: 3424 - Thalle Construction Company

| Line No. | Item Description | Approx. Quantity and Units | Unit Price Dollars Cts | Bid Amount Dollars Ct |
|----------|---|----------------------------|--------------------------|-------------------------|
| 0293 | 7516000000-E COMMUNICATIONS CABLE (**FIBER) (24) | 5,800.000 | 1.70000 | 9,860.00 |
| | | LF | | |
| 0294 | 7540000000-N SPLICE ENCLOSURE | 5.000 | 1,830.00000 | 9,150.00 |
| | | EA | | |
| 0295 | 7552000000-N INTERCONNECT CENTER | 7.000 | 1,595.00000 | 11,165.00 |
| | | EA | | |
| 0296 | 7564000000-N FIBER-OPTIC TRANSCEIVER, DROP & REPEAT | 7.000 | 2,010.00000 | 14,070.00 |
| | | EA | | |
| 0297 | 7566000000-N DELINEATOR MARKER | 13.000 | 145.00000 | 1,885.00 |
| | | EA | | |
| 0298 | 7575142000-N 900MHZ RADIO | 3.000 | 3,435.00000 | 10,305.00 |
| | | EA | | |
| 0299 | 7575160000-E REMOVE EXISTING COMMUNICATIONS CABLE | 1,200.000 | 1.20000 | 1,440.00 |
| | | LF | | |
| 0300 | 7576000000-N METAL STRAIN SIGNAL POLE | 32.000 | 6,680.00000 | 213,760.00 |
| | | EA | | |
| 0301 | 7588000000-N METAL POLE WITH SINGLE MAST ARM | 2.000 | 7,875.00000 | 15,750.00 |
| | | EA | | |
| 0302 | 7590000000-N METAL POLE WITH DUAL MAST ARM | 2.000 | 16,750.00000 | 33,500.00 |
| | | EA | | |
| 0303 | 7613000000-N SOIL TEST | 36.000 | 855.00000 | 30,780.00 |
| | | EA | | |
| 0304 | 7614100000-E DRILLED PIER FOUNDATION | 216.000 | 805.00000 | 173,880.00 |
| | | CY | | |

(Contains bid errors)

Check: 4D6CE8E0 Page 26

Contract ID: C203844 Project(s): STATE FUNDED

Letting Date: 05-16-17 Call Order: 005

Bidder: 3424 - Thalle Construction Company

| Line No. | Item Description | Approx. Quantity and Units | Unit Price Dollars Cts | Bid Amount Dollars Ct |
|--------------------|---|----------------------------|--------------------------|-------------------------|
| 0305 | 7631000000-N MAST ARM WITH METAL POLE DE-SIGN | 4.000 EA | 60.00000 | 240.00 |
| 0306 | 7636000000-N SIGN FOR SIGNALS | 38.000 EA | 195.00000 | 7,410.00 |
| 0307 | 7642100000-N TYPE I POST WITH FOUNDATION | 2.000 EA | 1,130.00000 | 2,260.00 |
| 0308 | 7642200000-N TYPE II PEDESTAL WITH FOUNDATION | 28.000 EA | 1,575.00000 | 44,100.00 |
| 0309 | 7684000000-N SIGNAL CABINET FOUNDATION | 10.000 EA | 1,000.00000 | 10,000.00 |
| 0310 | 7756000000-N CONTROLLER WITH CABINET (TYPE 2070L, BASE MOUNTED) | 10.000 EA | 12,000.00000 | 120,000.00 |
| 0311 | 7768000000-N CONTROLLER WITH CABINET (TYPE 2070L, POLE MOUNTED) | 2.000 EA | 11,350.00000 | 22,700.00 |
| 0312 | 7780000000-N DETECTOR CARD (TYPE 2070L) | 69.000 EA | 135.00000 | 9,315.00 |
| 0313 | 7901000000-N CABINET BASE EXTENDER | 10.000 EA | 335.00000 | 3,350.00 |
| 0314 | 7980000000-N GENERIC SIGNAL ITEM MICROWAVE VEHICLE DETECTOR - SINGLE ZONE | 2.000 EA | 1,125.00000 | 2,250.00 |
| Section 0001 Total | | | | 35,747,279.94 |

Section 0002 CULVERT ITEMS

Alt Group

(Contains bid errors)

Contract ID: C203844 Project(s): STATE FUNDED

Letting Date: 05-16-17 Call Order: 005

Bidder: 3424 - Thalle Construction Company

| Line No. | Item Description | Approx. Quantity and Units | Unit Price Dollars Cts | Bid Amount Dollars Ct |
|--------------------|---|----------------------------|--------------------------|-------------------------|
| 0315 | 8035000000-N REMOVAL OF EXISTING STRUCTURE AT STATION ***** (19+77.00-Y10-) | LUMP | LUMP | 1,538.45 |
| 0316 | 8126000000-N CULVERT EXCAVATION, STA ***** (179+55.00-L-) | LUMP | LUMP | 1,185.73 |
| 0317 | 8126000000-N CULVERT EXCAVATION, STA ***** (19+77.00-Y10-) | LUMP | LUMP | 2,973.13 |
| 0318 | 8126000000-N CULVERT EXCAVATION, STA ***** (96+88.00 -L-) | LUMP | LUMP | 12,850.76 |
| 0319 | 8133000000-E FOUNDATION CONDITIONING MATERIAL, BOX CULVERT | 888.000 TON | 35.00000 | 31,080.00 |
| 0320 | 8196000000-E CLASS A CONCRETE (CULVERT) | 1,200.600 CY | 440.18000 | 528,480.11 |
| 0321 | 8245000000-E REINFORCING STEEL (CULVERT) | 142,445.000 LB | 1.00000 | 142,445.00 |
| Section 0002 Total | | | | 720,553.18 |

Section 0003 WALL ITEMS

Alt Group

| | | | | |
|------|--|--------------|-----------|------------|
| 0322 | 8801000000-E MSE RETAINING WALL NO **** (1) | 3,449.000 SF | 130.00000 | 448,370.00 |
| 0323 | 8801000000-E MSE RETAINING WALL NO **** (2) | 4,617.000 SF | 135.00000 | 623,295.00 |
| 0324 | 8802030000-E SEGMENTAL GRAVITY RETAINING WALLS | 263.000 SF | 30.00000 | 7,890.00 |

Contract ID: C203844 Project(s): STATE FUNDED
 Letting Date: 05-16-17 Call Order: 005
 Bidder: 3424 - Thalle Construction Company

| Line No. | Item Description | Approx. Quantity and Units | Unit Price Dollars Cts | Bid Amount Dollars Ct |
|----------|--------------------|----------------------------|--------------------------|-------------------------|
| | Section 0003 Total | | | 1,079,555.00 |

Section 0004 STRUCTURE ITEMS

Alt Group

| | | | | |
|------|--|--------|-------------|-----------|
| 0325 | 8091000000-N FOUNDATION EXCAVATION FOR BENT** AT STATION (1,146+61.35-L-NBL) | LUMP | LUMP | 1,000.00 |
| 0326 | 8091000000-N FOUNDATION EXCAVATION FOR BENT** AT STATION (1,146+61.35-L-SBL) | LUMP | LUMP | 1,000.00 |
| 0327 | 8091000000-N FOUNDATION EXCAVATION FOR BENT** AT STATION (2,146+61.35-L-NBL) | LUMP | LUMP | 1,000.00 |
| 0328 | 8091000000-N FOUNDATION EXCAVATION FOR BENT** AT STATION (2,146+61.35-L-SBL) | LUMP | LUMP | 1,000.00 |
| 0329 | 8091000000-N FOUNDATION EXCAVATION FOR BENT** AT STATION (3,146+61.35-L-NBL) | LUMP | LUMP | 1,000.00 |
| 0330 | 8091000000-N FOUNDATION EXCAVATION FOR BENT** AT STATION (3,146+61.35-L-SBL) | LUMP | LUMP | 1,000.00 |
| 0331 | 8105560000-E 4'-0" DIA DRILLED PIERS IN SOIL | 70.300 | 687.36000 | 48,321.41 |
| 0332 | 8105660000-E 4'-0" DIA DRILLED PIERS NOT IN SOIL | 31.000 | 2,323.91000 | 72,041.21 |

Contract ID: C203844 Project(s): STATE FUNDED

Letting Date: 05-16-17 Call Order: 005

Bidder: 3424 - Thalle Construction Company

| Line No. | Item Description | Approx. Quantity and Units | Unit Price Dollars Cts | Bid Amount Dollars Ct |
|----------|--|----------------------------|--------------------------|-------------------------|
| 0333 | 8112730000-N PDA TESTING | 1.000 EA | 3,400.00000 | 3,400.00 |
| 0334 | 8113000000-N SID INSPECTIONS | 3.000 EA | 500.00000 | 1,500.00 |
| 0335 | 8114000000-N SPT TESTING | 3.000 EA | 2,000.00000 | 6,000.00 |
| 0336 | 8115000000-N CSL TESTING | 1.000 EA | 3,000.00000 | 3,000.00 |
| 0337 | 8147000000-E REINFORCED CONCRETE DECK SLAB | 46,347.000 SF | 37.32000 | 1,729,670.04 |
| 0338 | 8161000000-E GROOVING BRIDGE FLOORS | 42,545.000 SF | 0.61000 | 25,952.45 |
| 0339 | 8182000000-E CLASS A CONCRETE (BRIDGE) | 871.600 CY | 1,159.00000 | 1,010,184.40 |
| 0340 | 8210000000-N BRIDGE APPROACH SLABS, STATION***** (146+61.35-L-NBL) | LUMP | LUMP | 65,000.00 |
| 0341 | 8210000000-N BRIDGE APPROACH SLABS, STATION***** (146+61.35-L-SBL) | LUMP | LUMP | 65,000.00 |
| 0342 | 8210000000-N BRIDGE APPROACH SLABS, STATION***** (26+54.73-NBL-) | LUMP | LUMP | 130,000.00 |
| 0343 | 8217000000-E REINFORCING STEEL (BRIDGE) | 143,844.000 LB | 1.00000 | 143,844.00 |

Contract ID: C203844

Project(s): STATE FUNDED

Letting Date: 05-16-17 Call Order: 005

Bidder: 3424 - Thalle Construction Company

| Line No. | Item Description | Approx. Quantity and Units | Unit Price Dollars Cts | Bid Amount Dollars Ct |
|----------|--|----------------------------|--------------------------|-------------------------|
| 0344 | 8238000000-E SPIRAL COLUMN REINFORCING STEEL (BRIDGE) | 14,778.000 LB | 2.00000 | 29,556.00 |
| 0345 | 8277000000-E MODIFIED 72" PRESTRESSED CONC GIRDERS | 3,901.130 LF | 400.00000 | 1,560,452.00 |
| 0346 | 8280000000-E APPROX LBS STRUCTURALSTEEL | LUMP | LUMP | 1,600,000.00 |
| 0347 | 8328200000-E PILE DRIVING EQUIPMENT SETUP FOR *** STEEL PILES (HP 12 X 53) | 132.000 EA | 345.00000 | 45,540.00 |
| 0348 | 8364000000-E HP12X53 STEEL PILES | 8,200.000 LF | 55.00000 | 451,000.00 |
| 0349 | 8475000000-E TWO BAR METAL RAIL | 472.380 LF | 36.00000 | 17,005.68 |
| 0350 | 8503000000-E CONCRETE BARRIER RAIL | 2,050.400 LF | 90.00000 | 184,536.00 |
| 0351 | 8517000000-E 1'-***"X *****" CONCRETE PARA- (1'-2" X 2'-6") | 243.690 LF | 80.00000 | 19,495.20 |
| 0352 | 8517000000-E 1'-***"X *****" CONCRETE PARA- (1'-2" X 3'-0 1/2") | 243.690 LF | 80.00000 | 19,495.20 |
| 0353 | 8531000000-E 4" SLOPE PROTECTION | 905.000 SY | 150.00000 | 135,750.00 |
| 0354 | 8657000000-N ELASTOMERIC BEARINGS | LUMP | LUMP | 75,000.00 |

Contract ID: C203844 Project(s): STATE FUNDED

Letting Date: 05-16-17 Call Order: 005

Bidder: 3424 - Thalle Construction Company

| Line No. | Item Description | Approx. Quantity and Units | Unit Price Dollars Cts | Bid Amount Dollars Ct |
|--------------------|---|----------------------------|--------------------------|-------------------------|
| 0355 | 8706000000-N EXPANSION JOINT SEALS | LUMP | LUMP | 250,000.00 |
| 0356 | 8727000000-N ELECTRICAL CONDUIT SYSTEM FOR SIGNALS AT STA***** (146+61.35-L- NBL) | LUMP | LUMP | 65,000.00 |
| 0357 | 8867000000-E GENERIC STRUCTURE ITEM TWO BAR METAL RAIL RETROFIT | 426.690 LF | 185.00000 | 78,937.65 |
| Section 0004 Total | | | | 7,841,681.24 |
| Bid Total | | | | 45,389,069.36 |

NON-COLLUSION AND DEBARMENT CERTIFICATION

The bidder certifies that neither he, nor any official, agent or employee of the bidder has entered into any agreement, participated in any collusion, or otherwise taken any action which is in restraint of free competitive bidding in connection with this bid, and that the bidder intends to do the work with its own bonafide employees or subcontractors and is not bidding for the benefit of another contractor. In addition, submitting this electronic bid constitutes the bidder's certification of Status under penalty of perjury under the laws of the United States and in accordance with the Debarment Certification on file with the Department.

By submitting this bid, the bidder certifies to the best of his knowledge and belief that he and his principals:

- a. Are not presently debarred, suspended, proposed for debarment, declared ineligible, or voluntarily excluded from covered transactions by any Federal department or agency;
- b. Have not within a three-year period preceding this proposal been convicted of or had a civil judgment rendered against them for commission of fraud or a criminal offense in connection with obtaining, attempting to obtain, or performing a public (Federal, State or local) transaction or contract under a public transaction; violation of Federal or State antitrust statutes or commission of embezzlement, theft, forgery, bribery, falsification or destruction of records; making false statements; or receiving stolen property;
- c. Are not presently indicted for or otherwise criminally or civilly charged by a governmental entity (Federal, State or local) with commission of any of the offenses enumerated in paragraph b. of this certification; and
- d. Have not within a three-year period preceding this proposal had one or more public transactions (Federal, State or local) terminated for cause or default.

Where the prospective bidder is unable to certify to any of the statements in this certification, the bidder shall submit an explanation in the blanks provided herein. The explanation will not necessarily result in denial of participation in a contract.

Explanation:
NOT ANSWERED
NOT ANSWERED
NOT ANSWERED
NOT ANSWERED

If the prequalified bidder's status changes, he shall immediately submit a new fully executed non-collusion affidavit and debarment certification with an explanation of the change to the Contract Office prior to submitting the bid.

Failure to furnish a certification or an explanation will be grounds for rejection of a bid

AWARD LIMITS ON MULTIPLE PROJECTS

By answering YES to this statement, the bidder acknowledges that they are using the award limits on multiple projects. No

A bidder who desires to bid on more than one project on which bids are to be opened on the same date, and who also desires to avoid receiving an award of more projects than he is equipped to handle, may bid on any number of projects but may limit the total amount of work awarded to him on selected projects by completing the AWARD LIMITS ON MULTIPLE PROJECTS.

The Award Limits on Multiple Projects must be filled in on each project bid for which the Bidder desires protection.

It is the desire of the Bidder to be awarded contracts, the value of which will not exceed a total of NOT ANSWERED for those projects indicated herein, for which bids will be opened on (MM/DD/YY)

The Award Limits shall apply to the following projects:

| Contract Number | County |
|-----------------|--------|
| NOT ANSWERED | |
| NOT ANSWERED | |
| NOT ANSWERED | |
| NOT ANSWERED | |
| NOT ANSWERED | |
| NOT ANSWERED | |

It is agreed that if I am (we are) the low Bidder(s) on indicated projects, the total value of which is more than the above stipulated award limits, the Board of Transportation will award me (us) projects from among those indicated that have a total value not to exceed the award limit and will result in the lowest total bids to the Department of Transportation.

PROPOSAL: C203844
LETTING: L170516 CALL: 005
VENDOR: 3424 Thalle Construction Company

| LINE NO. | ITEM NO. | ITEM DESC. | UNIT TYPE | SUBCONTRACTOR QUANTITY | SUBCONTRACTOR UNIT PRICE | EXTENDED AMOUNT |
|--|--------------|-----------------|-----------|------------------------|--------------------------|-----------------|
| ----- | | | | | | |
| WBE SUBCONTRACTOR: 3376 REYNOLDS FENCE & GUARDRAIL INC | | | | | | |
| Will Use Quote: Yes | | | | | | |
| 0128 | 3000000000-N | IMPACT ATTEN EA | | 2.000 | 16000.00000 | 32000.00 |
| 0139 | 3389100000-N | TEMP GDRL AN EA | | 2.000 | 1300.00000 | 2600.00 |
| 0138 | 3380000000-E | TEMP STL BM LF | | 487.500 | 11.00000 | 5362.50 |
| 0137 | 3360000000-E | REMOVE EXIST LF | | 563.000 | 1.25000 | 703.75 |
| 0136 | 3317000000-N | GR ANCHOR TY EA | | 14.000 | 1580.00000 | 22120.00 |
| 0135 | 3285000000-N | GR ANCHOR TY EA | | 2.000 | 1975.00000 | 3950.00 |
| 0134 | 3270000000-N | GR ANCHOR TY EA | | 30.000 | 1875.00000 | 56250.00 |
| 0133 | 3215000000-N | GR ANCHOR TY EA | | 4.000 | 1500.00000 | 6000.00 |
| 0132 | 3210000000-N | GR ANCHOR TY EA | | 21.000 | 575.00000 | 12075.00 |
| 0131 | 3150000000-N | ADDIT GUARDR EA | | 50.000 | 25.00000 | 1250.00 |
| 0130 | 3105000000-N | SBGR TERM SE EA | | 6.000 | 175.00000 | 1050.00 |
| 0129 | 3030000000-E | STL BM GUARD LF | | 13100.000 | 15.70000 | 205670.00 |

WBE COMMITMENT TOTAL FOR SUBCONTRACTOR: 349,031.25

WBE SUBCONTRACTOR: 4753 STATE CONSTRUCTION CO.
Will Use Quote: Yes

| | | | | | | |
|------|--------------|------------------|--|------------|------------|-----------|
| 0234 | 6015000000-E | TEMPORARY MU ACR | | 148.000 | 1200.00000 | 177600.00 |
| 0235 | 6018000000-E | SEED FOR TEM LB | | 7200.000 | 1.50000 | 10800.00 |
| 0236 | 6021000000-E | FERT FOR TEM TON | | 38.000 | 990.00000 | 37620.00 |
| 0240 | 6036000000-E | MATTING FOR SY | | 140000.000 | 1.50000 | 210000.00 |
| 0241 | 6037000000-E | COIR FIBER M SY | | 565.000 | 8.00000 | 4520.00 |
| 0242 | 6038000000-E | PERM SOIL RE SY | | 13220.000 | 7.75000 | 102455.00 |
| 0256 | 6084000000-E | SEEDING AND ACR | | 102.000 | 2185.00000 | 222870.00 |
| 0257 | 6087000000-E | MOWING ACR | | 90.000 | 118.00000 | 10620.00 |
| 0258 | 6090000000-E | SEED FOR REP LB | | 1500.000 | 9.50000 | 14250.00 |
| 0259 | 6093000000-E | FERT FOR REP TON | | 3.750 | 2350.00000 | 8812.50 |
| 0260 | 6096000000-E | SEED FOR SUP LB | | 2325.000 | 2.00000 | 4650.00 |
| 0261 | 6108000000-E | FERTILIZER T TON | | 70.000 | 970.00000 | 67900.00 |
| 0264 | 6117000000-N | RESPONSE FOR EA | | 100.000 | 200.00000 | 20000.00 |
| 0263 | 6114500000-N | SPECIALIZED MHR | | 500.000 | 24.50000 | 12250.00 |

WBE COMMITMENT TOTAL FOR SUBCONTRACTOR: 904,347.50

WBE SUBCONTRACTOR: Carolina Transport of Greensboro
Will Use Quote: Yes

| | | | | | | |
|------|--------------|------------------|--|-----------|---------|-----------|
| 0065 | 1099700000-E | CLASS IV SUB TON | | 35000.000 | 3.80000 | 133000.00 |
| | | Hauling of stone | | | | |
| 0068 | 1121000000-E | AGGREGATE BA TON | | 3200.000 | 3.80000 | 12160.00 |
| | | Hauling of Stone | | | | |
| 0233 | 6012000000-E | SEDIMENT CON TON | | 27500.000 | 3.80000 | 104500.00 |
| | | Stone Haul | | | | |

| LINE NO. | ITEM NO. | ITEM DESC. | UNIT TYPE | SUBCONTRACTOR QUANTITY | SUBCONTRACTOR UNIT PRICE | EXTENDED AMOUNT |
|----------|--------------|-----------------|-----------|------------------------|--------------------------|-----------------|
| 0232 | 6009000000-E | EROS CONTRL | TON | 11500.000 | 6.63000 | 76245.00 |
| | | Stone Haul | | | | |
| 0231 | 6006000000-E | EROS CONTRL | TON | 3080.000 | 4.01000 | 12350.80 |
| | | Stone haul | | | | |
| 0151 | 3649000000-E | RIP RAP, CLA | TON | 2430.000 | 6.63000 | 16110.90 |
| | | Stone Haul | | | | |
| 0014 | 0195000000-E | SELECT GRANU | CY | 8800.000 | 3.80000 | 33440.00 |
| | | Haul @ 3.80 Ton | | | | |

WBE COMMITMENT TOTAL FOR SUBCONTRACTOR: 387,806.70

WBE SUBCONTRACTOR: 3230 HIATT & MASON ENTERPRISES INC
Will Use Quote: Yes

| | | | | | | |
|------|--------------|-------------|----|------------|---------|----------|
| 0343 | 8217000000-E | REINF STEEL | LB | 143844.000 | 0.19000 | 27330.36 |
| | | Set Rebar | | | | |

WBE COMMITMENT TOTAL FOR SUBCONTRACTOR: 27,330.36

TOTAL WBE COMMITMENT FOR VENDOR: Entered: 2.82% or 1280709.11
Required: 5.00% or 2269453.47
<GOAL NOT MET>

THIS PROPOSAL CONTAINS THE FOLLOWING ERRORS/WARNINGS (IF ANY)

DBE Warning : WBE Warning: WBE Commitment Goal not met
DBE Error : WBE Entry #3 is incomplete
DBE Warning : DBENAME Carolina Transport not chosen from list (WBE #3)

This Bid contains 1 amendment files

00001 05-10-17 MODIFY ITEMS

Electronic Bid Submission

By submitting this bid electronically, I hereby acknowledge that all requirements included in the hard copy proposal, addendum, amendments, plans, standard specifications, supplemental specifications and special provisions are part of the bid and contract. Further, I acknowledge that I have read, understand, accept, acknowledge and agree to comply with all statements in this electronic bid.

I Hereby certify that I have the authority to submit this bid.

Signature

Agency

Date

Contract Item Sheets For C203844

| Line # | ItemNumber | Sec # | Description | Quantity Unit | Unit Bid Price | Amount Bid |
|----------------------|--------------|-------|--|----------------|----------------|--------------|
| ROADWAY ITEMS | | | | | | |
| 0001 | 0000100000-N | 800 | MOBILIZATION | Lump Sum LS | 2,200,000.00 | 2,200,000.00 |
| 0002 | 0000400000-N | 801 | CONSTRUCTION SURVEYING | Lump Sum LS | 350,000.00 | 350,000.00 |
| 0003 | 0001000000-E | 200 | CLEARING & GRUBBING .. ACRE(S) | Lump Sum LS | 1,025,000.00 | 1,025,000.00 |
| 0004 | 0008000000-E | 200 | SUPPLEMENTARY CLEARING & GRUB- BING | 4 ACR | 12,000.00 | 48,000.00 |
| 0005 | 0015000000-N | 205 | SEALING ABANDONED WELLS | 31 EA | 1,750.00 | 54,250.00 |
| 0006 | 0022000000-E | 225 | UNCLASSIFIED EXCAVATION | 377,000 CY | 6.00 | 2,262,000.00 |
| 0007 | 0029000000-N | SP | REINFORCED BRIDGE APPROACH FILL, STATION ***** (26+55 -L-) | Lump Sum LS | 17,533.13 | 17,533.13 |
| 0008 | 0036000000-E | 225 | UNDERCUT EXCAVATION | 72,440 CY | 5.10 | 369,444.00 |
| 0009 | 0106000000-E | 230 | BORROW EXCAVATION | 688,000 CY | 0.01 | 6,880.00 |
| 0010 | 0134000000-E | 240 | DRAINAGE DITCH EXCAVATION | 41,800 CY | 4.50 | 188,100.00 |
| 0011 | 0141000000-E | 240 | BERM DITCH CONSTRUCTION | 1,150 LF | 9.00 | 10,350.00 |
| 0012 | 0156000000-E | 250 | REMOVAL OF EXISTING ASPHALT PAVEMENT | 47,950 SY | 1.50 | 71,925.00 |
| 0013 | 0192000000-N | 260 | PROOF ROLLING | 40 HR | 600.00 | 24,000.00 |
| 0014 | 0195000000-E | 265 | SELECT GRANULAR MATERIAL | 8,800 CY | 43.00 | 378,400.00 |
| 0015 | 0196000000-E | 270 | GEOTEXTILE FOR SOIL STABILIZA- TION | 69,100 SY | 2.00 | 138,200.00 |
| 0016 | 0199000000-E | SP | TEMPORARY SHORING | 2,200 SF | 50.00 | 110,000.00 |
| 0017 | 0220000000-E | SP | ROCK EMBANKMENTS | 1,400 TON | 40.00 | 56,000.00 |
| 0018 | 0222000000-E | SP | GEOTEXTILE FOR ROCK EMBANK- MENTS | 950 SY | 2.00 | 1,900.00 |
| 0019 | 0255000000-E | SP | GENERIC GRADING ITEM STOCKPILING CONTAMINATED SOIL | 100 TON | 23.00 | 2,300.00 |

Contract Item Sheets For C203844

| Line # | ItemNumber | Sec # | Description | Quantity Unit | Unit Bid Price | Amount Bid |
|--------|--------------|-------|---|---------------|----------------|------------|
| 0020 | 0262000000-N | SP | GENERIC GRADING ITEM ENERGY DISSIPATOR BASIN | 1 EA | 2,600.00 | 2,600.00 |
| 0021 | 0314000000-E | SP | SELECT MATERIAL, CLASS ***** (VI) | 4,050 TON | 30.00 | 121,500.00 |
| 0022 | 0318000000-E | 300 | FOUNDATION CONDITIONING MATE- RIAL, MINOR STRUCTURES | 3,550 TON | 33.00 | 117,150.00 |
| 0023 | 0320000000-E | 300 | FOUNDATION CONDITIONING GEO- TEXTILE | 11,140 SY | 1.50 | 16,710.00 |
| 0024 | 0335200000-E | 305 | 15" DRAINAGE PIPE | 4,952 LF | 45.00 | 222,840.00 |
| 0025 | 0335300000-E | 305 | 18" DRAINAGE PIPE | 1,792 LF | 50.00 | 89,600.00 |
| 0026 | 0335400000-E | 305 | 24" DRAINAGE PIPE | 828 LF | 65.00 | 53,820.00 |
| 0027 | 0335500000-E | 305 | 30" DRAINAGE PIPE | 292 LF | 100.00 | 29,200.00 |
| 0028 | 0335600000-E | 305 | 36" DRAINAGE PIPE | 208 LF | 125.00 | 26,000.00 |
| 0029 | 0335700000-E | 305 | 42" DRAINAGE PIPE | 32 LF | 160.00 | 5,120.00 |
| 0030 | 0343000000-E | 310 | 15" SIDE DRAIN PIPE | 1,248 LF | 42.00 | 52,416.00 |
| 0031 | 0344000000-E | 310 | 18" SIDE DRAIN PIPE | 444 LF | 52.00 | 23,088.00 |
| 0032 | 0354000000-E | 310 | **** RC PIPE CULVERTS, CLASS ***** (30", V) | 332 LF | 115.00 | 38,180.00 |
| 0033 | 0366000000-E | 310 | 15" RC PIPE CULVERTS, CLASS III | 2,600 LF | 105.00 | 273,000.00 |
| 0034 | 0372000000-E | 310 | 18" RC PIPE CULVERTS, CLASS III | 936 LF | 95.00 | 88,920.00 |
| 0035 | 0378000000-E | 310 | 24" RC PIPE CULVERTS, CLASS III | 1,168 LF | 75.00 | 87,600.00 |
| 0036 | 0384000000-E | 310 | 30" RC PIPE CULVERTS, CLASS III | 1,000 LF | 92.00 | 92,000.00 |
| 0037 | 0390000000-E | 310 | 36" RC PIPE CULVERTS, CLASS III | 496 LF | 126.00 | 62,496.00 |

| Line # | ItemNumber | Sec # | Description | Quantity Unit | Unit Bid Price | Amount Bid |
|--------|--------------|-------|--|---------------|----------------|------------|
| 0038 | 0396000000-E | 310 | 42" RC PIPE CULVERTS, CLASS III | 704 LF | 155.00 | 109,120.00 |
| 0039 | 0402000000-E | 310 | 48" RC PIPE CULVERTS, CLASS III | 664 LF | 180.00 | 119,520.00 |
| 0040 | 0408000000-E | 310 | 54" RC PIPE CULVERTS, CLASS III | 444 LF | 240.00 | 106,560.00 |
| 0041 | 0414000000-E | 310 | 60" RC PIPE CULVERTS, CLASS III | 116 LF | 290.00 | 33,640.00 |
| 0042 | 0420000000-E | 310 | 66" RC PIPE CULVERTS, CLASS III | 192 LF | 365.00 | 70,080.00 |
| 0043 | 0426000000-E | 310 | 72" RC PIPE CULVERTS, CLASS III | 208 LF | 450.00 | 93,600.00 |
| 0044 | 0448000000-E | 310 | ***** RC PIPE CULVERTS, CLASS IV (48") | 216 LF | 230.00 | 49,680.00 |
| 0045 | 0448000000-E | 310 | ***** RC PIPE CULVERTS, CLASS IV (66") | 220 LF | 450.00 | 99,000.00 |
| 0046 | 0448200000-E | 310 | 15" RC PIPE CULVERTS, CLASS IV | 9,300 LF | 53.00 | 492,900.00 |
| 0047 | 0448300000-E | 310 | 18" RC PIPE CULVERTS, CLASS IV | 1,152 LF | 55.00 | 63,360.00 |
| 0048 | 0448400000-E | 310 | 24" RC PIPE CULVERTS, CLASS IV | 2,148 LF | 80.00 | 171,840.00 |
| 0049 | 0448500000-E | 310 | 30" RC PIPE CULVERTS, CLASS IV | 352 LF | 100.00 | 35,200.00 |
| 0050 | 0448600000-E | 310 | 36" RC PIPE CULVERTS, CLASS IV | 80 LF | 136.00 | 10,880.00 |
| 0051 | 0448700000-E | 310 | 42" RC PIPE CULVERTS, CLASS IV | 344 LF | 170.00 | 58,480.00 |
| 0052 | 0582000000-E | 310 | 15" CS PIPE CULVERTS, 0.064" THICK | 748 LF | 53.00 | 39,644.00 |
| 0053 | 0588000000-E | 310 | 18" CS PIPE CULVERTS, 0.064" THICK | 68 LF | 65.00 | 4,420.00 |
| 0054 | 0594000000-E | 310 | 24" CS PIPE CULVERTS, 0.064" THICK | 124 LF | 75.00 | 9,300.00 |

| Line # | ItemNumber | Sec # | Description | Quantity Unit | Unit Bid Price | Amount Bid |
|--------|--------------|-------|---|----------------|----------------|--------------|
| 0055 | 0636000000-E | 310 | *** CS PIPE ELBOWS, ***** THICK (15", 0.064") | 29 EA | 700.00 | 20,300.00 |
| 0056 | 0636000000-E | 310 | *** CS PIPE ELBOWS, ***** THICK (18", 0.064") | 3 EA | 800.00 | 2,400.00 |
| 0057 | 0636000000-E | 310 | *** CS PIPE ELBOWS, ***** THICK (24", 0.064") | 3 EA | 1,000.00 | 3,000.00 |
| 0058 | 0636000000-E | 310 | *** CS PIPE ELBOWS, ***** THICK (30", 0.079") | 1 EA | 1,300.00 | 1,300.00 |
| 0059 | 0995000000-E | 340 | PIPE REMOVAL | 5,351 LF | 22.00 | 117,722.00 |
| 0060 | 0996000000-N | 350 | PIPE CLEAN-OUT | 1 EA | 6,000.00 | 6,000.00 |
| 0061 | 1011000000-N | 500 | FINE GRADING | Lump Sum LS | 1,200,000.00 | 1,200,000.00 |
| 0062 | 1044000000-E | 501 | LIME TREATED SOIL (SLURRY METHOD) | 71,070 SY | 2.30 | 163,461.00 |
| 0063 | 1066000000-E | 501 | LIME FOR LIME TREATED SOIL | 720 TON | 165.00 | 118,800.00 |
| 0064 | 1099500000-E | 505 | SHALLOW UNDERCUT | 18,500 CY | 7.00 | 129,500.00 |
| 0065 | 1099700000-E | 505 | CLASS IV SUBGRADE STABILIZA- TION | 35,000 TON | 36.00 | 1,260,000.00 |
| 0066 | 1110000000-E | 510 | STABILIZER AGGREGATE | 500 TON | 36.00 | 18,000.00 |
| 0067 | 1115000000-E | SP | GEOTEXTILE FOR PAVEMENT STA- BILIZATION | 57,567 SY | 5.00 | 287,835.00 |
| 0068 | 1121000000-E | 520 | AGGREGATE BASE COURSE | 3,200 TON | 35.00 | 112,000.00 |
| 0069 | 1176000000-E | 542 | SOIL CEMENT BASE | 71,070 SY | 2.20 | 156,354.00 |
| 0070 | 1187000000-E | 542 | PORTLAND CEMENT FOR SOIL CE- MENT BASE | 1,955 TON | 170.00 | 332,350.00 |
| 0071 | 1198000000-E | 542 | AGGREGATE FOR SOIL CEMENT BASE | 1,960 TON | 35.00 | 68,600.00 |
| 0072 | 1209000000-E | 543 | ASPHALT CURING SEAL | 21,350 GAL | 3.20 | 68,320.00 |

| Line # | ItemNumber | Sec # | Description | Quantity Unit | Unit Bid Price | Amount Bid |
|--------|--------------|-------|---|---------------|----------------|--------------|
| 0073 | 1220000000-E | 545 | INCIDENTAL STONE BASE | 1,000 TON | 25.00 | 25,000.00 |
| 0074 | 1275000000-E | 600 | PRIME COAT | 2,555 GAL | 3.50 | 8,942.50 |
| 0075 | 1297000000-E | 607 | MILLING ASPHALT PAVEMENT, **** DEPTH (1-1/2") | 19,790 SY | 2.75 | 54,422.50 |
| 0076 | 1297000000-E | 607 | MILLING ASPHALT PAVEMENT, **** DEPTH (3") | 1,480 SY | 2.75 | 4,070.00 |
| 0077 | 1330000000-E | 607 | INCIDENTAL MILLING | 4,260 SY | 8.00 | 34,080.00 |
| 0078 | 1489000000-E | 610 | ASPHALT CONC BASE COURSE, TYPE B25.0B | 25,050 TON | 48.00 | 1,202,400.00 |
| 0079 | 1491000000-E | 610 | ASPHALT CONC BASE COURSE, TYPE B25.0C | 29,400 TON | 46.00 | 1,352,400.00 |
| 0080 | 1498000000-E | 610 | ASPHALT CONC INTERMEDIATE COURSE, TYPE I19.0B | 21,870 TON | 49.00 | 1,071,630.00 |
| 0081 | 1503000000-E | 610 | ASPHALT CONC INTERMEDIATE COURSE, TYPE I19.0C | 35,700 TON | 47.00 | 1,677,900.00 |
| 0082 | 1519000000-E | 610 | ASPHALT CONC SURFACE COURSE, TYPE S9.5B | 17,600 TON | 51.00 | 897,600.00 |
| 0083 | 1523000000-E | 610 | ASPHALT CONC SURFACE COURSE, TYPE S9.5C | 27,600 TON | 53.00 | 1,462,800.00 |
| 0084 | 1524200000-E | 610 | ASPHALT CONC SURFACE COURSE, TYPE S9.5D | 1,090 TON | 70.00 | 76,300.00 |
| 0085 | 1575000000-E | 620 | ASPHALT BINDER FOR PLANT MIX | 7,845 TON | 425.00 | 3,334,125.00 |
| 0086 | 1577000000-E | 620 | POLYMER MODIFIED ASPHALT BIN- DER FOR PLANT MIX | 65 TON | 650.00 | 42,250.00 |
| 0087 | 1693000000-E | 654 | ASPHALT PLANT MIX, PAVEMENT REPAIR | 1,150 TON | 165.00 | 189,750.00 |
| 0088 | 1840000000-E | 665 | MILLED RUMBLE STRIPS (ASPHALT CONCRETE) | 2,430 LF | 2.64 | 6,415.20 |
| 0089 | 2022000000-E | 815 | SUBDRAIN EXCAVATION | 1,848 CY | 25.00 | 46,200.00 |

| Line # | ItemNumber | Sec # | Description | Quantity Unit | Unit Bid Price | Amount Bid |
|--------|--------------|-------|--|---------------|----------------|------------|
| 0090 | 2033000000-E | 815 | SUBDRAIN FINE AGGREGATE | 924 CY | 55.00 | 50,820.00 |
| 0091 | 2044000000-E | 815 | 6" PERFORATED SUBDRAIN PIPE | 5,500 LF | 14.00 | 77,000.00 |
| 0092 | 2070000000-N | 815 | SUBDRAIN PIPE OUTLET | 11 EA | 350.00 | 3,850.00 |
| 0093 | 2077000000-E | 815 | 6" OUTLET PIPE | 66 LF | 40.00 | 2,640.00 |
| 0094 | 2143000000-E | 818 | BLOTTING SAND | 10 TON | 65.00 | 650.00 |
| 0095 | 2209000000-E | 838 | ENDWALLS | 55.2 CY | 1,300.00 | 71,760.00 |
| 0096 | 2220000000-E | 838 | REINFORCED ENDWALLS | 36.9 CY | 2,400.00 | 88,560.00 |
| 0097 | 2253000000-E | 840 | PIPE COLLARS | 0.447 CY | 1,300.00 | 581.10 |
| 0098 | 2275000000-E | SP | FLOWABLE FILL | 6 CY | 300.00 | 1,800.00 |
| 0099 | 2286000000-N | 840 | MASONRY DRAINAGE STRUCTURES | 278 EA | 3,000.00 | 834,000.00 |
| 0100 | 2297000000-E | 840 | MASONRY DRAINAGE STRUCTURES | 3 CY | 1,200.00 | 3,600.00 |
| 0101 | 2308000000-E | 840 | MASONRY DRAINAGE STRUCTURES | 137.6 LF | 610.00 | 83,936.00 |
| 0102 | 2364000000-N | 840 | FRAME WITH TWO GRATES, STD 840.16 | 29 EA | 850.00 | 24,650.00 |
| 0103 | 2364200000-N | 840 | FRAME WITH TWO GRATES, STD 840.20 | 50 EA | 775.00 | 38,750.00 |
| 0104 | 2365000000-N | 840 | FRAME WITH TWO GRATES, STD 840.22 | 3 EA | 775.00 | 2,325.00 |
| 0105 | 2366000000-N | 840 | FRAME WITH TWO GRATES, STD 840.24 | 64 EA | 775.00 | 49,600.00 |
| 0106 | 2367000000-N | 840 | FRAME WITH TWO GRATES, STD 840.29 | 22 EA | 775.00 | 17,050.00 |
| 0107 | 2374000000-N | 840 | FRAME WITH GRATE & HOOD, STD 840.03, TYPE ** (E) | 18 EA | 920.00 | 16,560.00 |
| 0108 | 2374000000-N | 840 | FRAME WITH GRATE & HOOD, STD 840.03, TYPE ** (F) | 37 EA | 920.00 | 34,040.00 |

Contract Item Sheets For C203844

| Line # | ItemNumber | Sec # | Description | Quantity Unit | Unit Bid Price | Amount Bid |
|--------|--------------|-------|--|---------------|----------------|------------|
| 0109 | 2374000000-N | 840 | FRAME WITH GRATE & HOOD, STD 840.03, TYPE ** (G) | 39 EA | 920.00 | 35,880.00 |
| 0110 | 2396000000-N | 840 | FRAME WITH COVER, STD 840.54 | 17 EA | 685.00 | 11,645.00 |
| 0111 | 2440000000-N | 852 | CONCRETE TRANSITIONAL SECTION FOR CATCH BASIN | 1 EA | 685.00 | 685.00 |
| 0112 | 2451000000-N | 852 | CONCRETE TRANSITIONAL SECTION FOR DROP INLET | 18 EA | 685.00 | 12,330.00 |
| 0113 | 2462000000-E | SP | *** SLUICE GATE (15") | 1 EA | 4,000.00 | 4,000.00 |
| 0114 | 2462000000-E | SP | *** SLUICE GATE (18") | 2 EA | 4,100.00 | 8,200.00 |
| 0115 | 2462000000-E | SP | *** SLUICE GATE (30") | 1 EA | 5,000.00 | 5,000.00 |
| 0116 | 2538000000-E | 846 | ***,*** CONCRETE CURB & GUTTER (2'-9") | 8,650 LF | 15.75 | 136,237.50 |
| 0117 | 2542000000-E | 846 | 1'-6" CONCRETE CURB & GUTTER | 15,730 LF | 12.75 | 200,557.50 |
| 0118 | 2549000000-E | 846 | 2'-6" CONCRETE CURB & GUTTER | 18,400 LF | 15.50 | 285,200.00 |
| 0119 | 2556000000-E | 846 | SHOULDER BERM GUTTER | 4,590 LF | 15.75 | 72,292.50 |
| 0120 | 2591000000-E | 848 | 4" CONCRETE SIDEWALK | 6,650 SY | 27.25 | 181,212.50 |
| 0121 | 2605000000-N | 848 | CONCRETE CURB RAMP | 60 EA | 1,550.00 | 93,000.00 |
| 0122 | 2612000000-E | 848 | 6" CONCRETE DRIVEWAY | 210 SY | 47.50 | 9,975.00 |
| 0123 | 2619000000-E | 850 | 4" CONCRETE PAVED DITCH | 84 SY | 70.25 | 5,901.00 |
| 0124 | 2655000000-E | 852 | 5" MONOLITHIC CONCRETE ISLANDS (KEYED IN) | 7,580 SY | 51.25 | 388,475.00 |
| 0125 | 2710000000-N | 854 | CONCRETE BARRIER TRANSITION SECTION | 1 EA | 12,000.00 | 12,000.00 |
| 0126 | 2724000000-E | 857 | PRECAST REINFORCED CONCRETE BARRIER, SINGLE FACED | 88 LF | 135.00 | 11,880.00 |

| Line # | ItemNumber | Sec # | Description | Quantity Unit | Unit Bid Price | Amount Bid |
|--------|--------------|-------|---|---------------|----------------|------------|
| 0127 | 2752000000-E | SP | GENERIC PAVING ITEM MEDIAN HAZARD PROTECTION | 108 LF | 175.00 | 18,900.00 |
| 0128 | 3000000000-N | SP | IMPACT ATTENUATOR UNIT, TYPE 350 | 2 EA | 16,000.00 | 32,000.00 |
| 0129 | 3030000000-E | 862 | STEEL BM GUARDRAIL | 13,100 LF | 15.70 | 205,670.00 |
| 0130 | 3105000000-N | 862 | STEEL BM GUARDRAIL TERMINAL SECTIONS | 6 EA | 175.00 | 1,050.00 |
| 0131 | 3150000000-N | 862 | ADDITIONAL GUARDRAIL POSTS | 50 EA | 25.00 | 1,250.00 |
| 0132 | 3210000000-N | 862 | GUARDRAIL ANCHOR UNITS, TYPE CAT-1 | 21 EA | 575.00 | 12,075.00 |
| 0133 | 3215000000-N | 862 | GUARDRAIL ANCHOR UNITS, TYPE III | 4 EA | 1,500.00 | 6,000.00 |
| 0134 | 3270000000-N | SP | GUARDRAIL ANCHOR UNITS, TYPE 350 | 30 EA | 1,875.00 | 56,250.00 |
| 0135 | 3285000000-N | SP | GUARDRAIL ANCHOR UNITS, TYPE M-350 | 2 EA | 1,975.00 | 3,950.00 |
| 0136 | 3317000000-N | 862 | GUARDRAIL ANCHOR UNITS, TYPE B-77 | 14 EA | 1,580.00 | 22,120.00 |
| 0137 | 3360000000-E | 863 | REMOVE EXISTING GUARDRAIL | 563 LF | 1.25 | 703.75 |
| 0138 | 3380000000-E | 862 | TEMPORARY STEEL BM GUARDRAIL | 487.5 LF | 11.00 | 5,362.50 |
| 0139 | 3389100000-N | SP | TEMPORARY GUARDRAIL ANCHOR UNITS, TYPE 350 | 2 EA | 1,300.00 | 2,600.00 |
| 0140 | 3500000000-E | 866 | WOVEN WIRE FENCE, *** FABRIC (48") | 37,000 LF | 2.40 | 88,800.00 |
| 0141 | 3509000000-E | 866 | 4" TIMBER FENCE POSTS, 7'-6" LONG | 2,289 EA | 16.00 | 36,624.00 |
| 0142 | 3515000000-E | 866 | 5" TIMBER FENCE POSTS, 8'-0" LONG | 646 EA | 34.00 | 21,964.00 |
| 0143 | 3536000000-E | 866 | CHAIN LINK FENCE, 48" FABRIC | 450 LF | 8.00 | 3,600.00 |

| Line # | ItemNumber | Sec # | Description | Quantity Unit | Unit Bid Price | Amount Bid |
|--------|--------------|-------|---|---------------|----------------|------------|
| 0144 | 3542000000-E | 866 | METAL LINE POSTS FOR 48" CHAIN LINK FENCE | 38 EA | 30.00 | 1,140.00 |
| 0145 | 3548000000-E | 866 | METAL TERMINAL POSTS FOR 48" CHAIN LINK FENCE | 9 EA | 60.00 | 540.00 |
| 0146 | 3557000000-E | 866 | ADDITIONAL BARBED WIRE | 200 LF | 0.25 | 50.00 |
| 0147 | 3564000000-E | 866 | SINGLE GATES, *** HIGH, *** WIDE, *** OPENING (48", 12', 12') | 2 EA | 500.00 | 1,000.00 |
| 0148 | 3564000000-E | 866 | SINGLE GATES, *** HIGH, *** WIDE, *** OPENING (48", 20', 20') | 2 EA | 2,000.00 | 4,000.00 |
| 0149 | 3628000000-E | 876 | RIP RAP, CLASS I | 890 TON | 55.00 | 48,950.00 |
| 0150 | 3635000000-E | 876 | RIP RAP, CLASS II | 25 TON | 65.00 | 1,625.00 |
| 0151 | 3649000000-E | 876 | RIP RAP, CLASS B | 2,430 TON | 50.00 | 121,500.00 |
| 0152 | 3656000000-E | 876 | GEOTEXTILE FOR DRAINAGE | 12,350 SY | 3.01 | 37,173.50 |
| 0153 | 3659000000-N | SP | PREFORMED SCOUR HOLES WITH LEVEL SPREADER APRON | 2 EA | 1,100.00 | 2,200.00 |
| 0154 | 4054000000-E | 902 | PLAIN CONCRETE SIGN FOUNDATIONS | 1 CY | 835.00 | 835.00 |
| 0155 | 4057000000-E | SP | OVERHEAD FOOTING | 73 CY | 1,110.00 | 81,030.00 |
| 0156 | 4060000000-E | 903 | SUPPORTS, BREAKAWAY STEEL BEAM | 1,294 LB | 6.40 | 8,281.60 |
| 0157 | 4072000000-E | 903 | SUPPORTS, 3-LB STEEL U-CHANNEL | 2,753 LF | 5.15 | 14,177.95 |
| 0158 | 4082100000-N | SP | SUPPORTS, OVERHEAD SIGN STRUCTURE AT STA ***** (16+50 -RPC-) | Lump Sum LS | 53,410.00 | 53,410.00 |
| 0159 | 4082100000-N | SP | SUPPORTS, OVERHEAD SIGN STRUCTURE AT STA ***** (21+15 -L-) | Lump Sum LS | 56,835.00 | 56,835.00 |
| 0160 | 4082100000-N | SP | SUPPORTS, OVERHEAD SIGN STRUCTURE AT STA ***** (25+44 -L-) | Lump Sum LS | 22,190.00 | 22,190.00 |

Contract Item Sheets For C203844

| Line # | ItemNumber | Sec # | Description | Quantity Unit | Unit Bid Price | Amount Bid |
|--------|--------------|-------|---|----------------|----------------|------------|
| 0161 | 4082100000-N | SP | SUPPORTS, OVERHEAD SIGN STRUCTURE AT STA ***** (28+17 -L-) | Lump Sum LS | 22,705.00 | 22,705.00 |
| 0162 | 4082100000-N | SP | SUPPORTS, OVERHEAD SIGN STRUCTURE AT STA ***** (32+38 -L-) | Lump Sum LS | 46,170.00 | 46,170.00 |
| 0163 | 4082100000-N | SP | SUPPORTS, OVERHEAD SIGN STRUCTURE AT STA ***** (46+00 -L-) | Lump Sum LS | 21,780.00 | 21,780.00 |
| 0164 | 4096000000-N | 904 | SIGN ERECTION, TYPE D | 4 EA | 115.00 | 460.00 |
| 0165 | 4102000000-N | 904 | SIGN ERECTION, TYPE E | 107 EA | 55.00 | 5,885.00 |
| 0166 | 4108000000-N | 904 | SIGN ERECTION, TYPE F | 42 EA | 170.00 | 7,140.00 |
| 0167 | 4110000000-N | 904 | SIGN ERECTION, TYPE *** (GROUND MOUNTED) (A) | 2 EA | 510.00 | 1,020.00 |
| 0168 | 4116100000-N | 904 | SIGN ERECTION, RELOCATE, TYPE **** (GROUND MOUNTED) (A) | 3 EA | 680.00 | 2,040.00 |
| 0169 | 4138000000-N | 907 | DISPOSAL OF SUPPORT, STEEL BEAM | 3 EA | 560.00 | 1,680.00 |
| 0170 | 4152000000-N | 907 | DISPOSAL OF SIGN SYSTEM, STEEL BEAM | 2 EA | 845.00 | 1,690.00 |
| 0171 | 4155000000-N | 907 | DISPOSAL OF SIGN SYSTEM, U- CHANNEL | 45 EA | 85.00 | 3,825.00 |
| 0172 | 4400000000-E | 1110 | WORK ZONE SIGNS (STATIONARY) | 2,376 SF | 6.00 | 14,256.00 |
| 0173 | 4405000000-E | 1110 | WORK ZONE SIGNS (PORTABLE) | 429 SF | 14.00 | 6,006.00 |
| 0174 | 4410000000-E | 1110 | WORK ZONE SIGNS (BARRICADE MOUNTED) | 474 SF | 7.00 | 3,318.00 |
| 0175 | 4415000000-N | 1115 | FLASHING ARROW BOARD | 4 EA | 4,000.00 | 16,000.00 |
| 0176 | 4420000000-N | 1120 | PORTABLE CHANGEABLE MESSAGE SIGN | 6 EA | 14,000.00 | 84,000.00 |
| 0177 | 4422000000-N | 1120 | PORTABLE CHANGEABLE MESSAGE SIGN (SHORT TERM) | 84 DAY | 260.00 | 21,840.00 |

| Line # | ItemNumber | Sec # | Description | Quantity Unit | Unit Bid Price | Amount Bid |
|--------|--------------|-------|--|---------------|----------------|------------|
| 0178 | 4430000000-N | 1130 | DRUMS | 1,050 EA | 45.00 | 47,250.00 |
| 0179 | 4435000000-N | 1135 | CONES | 70 EA | 25.00 | 1,750.00 |
| 0180 | 4445000000-E | 1145 | BARRICADES (TYPE III) | 512 LF | 21.00 | 10,752.00 |
| 0181 | 4450000000-N | 1150 | FLAGGER | 80 HR | 40.00 | 3,200.00 |
| 0182 | 4455000000-N | 1150 | FLAGGER | 240 DAY | 360.00 | 86,400.00 |
| 0183 | 4465000000-N | 1160 | TEMPORARY CRASH CUSHIONS | 10 EA | 5,000.00 | 50,000.00 |
| 0184 | 4470000000-N | 1160 | RESET TEMPORARY CRASH CUSHION | 6 EA | 1,500.00 | 9,000.00 |
| 0185 | 4480000000-N | 1165 | TMA | 2 EA | 18,000.00 | 36,000.00 |
| 0186 | 4485000000-E | 1170 | PORTABLE CONCRETE BARRIER | 4,200 LF | 17.65 | 74,130.00 |
| 0187 | 4490000000-E | 1170 | PORTABLE CONCRETE BARRIER (ANCHORED) | 200 LF | 29.25 | 5,850.00 |
| 0188 | 4500000000-E | 1170 | RESET PORTABLE CONCRETE BAR- RIER | 1,800 LF | 3.75 | 6,750.00 |
| 0189 | 4520000000-N | 1266 | TUBULAR MARKERS (FIXED) | 13 EA | 100.00 | 1,300.00 |
| 0190 | 4590000000-E | SP | GENERIC TRAFFIC CONTROL ITEM WORK ZONE "PERFORMANCE" PAVEMENT MARKING LINES (6") | 7,800 LF | 1.25 | 9,750.00 |
| 0191 | 4595000000-E | SP | GENERIC TRAFFIC CONTROL ITEM WORK ZONE TRAFFIC "PATTERN MASKING" | 437,000 SF | 0.23 | 100,510.00 |
| 0192 | 4600000000-N | SP | GENERIC TRAFFIC CONTROL ITEM SEQUENTIAL FLASHING WARNING LIGHTS | 24 EA | 300.00 | 7,200.00 |
| 0193 | 4650000000-N | 1251 | TEMPORARY RAISED PAVEMENT MARKERS | 831 EA | 8.00 | 6,648.00 |
| 0194 | 4685000000-E | 1205 | THERMOPLASTIC PAVEMENT MARKING LINES (4", 90 MILS) | 83,000 LF | 0.79 | 65,570.00 |
| 0195 | 4686000000-E | 1205 | THERMOPLASTIC PAVEMENT MARKING LINES (4", 120 MILS) | 67,850 LF | 0.89 | 60,386.50 |

Contract Item Sheets For C203844

| Line # | ItemNumber | Sec # | Description | Quantity Unit | Unit Bid Price | Amount Bid |
|--------|--------------|-------|--|---------------|----------------|------------|
| 0196 | 4688000000-E | 1205 | THERMOPLASTIC PAVEMENT MARKING LINES (6", 90 MILS) | 5,000 LF | 0.99 | 4,950.00 |
| 0197 | 4690000000-E | 1205 | THERMOPLASTIC PAVEMENT MARKING LINES (6", 120 MILS) | 2,150 LF | 1.19 | 2,558.50 |
| 0198 | 4695000000-E | 1205 | THERMOPLASTIC PAVEMENT MARKING LINES (8", 90 MILS) | 7,500 LF | 2.00 | 15,000.00 |
| 0199 | 4697000000-E | 1205 | THERMOPLASTIC PAVEMENT MARKING LINES (8", 120 MILS) | 4,000 LF | 2.00 | 8,000.00 |
| 0200 | 4700000000-E | 1205 | THERMOPLASTIC PAVEMENT MARKING LINES (12", 90 MILS) | 17,000 LF | 3.50 | 59,500.00 |
| 0201 | 4710000000-E | 1205 | THERMOPLASTIC PAVEMENT MARKING LINES (24", 120 MILS) | 2,600 LF | 12.00 | 31,200.00 |
| 0202 | 4721000000-E | 1205 | THERMOPLASTIC PAVEMENT MARKING CHARACTER (120 MILS) | 32 EA | 90.00 | 2,880.00 |
| 0203 | 4725000000-E | 1205 | THERMOPLASTIC PAVEMENT MARKING SYMBOL (90 MILS) | 300 EA | 175.00 | 52,500.00 |
| 0204 | 4770000000-E | 1205 | COLD APPLIED PLASTIC PAVEMENT MARKING LINES, TYPE ** (4") (II) | 3,501 LF | 1.90 | 6,651.90 |
| 0205 | 4770000000-E | 1205 | COLD APPLIED PLASTIC PAVEMENT MARKING LINES, TYPE ** (4") (IV) | 1,175 LF | 1.90 | 2,232.50 |
| 0206 | 4780000000-E | 1205 | COLD APPLIED PLASTIC PAVEMENT MARKING LINES, TYPE ** (8") (II) | 30 LF | 3.80 | 114.00 |
| 0207 | 4805000000-N | 1205 | COLD APPLIED PLASTIC PAVEMENT MARKING SYMBOL, TYPE ** (II) | 9 EA | 250.00 | 2,250.00 |
| 0208 | 4810000000-E | 1205 | PAINT PAVEMENT MARKING LINES (4") | 601,688 LF | 0.12 | 72,202.56 |
| 0209 | 4815000000-E | 1205 | PAINT PAVEMENT MARKING LINES (6") | 13,200 LF | 0.20 | 2,640.00 |
| 0210 | 4820000000-E | 1205 | PAINT PAVEMENT MARKING LINES (8") | 9,510 LF | 1.00 | 9,510.00 |

| Line # | ItemNumber | Sec # | Description | Quantity Unit | Unit Bid Price | Amount Bid |
|--------|--------------|-------|--|---------------|----------------|------------|
| 0211 | 4825000000-E | 1205 | PAINT PAVEMENT MARKING LINES (12") | 9,400 LF | 1.00 | 9,400.00 |
| 0212 | 4835000000-E | 1205 | PAINT PAVEMENT MARKING LINES (24") | 7,980 LF | 3.00 | 23,940.00 |
| 0213 | 4840000000-N | 1205 | PAINT PAVEMENT MARKING CHARACTER | 20 EA | 35.00 | 700.00 |
| 0214 | 4845000000-N | 1205 | PAINT PAVEMENT MARKING SYMBOL | 457 EA | 35.00 | 15,995.00 |
| 0215 | 4850000000-E | 1205 | REMOVAL OF PAVEMENT MARKING LINES (4") | 21,000 LF | 0.75 | 15,750.00 |
| 0216 | 4855000000-E | 1205 | REMOVAL OF PAVEMENT MARKING LINES (6") | 6,975 LF | 0.75 | 5,231.25 |
| 0217 | 4860000000-E | 1205 | REMOVAL OF PAVEMENT MARKING LINES (8") | 900 LF | 1.00 | 900.00 |
| 0218 | 4870000000-E | 1205 | REMOVAL OF PAVEMENT MARKING LINES (24") | 200 LF | 3.00 | 600.00 |
| 0219 | 4875000000-N | 1205 | REMOVAL OF PAVEMENT MARKING SYMBOLS & CHARACTERS | 23 EA | 30.00 | 690.00 |
| 0220 | 4900000000-N | 1251 | PERMANENT RAISED PAVEMENT MARKERS | 1,390 EA | 8.00 | 11,120.00 |
| 0221 | 4905000000-N | 1253 | SNOWPLOWABLE PAVEMENT MARKERS | 84 EA | 75.00 | 6,300.00 |
| 0222 | 5255000000-N | 1413 | PORTABLE LIGHTING | Lump Sum LS | 50,000.00 | 50,000.00 |
| 0223 | 5546000000-E | 1515 | 8" VALVE | 5 EA | 650.00 | 3,250.00 |
| 0224 | 5589200000-E | 1515 | 2" AIR RELEASE VALVE | 2 EA | 3,500.00 | 7,000.00 |
| 0225 | 5709400000-E | 1520 | 8" FORCE MAIN SEWER | 2,799 LF | 50.00 | 139,950.00 |
| 0226 | 5769000000-E | SP | DUCTILE IRON SEWER PIPE FITTINGS | 440 LB | 1.60 | 704.00 |
| 0227 | 5801000000-E | 1530 | ABANDON 8" UTILITY PIPE | 2,745 LF | 7.00 | 19,215.00 |
| 0228 | 5871500000-E | 1550 | TRENCHLESS INSTALLATION OF 8" IN SOIL | 245 LF | 110.00 | 26,950.00 |

| Line # | ItemNumber | Sec # | Description | Quantity Unit | Unit Bid Price | Amount Bid |
|--------|--------------|-------|---|---------------|----------------|------------|
| 0229 | 5871510000-E | 1550 | TRENCHLESS INSTALLATION OF 8" NOT IN SOIL | 245 LF | 360.00 | 88,200.00 |
| 0230 | 6000000000-E | 1605 | TEMPORARY SILT FENCE | 120,000 LF | 1.90 | 228,000.00 |
| 0231 | 6006000000-E | 1610 | STONE FOR EROSION CONTROL, CLASS A | 3,080 TON | 55.00 | 169,400.00 |
| 0232 | 6009000000-E | 1610 | STONE FOR EROSION CONTROL, CLASS B | 11,500 TON | 58.00 | 667,000.00 |
| 0233 | 6012000000-E | 1610 | SEDIMENT CONTROL STONE | 27,500 TON | 20.00 | 550,000.00 |
| 0234 | 6015000000-E | 1615 | TEMPORARY MULCHING | 148 ACR | 1,200.00 | 177,600.00 |
| 0235 | 6018000000-E | 1620 | SEED FOR TEMPORARY SEEDING | 7,200 LB | 1.50 | 10,800.00 |
| 0236 | 6021000000-E | 1620 | FERTILIZER FOR TEMPORARY SEEDING | 38 TON | 990.00 | 37,620.00 |
| 0237 | 6024000000-E | 1622 | TEMPORARY SLOPE DRAINS | 6,200 LF | 40.00 | 248,000.00 |
| 0238 | 6029000000-E | SP | SAFETY FENCE | 4,400 LF | 1.90 | 8,360.00 |
| 0239 | 6030000000-E | 1630 | SILT EXCAVATION | 110,000 CY | 0.01 | 1,100.00 |
| 0240 | 6036000000-E | 1631 | MATTING FOR EROSION CONTROL | 140,000 SY | 1.50 | 210,000.00 |
| 0241 | 6037000000-E | SP | COIR FIBER MAT | 565 SY | 8.00 | 4,520.00 |
| 0242 | 6038000000-E | SP | PERMANENT SOIL REINFORCEMENT MAT | 13,220 SY | 7.75 | 102,455.00 |
| 0243 | 6042000000-E | 1632 | 1/4" HARDWARE CLOTH | 16,620 LF | 3.00 | 49,860.00 |
| 0244 | 6045000000-E | SP | *** TEMPORARY PIPE (18") | 160 LF | 35.00 | 5,600.00 |
| 0245 | 6046000000-E | 1636 | TEMPORARY PIPE FOR STREAM CROSSING | 300 LF | 70.00 | 21,000.00 |
| 0246 | 6048000000-E | SP | FLOATING TURBIDITY CURTAIN | 520 SY | 3.00 | 1,560.00 |
| 0247 | 6069000000-E | 1638 | STILLING BASINS | 750 CY | 9.00 | 6,750.00 |

| Line # | ItemNumber | Sec # | Description | Quantity Unit | Unit Bid Price | Amount Bid |
|--------|--------------|-------|-------------------------------|---------------|----------------|------------|
| 0248 | 6070000000-N | 1639 | SPECIAL STILLING BASINS | 4 EA | 1,000.00 | 4,000.00 |
| 0249 | 6071012000-E | SP | COIR FIBER WATTLE | 10,800 LF | 7.00 | 75,600.00 |
| 0250 | 6071020000-E | SP | POLYACRYLAMIDE (PAM) | 8,100 LB | 4.00 | 32,400.00 |
| 0251 | 6071030000-E | 1640 | COIR FIBER BAFFLE | 9,825 LF | 3.90 | 38,317.50 |
| 0252 | 6071050000-E | SP | *** SKIMMER (1-1/2") | 33 EA | 2,200.00 | 72,600.00 |
| 0253 | 6071050000-E | SP | *** SKIMMER (2") | 11 EA | 2,400.00 | 26,400.00 |
| 0254 | 6071050000-E | SP | *** SKIMMER (2-1/2") | 2 EA | 2,600.00 | 5,200.00 |
| 0255 | 6071050000-E | SP | *** SKIMMER (3") | 1 EA | 3,000.00 | 3,000.00 |
| 0256 | 6084000000-E | 1660 | SEEDING & MULCHING | 102 ACR | 2,185.00 | 222,870.00 |
| 0257 | 6087000000-E | 1660 | MOWING | 90 ACR | 118.00 | 10,620.00 |
| 0258 | 6090000000-E | 1661 | SEED FOR REPAIR SEEDING | 1,500 LB | 9.50 | 14,250.00 |
| 0259 | 6093000000-E | 1661 | FERTILIZER FOR REPAIR SEEDING | 3.75 TON | 2,350.00 | 8,812.50 |
| 0260 | 6096000000-E | 1662 | SEED FOR SUPPLEMENTAL SEEDING | 2,325 LB | 2.00 | 4,650.00 |
| 0261 | 6108000000-E | 1665 | FERTILIZER TOPDRESSING | 70 TON | 970.00 | 67,900.00 |
| 0262 | 6111000000-E | SP | IMPERVIOUS DIKE | 400 LF | 185.00 | 74,000.00 |
| 0263 | 6114500000-N | 1667 | SPECIALIZED HAND MOWING | 500 MHR | 24.50 | 12,250.00 |
| 0264 | 6117000000-N | SP | RESPONSE FOR EROSION CONTROL | 100 EA | 200.00 | 20,000.00 |
| 0265 | 6120000000-E | SP | CULVERT DIVERSION CHANNEL | 1,350 CY | 21.00 | 28,350.00 |
| 0266 | 6123000000-E | 1670 | REFORESTATION | 5 ACR | 750.00 | 3,750.00 |
| 0267 | 6126000000-E | SP | STREAMBANK REFORESTATION | 0.32 ACR | 5,000.00 | 1,600.00 |

Contract Item Sheets For C203844

| Line # | ItemNumber | Sec # | Description | Quantity Unit | Unit Bid Price | Amount Bid |
|--------|--------------|-------|--|---------------|----------------|------------|
| 0268 | 6132000000-N | SP | GENERIC EROSION CONTROL ITEM CONCRETE WASHOUT STRUCTURE | 16 EA | 490.00 | 7,840.00 |
| 0269 | 7048500000-E | 1705 | PEDESTRIAN SIGNAL HEAD (16", 1 SECTION W/COUNTDOWN) | 34 EA | 870.00 | 29,580.00 |
| 0270 | 7060000000-E | 1705 | SIGNAL CABLE | 23,925 LF | 2.40 | 57,420.00 |
| 0271 | 7120000000-E | 1705 | VEHICLE SIGNAL HEAD (12", 3 SECTION) | 123 EA | 650.00 | 79,950.00 |
| 0272 | 7132000000-E | 1705 | VEHICLE SIGNAL HEAD (12", 4 SECTION) | 10 EA | 0.00 | 0.00 |
| 0273 | 7144000000-E | 1705 | VEHICLE SIGNAL HEAD (12", 5 SECTION) | 11 EA | 1,125.00 | 12,375.00 |
| 0274 | 7252000000-E | 1710 | MESSENGER CABLE (1/4") | 10,455 LF | 1.50 | 15,682.50 |
| 0275 | 7279000000-E | 1715 | TRACER WIRE | 3,800 LF | 0.50 | 1,900.00 |
| 0276 | 7300000000-E | 1715 | UNPAVED TRENCHING (***** (1, 2")) | 8,910 LF | 6.55 | 58,360.50 |
| 0277 | 7300100000-E | 1715 | UNPAVED TRENCHING FOR TEMP- ORARY LEAD-IN | 1,965 LF | 3.05 | 5,993.25 |
| 0278 | 7301000000-E | 1715 | DIRECTIONAL DRILL (***** (1, 2")) | 425 LF | 15.25 | 6,481.25 |
| 0279 | 7301000000-E | 1715 | DIRECTIONAL DRILL (***** (2, 2")) | 175 LF | 16.50 | 2,887.50 |
| 0280 | 7324000000-N | 1716 | JUNCTION BOX (STANDARD SIZE) | 92 EA | 280.00 | 25,760.00 |
| 0281 | 7348000000-N | 1716 | JUNCTION BOX (OVER-SIZED, HEA- VY DUTY) | 21 EA | 505.00 | 10,605.00 |
| 0282 | 7360000000-N | 1720 | WOOD POLE | 15 EA | 915.00 | 13,725.00 |
| 0283 | 7372000000-N | 1721 | GUY ASSEMBLY | 36 EA | 290.00 | 10,440.00 |
| 0284 | 7408000000-E | 1722 | 1" RISER WITH WEATHERHEAD | 4 EA | 640.00 | 2,560.00 |
| 0285 | 7420000000-E | 1722 | 2" RISER WITH WEATHERHEAD | 12 EA | 425.00 | 5,100.00 |

Contract Item Sheets For C203844

| Line # | ItemNumber | Sec # | Description | Quantity Unit | Unit Bid Price | Amount Bid |
|--------|--------------|-------|---|---------------|----------------|------------|
| 0286 | 7432000000-E | 1722 | 2" RISER WITH HEAT SHRINK TUBING | 10 EA | 480.00 | 4,800.00 |
| 0287 | 7444000000-E | 1725 | INDUCTIVE LOOP SAWCUT | 15,125 LF | 6.50 | 98,312.50 |
| 0288 | 7456000000-E | 1726 | LEAD-IN CABLE (***** (14-2) | 43,725 LF | 1.70 | 74,332.50 |
| 0289 | 7481000000-N | SP | SITE SURVEY | 2 EA | 460.00 | 920.00 |
| 0290 | 7481220000-N | SP | CAMERA WITH INTERNAL LOOP EMU- LATOR PROCESSING UNIT | 4 EA | 4,080.00 | 16,320.00 |
| 0291 | 7481280000-N | SP | RELOCATE CAMERA SENSOR UNIT | 2 EA | 75.00 | 150.00 |
| 0292 | 7516000000-E | 1730 | COMMUNICATIONS CABLE (**FIBER) (12) | 3,500 LF | 1.60 | 5,600.00 |
| 0293 | 7516000000-E | 1730 | COMMUNICATIONS CABLE (**FIBER) (24) | 5,800 LF | 1.70 | 9,860.00 |
| 0294 | 7540000000-N | 1731 | SPLICE ENCLOSURE | 5 EA | 1,830.00 | 9,150.00 |
| 0295 | 7552000000-N | 1731 | INTERCONNECT CENTER | 7 EA | 1,595.00 | 11,165.00 |
| 0296 | 7564000000-N | 1732 | FIBER-OPTIC TRANSCEIVER, DROP & REPEAT | 7 EA | 2,010.00 | 14,070.00 |
| 0297 | 7566000000-N | 1733 | DELINEATOR MARKER | 13 EA | 145.00 | 1,885.00 |
| 0298 | 7575142000-N | 1736 | 900MHZ RADIO | 3 EA | 3,435.00 | 10,305.00 |
| 0299 | 7575160000-E | 1734 | REMOVE EXISTING COMMUNICATIONS CABLE | 1,200 LF | 1.20 | 1,440.00 |
| 0300 | 7576000000-N | SP | METAL STRAIN SIGNAL POLE | 32 EA | 6,680.00 | 213,760.00 |
| 0301 | 7588000000-N | SP | METAL POLE WITH SINGLE MAST ARM | 2 EA | 7,875.00 | 15,750.00 |
| 0302 | 7590000000-N | SP | METAL POLE WITH DUAL MAST ARM | 2 EA | 16,750.00 | 33,500.00 |
| 0303 | 7613000000-N | SP | SOIL TEST | 36 EA | 855.00 | 30,780.00 |
| 0304 | 7614100000-E | SP | DRILLED PIER FOUNDATION | 216 CY | 805.00 | 173,880.00 |

Contract Item Sheets For C203844

| Line # | ItemNumber | Sec # | Description | Quantity Unit | Unit Bid Price | Amount Bid |
|--------|--------------|-------|--|---------------|----------------|------------|
| 0305 | 7631000000-N | SP | MAST ARM WITH METAL POLE DE-SIGN | 4 EA | 60.00 | 240.00 |
| 0306 | 7636000000-N | 1745 | SIGN FOR SIGNALS | 38 EA | 195.00 | 7,410.00 |
| 0307 | 7642100000-N | 1743 | TYPE I POST WITH FOUNDATION | 2 EA | 1,130.00 | 2,260.00 |
| 0308 | 7642200000-N | 1743 | TYPE II PEDESTAL WITH FOUNDATION | 28 EA | 1,575.00 | 44,100.00 |
| 0309 | 7684000000-N | 1750 | SIGNAL CABINET FOUNDATION | 10 EA | 1,000.00 | 10,000.00 |
| 0310 | 7756000000-N | 1751 | CONTROLLER WITH CABINET (TYPE 2070L, BASE MOUNTED) | 10 EA | 12,000.00 | 120,000.00 |
| 0311 | 7768000000-N | 1751 | CONTROLLER WITH CABINET (TYPE 2070L, POLE MOUNTED) | 2 EA | 11,350.00 | 22,700.00 |
| 0312 | 7780000000-N | 1751 | DETECTOR CARD (TYPE 2070L) | 69 EA | 135.00 | 9,315.00 |
| 0313 | 7901000000-N | 1753 | CABINET BASE EXTENDER | 10 EA | 335.00 | 3,350.00 |
| 0314 | 7980000000-N | SP | GENERIC SIGNAL ITEM MICROWAVE VEHICLE DETECTOR - SINGLE ZONE | 2 EA | 1,125.00 | 2,250.00 |

Contract Item Sheets For C203844

| Line # | ItemNumber | Sec # | Description | Quantity Unit | Unit Bid Price | Amount Bid |
|--------|--------------|-------|--|----------------|----------------|------------|
| 0315 | 8035000000-N | 402 | REMOVAL OF EXISTING STRUCTURE AT STATION ***** (19+77.00-Y10-) | Lump Sum LS | 1,538.45 | 1,538.45 |
| 0316 | 8126000000-N | 414 | CULVERT EXCAVATION, STA ***** (179+55.00-L-) | Lump Sum LS | 1,185.73 | 1,185.73 |
| 0317 | 8126000000-N | 414 | CULVERT EXCAVATION, STA ***** (19+77.00-Y10-) | Lump Sum LS | 2,973.13 | 2,973.13 |
| 0318 | 8126000000-N | 414 | CULVERT EXCAVATION, STA ***** (96+88.00 -L-) | Lump Sum LS | 12,850.76 | 12,850.76 |
| 0319 | 8133000000-E | 414 | FOUNDATION CONDITIONING MATER- IAL, BOX CULVERT | 888 TON | 35.00 | 31,080.00 |
| 0320 | 8196000000-E | 420 | CLASS A CONCRETE (CULVERT) | 1,200.6 CY | 440.18 | 528,480.11 |
| 0321 | 8245000000-E | 425 | REINFORCING STEEL (CULVERT) | 142,445 LB | 1.00 | 142,445.00 |

Contract Item Sheets For C203844

| Line # | ItemNumber | Sec # | Description | Quantity Unit | Unit Bid Price | Amount Bid |
|--------|--------------|-------|--------------------------------------|---------------|----------------|------------|
| 0322 | 8801000000-E | SP | MSE RETAINING WALL NO **** (1) | 3,449 SF | 130.00 | 448,370.00 |
| 0323 | 8801000000-E | SP | MSE RETAINING WALL NO **** (2) | 4,617 SF | 135.00 | 623,295.00 |
| 0324 | 8802030000-E | SP | SEGMENTAL GRAVITY RETAINING WALLS | 263 SF | 30.00 | 7,890.00 |

Contract Item Sheets For C203844

| Line # | ItemNumber | Sec # | Description | Quantity Unit | Unit Bid Price | Amount Bid |
|--------|--------------|-------|--|----------------|----------------|--------------|
| 0325 | 8091000000-N | 410 | FOUNDATION EXCAVATION FOR BENT ** AT STATION ***** (1,146+61.35-L-NBL) | Lump Sum LS | 1,000.00 | 1,000.00 |
| 0326 | 8091000000-N | 410 | FOUNDATION EXCAVATION FOR BENT ** AT STATION ***** (1,146+61.35-L-SBL) | Lump Sum LS | 1,000.00 | 1,000.00 |
| 0327 | 8091000000-N | 410 | FOUNDATION EXCAVATION FOR BENT ** AT STATION ***** (2,146+61.35-L-NBL) | Lump Sum LS | 1,000.00 | 1,000.00 |
| 0328 | 8091000000-N | 410 | FOUNDATION EXCAVATION FOR BENT ** AT STATION ***** (2,146+61.35-L-SBL) | Lump Sum LS | 1,000.00 | 1,000.00 |
| 0329 | 8091000000-N | 410 | FOUNDATION EXCAVATION FOR BENT ** AT STATION ***** (3,146+61.35-L-NBL) | Lump Sum LS | 1,000.00 | 1,000.00 |
| 0330 | 8091000000-N | 410 | FOUNDATION EXCAVATION FOR BENT ** AT STATION ***** (3,146+61.35-L-SBL) | Lump Sum LS | 1,000.00 | 1,000.00 |
| 0331 | 8105560000-E | 411 | 4'-0" DIA DRILLED PIERS IN SOIL | 70.3 LF | 687.36 | 48,321.41 |
| 0332 | 8105660000-E | 411 | 4'-0" DIA DRILLED PIERS NOT IN SOIL | 31 LF | 2,323.91 | 72,041.21 |
| 0333 | 8112730000-N | 450 | PDA TESTING | 1 EA | 3,400.00 | 3,400.00 |
| 0334 | 8113000000-N | 411 | SID INSPECTIONS | 3 EA | 500.00 | 1,500.00 |
| 0335 | 8114000000-N | 411 | SPT TESTING | 3 EA | 2,000.00 | 6,000.00 |
| 0336 | 8115000000-N | 411 | CSL TESTING | 1 EA | 3,000.00 | 3,000.00 |
| 0337 | 8147000000-E | 420 | REINFORCED CONCRETE DECK SLAB | 46,347 SF | 37.32 | 1,729,670.04 |
| 0338 | 8161000000-E | 420 | GROOVING BRIDGE FLOORS | 42,545 SF | 0.61 | 25,952.45 |
| 0339 | 8182000000-E | 420 | CLASS A CONCRETE (BRIDGE) | 871.6 CY | 1,159.00 | 1,010,184.40 |
| 0340 | 8210000000-N | 422 | BRIDGE APPROACH SLABS, STATION ***** (146+61.35-L-NBL) | Lump Sum LS | 65,000.00 | 65,000.00 |

Contract Item Sheets For C203844

| Line # | ItemNumber | Sec # | Description | Quantity Unit | Unit Bid Price | Amount Bid |
|--------|--------------|-------|--|----------------|----------------|--------------|
| 0341 | 8210000000-N | 422 | BRIDGE APPROACH SLABS, STATION ***** (146+61.35-L-SBL) | Lump Sum LS | 65,000.00 | 65,000.00 |
| 0342 | 8210000000-N | 422 | BRIDGE APPROACH SLABS, STATION ***** (26+54.73-NBL-) | Lump Sum LS | 130,000.00 | 130,000.00 |
| 0343 | 8217000000-E | 425 | REINFORCING STEEL (BRIDGE) | 143,844 LB | 1.00 | 143,844.00 |
| 0344 | 8238000000-E | 425 | SPIRAL COLUMN REINFORCING STEEL (BRIDGE) | 14,778 LB | 2.00 | 29,556.00 |
| 0345 | 8277000000-E | 430 | MODIFIED 72" PRESTRESSED CONC GIRDERS | 3,901.13 LF | 400.00 | 1,560,452.00 |
| 0346 | 8280000000-E | 440 | APPROX LBS STRUCTURAL STEEL | 446,250 LS | 1,600,000.00 | 1,600,000.00 |
| 0347 | 8328200000-E | SP | PILE DRIVING EQUIPMENT SETUP FOR *** STEEL PILES (HP 12 X 53) | 132 EA | 345.00 | 45,540.00 |
| 0348 | 8364000000-E | 450 | HP12X53 STEEL PILES | 8,200 LF | 55.00 | 451,000.00 |
| 0349 | 8475000000-E | 460 | TWO BAR METAL RAIL | 472.38 LF | 36.00 | 17,005.68 |
| 0350 | 8503000000-E | 460 | CONCRETE BARRIER RAIL | 2,050.4 LF | 90.00 | 184,536.00 |
| 0351 | 8517000000-E | 460 | 1'-***"X ***** CONCRETE PARA- PET (1'-2" X 2'-6") | 243.69 LF | 80.00 | 19,495.20 |
| 0352 | 8517000000-E | 460 | 1'-***"X ***** CONCRETE PARA- PET (1'-2" X 3'-0 1/2") | 243.69 LF | 80.00 | 19,495.20 |
| 0353 | 8531000000-E | 462 | 4" SLOPE PROTECTION | 905 SY | 150.00 | 135,750.00 |
| 0354 | 8657000000-N | 430 | ELASTOMERIC BEARINGS | Lump Sum LS | 75,000.00 | 75,000.00 |
| 0355 | 8706000000-N | SP | EXPANSION JOINT SEALS | Lump Sum LS | 250,000.00 | 250,000.00 |
| 0356 | 8727000000-N | SP | ELECTRICAL CONDUIT SYSTEM FOR SIGNALS AT STA***** (146+61.35-L- NBL) | Lump Sum LS | 65,000.00 | 65,000.00 |

Contract Item Sheets For C203844

| Line # | ItemNumber | Sec # | Description | Quantity Unit | Unit Bid Price | Amount Bid |
|--------|--------------|-------|---|---------------|----------------|------------|
| 0357 | 8867000000-E | SP | GENERIC STRUCTURE ITEM TWO BAR METAL RAIL RETROFIT | 426.69 LF | 185.00 | 78,937.65 |

TOTAL AMOUNT OF BID FOR ENTIRE PROJECT

\$45,389,069.36

1459/Jun05/Q4808796.197000002/D1528964654000/E357

Contract No. C203844
County Alamance

Rev. 5-19-11

**EXECUTION OF CONTRACT
NON-COLLUSION AFFIDAVIT, DEBARMENT CERTIFICATION AND GIFT BAN CERTIFICATION**

CORPORATION

The Contractor being duly sworn, solemnly swears (or affirms) that neither he, nor any official, agent or employee has entered into any agreement, participated in any collusion, or otherwise taken any action which is in restraint of free competitive bidding in connection with this Contract, that the Contractor has not been convicted of violating N.C.G.S. § 133-24 within the last three years, and that the Contractor intends to do the work with its own bonafide employees or subcontractors and did not bid for the benefit of another contractor.

By submitting this Execution of Contract, Non-Collusion Affidavit and Debarment Certification, the Contractor is certifying his status under penalty of perjury under the laws of the United States in accordance with the Debarment Certification attached, provided that the Debarment Certification also includes any required statements concerning exceptions that are applicable.

N.C.G.S. § 133-32 and Executive Order 24 prohibit the offer to, or acceptance by, any State Employee of any gift from anyone with a contract with the State, or from any person seeking to do business with the State. By execution of any response in this procurement, you attest, for your entire organization and its employees or agents, that you are not aware that any such gift has been offered, accepted, or promised by any employees of your organization.

SIGNATURE OF CONTRACTOR

Thalle Construction Company, Inc.

Full name of Corporation

900 NC 86 North, Hillsborough, NC 27278

Address as Prequalified

Attest

[Signature]
Secretary/Assistant Secretary
Select appropriate title

By

[Signature]
President/Vice President/Assistant Vice President
Select appropriate title

Larry A. Fantozzi

Print or type Signer's name

Stephen E. Kohler

Print or type Signer's name

CORPORATE SEAL

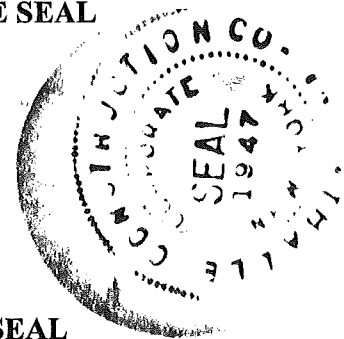

AFFIDAVIT MUST BE NOTARIZED

Subscribed and sworn to before me this the

8 day of June 2017

[Signature]
Signature of Notary Public

NOTARY SEAL

of Orange County

State of North Carolina

My Commission Expires: August 2, 2017

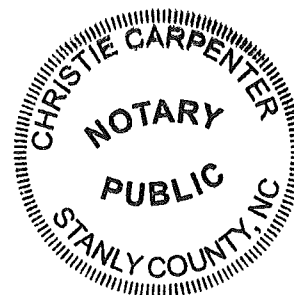

DEBARMENT CERTIFICATION

Conditions for certification:

1. The prequalified bidder shall provide immediate written notice to the Department if at any time the bidder learns that his certification was erroneous when he submitted his debarment certification or explanation filed with the Department, or has become erroneous because of changed circumstances.
2. The terms *covered transaction, debarred, suspended, ineligible, lower tier covered transaction, participant, person, primary covered transaction, principal, proposal, and voluntarily excluded*, as used in this provision, have the meanings set out in the Definitions and Coverage sections of the rules implementing Executive Order 12549. A copy of the Federal Rules requiring this certification and detailing the definitions and coverages may be obtained from the Contract Officer of the Department.
3. The prequalified bidder agrees by submitting this form, that he will not knowingly enter into any lower tier covered transaction with a person who is debarred, suspended, declared ineligible, or voluntarily excluded from participation in NCDOT contracts, unless authorized by the Department.
4. For Federal Aid projects, the prequalified bidder further agrees that by submitting this form he will include the Federal-Aid Provision titled *Required Contract Provisions Federal-Aid Construction Contract (Form FHWA PR 1273)* provided by the Department, without subsequent modification, in all lower tier covered transactions.
5. The prequalified bidder may rely upon a certification of a participant in a lower tier covered transaction that he is not debarred, suspended, ineligible, or voluntarily excluded from the covered transaction, unless he knows that the certification is erroneous. The bidder may decide the method and frequency by which he will determine the eligibility of his subcontractors.
6. Nothing contained in the foregoing shall be construed to require establishment of a system of records in order to render in good faith the certification required by this provision. The knowledge and information of a participant is not required to exceed that which is normally possessed by a prudent person in the ordinary course of business dealings.
7. Except as authorized in paragraph 6 herein, the Department may terminate any contract if the bidder knowingly enters into a lower tier covered transaction with a person who is suspended, debarred, ineligible, or voluntarily excluded from participation in this transaction, in addition to other remedies available by the Federal Government.

Contract No. C203844

Rev. 5-19-11

County Alamance

DEBARMENT CERTIFICATION

The prequalified bidder certifies to the best of his knowledge and belief, that he and his principals:

- a. Are not presently debarred, suspended, proposed for debarment, declared ineligible, or voluntarily excluded from covered transactions by any Federal department or agency;
- b. Have not within a three-year period preceding this proposal been convicted of or had a civil judgment rendered against them for commission of fraud or a criminal offense in connection with obtaining, attempting to obtain, or performing a public (Federal, State or local) transaction or contract under a public transaction; violation of Federal or State antitrust statutes or commission of embezzlement, theft, forgery, bribery, falsification or destruction of records; making false statements; or receiving stolen property;
- c. Are not presently indicted for or otherwise criminally or civilly charged by a governmental entity (Federal, State or local) with commission of any of the offenses enumerated in paragraph b. of this certification; and
- d. Have not within a three-year period preceding this proposal had one or more public transactions (Federal, State or local) terminated for cause or default.
- e. Will submit a revised Debarment Certification immediately if his status changes and will show in his bid proposal an explanation for the change in status.

If the prequalified bidder cannot certify that he is not debarred, he shall provide an explanation with this submittal. An explanation will not necessarily result in denial of participation in a contract.

Failure to submit a non-collusion affidavit and debarment certification will result in the prequalified bidder's bid being considered non-responsive.

Check here if an explanation is attached to this certification.

Contract No. **C203844**

County (ies): **Alamance**

ACCEPTED BY THE
DEPARTMENT OF TRANSPORTATION

DocuSigned by:
Ronald E. Davenport, Jr.
F81B6038A47A442...

Contract Officer

6/15/2017

Date

Execution of Contract and Bonds
Approved as to Form:

DocuSigned by:
Mollie Cozart
46B43E512C354B9...

Attorney General

6/15/2017

Date

Contract No. C203844
County Alamance

Rev 5-17-11

Bond No. 8245-21-10 Federal Insurance Company
Bond No. 015053854 Liberty Mutual Insurance Company

CONTRACT PAYMENT BOND

Date of Payment Bond Execution June 1, 2017

Name of Principal Contractor Thalle Construction Company, Inc.
Federal Insurance Company, 15 Mountain View Road, Warren, NJ 07059
Liberty Mutual Insurance Company, 175 Berkeley Street, Boston, MA 02116

Name of Surety:

Name of Contracting Body: **North Carolina Department of Transportation**
Raleigh, North Carolina

Amount of Bond: \$45,389,069.36

Contract ID No.: C203844

County Name: Alamance

KNOW ALL MEN BY THESE PRESENTS, That we, the PRINCIPAL CONTRACTOR (hereafter, PRINCIPAL) and SURETY above named, are held and firmly bound unto the above named Contracting Body, hereinafter called the Contracting Body, in the penal sum of the amount stated above for the payment of which sum well and truly to be made, we bind ourselves, our heirs, executors, administrators, and successors, jointly and severally, firmly by these presents.

THE CONDITION OF THIS OBLIGATION IS SUCH, that whereas the principal entered into a certain contract with the Contracting Body, numbered as shown above and hereto attached:

NOW THEREFORE, if the principal shall promptly make payment to all persons supplying labor and material in the prosecution of the work provided for in said contract, and any and all duly authorized modifications of said contract that may hereafter be made, notice of which modifications to the surety being hereby waived, then this obligation to be void; otherwise to remain in full force and virtue.

IN WITNESS WHEREOF, the above-bound parties have executed this instrument under their several seals on the date indicated above, the name and corporate seal of each corporate party being hereto affixed and these presents duly signed by its undersigned representative, pursuant to authority of its governing body.

Contract No.
County

C203844
Alamance

Rev 5-17-11

CONTRACT PAYMENT BOND

Federal Insurance Company

Liberty Mutual Insurance Company

Print or type Surety Company Name

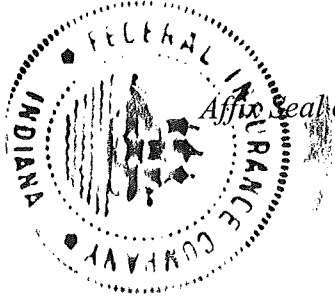

By Krystal L. Stravato, Attorney-In-Fact

Print, stamp or type name of Attorney-in-Fact

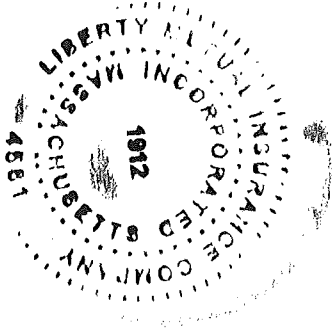

Signature of Attorney-in-Fact

Signature of Witness

Kevin T. Walsh, Jr., Witness

Print or type Signer's name

240 Cedar Knolls Road, Suite 202
Cedar Knolls, NJ 07927

Address of Attorney-in-Fact

Contract No.
County

C203844
Alamance

Rev 5-17-11

CONTRACT PAYMENT BOND
CORPORATION

SIGNATURE OF CONTRACTOR (Principal)

Thalle Construction Company, Inc.

Full name of Corporation

900 NC 86 North, Hillsborough, NC 27278

Address as prequalified

By

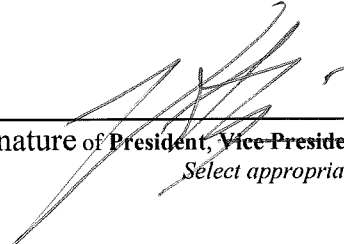
Signature of ~~President, Vice-President, Assistant Vice-President~~
Select appropriate title

Peter K. Tully, Chief Executive Officer

Print or type Signer's name

Affix Corporate Seal



Attest

Signature of ~~Secretary, Assistant Secretary~~
Select appropriate title

Kenneth W. Tully
Print or type Signer's name

Contract No.
County

C203844
Alamance

Rev 5-17-11

CONTRACT PAYMENT BOND

Attach certified copy of Power of Attorney to this sheet

ACKNOWLEDGEMENT OF CONTRACTOR - IF A CORPORATION

STATE OF NEW YORK
COUNTY OF QUEENS

ON THE 1st DAY OF JUNE, 2017 BEFORE ME PERSONALLY APPEARED Peter K. Tully TO ME KNOWN, WHO, BEING BY ME DULY SWORN, DID DEPOSE AND SAY; THAT (S)HE IS THE CHIEF EXECUTIVE OFFICER OF Thalle Construction Co., Inc. THE CORPORATION THAT EXECUTED THE FOREGOING INSTRUMENT, AND ACKNOWLEDGED TO ME THAT SUCH CORPORATION EXECUTED THE SAME.

IN WITNESS WHEREOF, I HAVE HEREUNTO SET MY HAND AND AFFIXED MY OFFICIAL SEAL, AT MY OFFICE IN THE ABOVE COUNTY, THE DAY AND YEAR WRITTEN ABOVE.

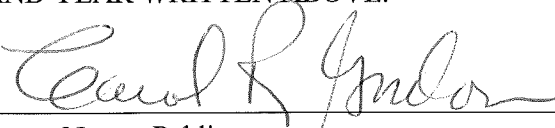

Notary Public

CAROL R. GORDON
Notary Public, State of New York
No. 01GO4680187
Qualified in Queens County
Commission Expires April 30, 2018

ACKNOWLEDGEMENT OF SURETY COMPANY

STATE OF NEW JERSEY
COUNTY OF MORRIS

ON THE 1st DAY OF JUNE, 2017 BEFORE ME PERSONALLY APPEARED Krystal L. Stravato TO ME KNOWN, WHO BEING BY ME DULY SWORN, DID DEPOSE AND SAY; THAT (S)HE IS THE ATTORNEY-IN-FACT OF Federal Insurance Company, THE CORPORATION THAT EXECUTED THE FOREGOING INSTRUMENT, AND ACKNOWLEDGED TO ME THAT SUCH CORPORATION EXECUTED THE SAME.

IN WITNESS WHEREOF, I HAVE HEREUNTO SET MY HAND AND AFFIXED MY OFFICIAL SEAL, AT MY OFFICE IN THE ABOVE COUNTY, THE DAY AND YEAR WRITTEN ABOVE.



Notary Public

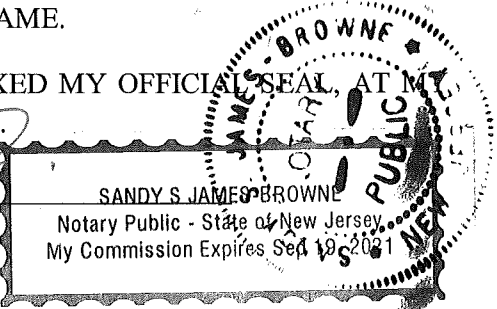

ACKNOWLEDGEMENT OF SURETY COMPANY

STATE OF NEW JERSEY
COUNTY OF MORRIS

ON THE 1st DAY OF JUNE, 2017 BEFORE ME PERSONALLY APPEARED Krystal L. Stravato TO ME KNOWN, WHO BEING BY ME DULY SWORN, DID DEPOSE AND SAY; THAT (S)HE IS THE ATTORNEY-IN-FACT OF Liberty Mutual Insurance Company THE CORPORATION THAT EXECUTED THE FOREGOING INSTRUMENT, AND ACKNOWLEDGED TO ME THAT SUCH CORPORATION EXECUTED THE SAME.

IN WITNESS WHEREOF, I HAVE HEREUNTO SET MY HAND AND AFFIXED MY OFFICIAL SEAL, AT MY OFFICE IN THE ABOVE COUNTY, THE DAY AND YEAR WRITTEN ABOVE.

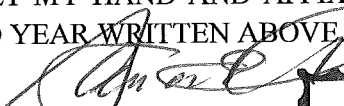

Notary Public

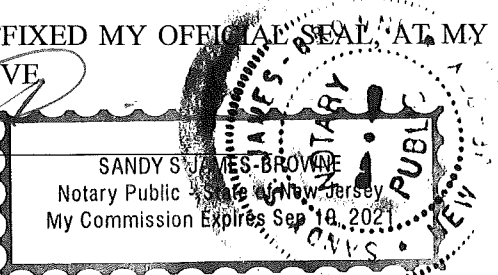

FEDERAL INSURANCE COMPANY

STATEMENT OF ASSETS, LIABILITIES AND SURPLUS TO POLICYHOLDERS

Statutory Basis

DECEMBER 31, 2016

(in thousands of dollars)

| <u>ASSETS</u> | | <u>LIABILITIES AND SURPLUS TO POLICYHOLDERS</u> | |
|--|----------------------|--|----------------------|
| Cash and Short Term Investments..... | \$ (86,990) | Outstanding Losses and Loss Expenses..... | \$ 11,482,308 |
| United States Government, State and Municipal Bonds | 8,135,311 | Unearned Premiums..... | 2,723,875 |
| Other Bonds..... | 5,471,330 | Ceded Reinsurance Premiums Payable..... | 566,868 |
| Stocks..... | 130,689 | Provision for Reinsurance | 29,339 |
| Other Invested Assets..... | 1,289,903 | Other Liabilities..... | 1,144,976 |
| | | | |
| TOTAL INVESTMENTS | 14,940,243 | TOTAL LIABILITIES | 15,947,366 |
| | | | |
| Investments in Affiliates: | | Capital Stock..... | 20,980 |
| Chubb Investment Holdings, Inc. | 3,727,406 | Paid-In Surplus..... | 3,106,809 |
| Pacific Indemnity Company..... | 2,926,619 | Unassigned Funds | 8,296,020 |
| Executive Risk Indemnity Inc..... | 1,250,965 | | |
| Great Northern Insurance Company | 504,162 | | |
| Vigilant Insurance Company..... | 319,505 | SURPLUS TO POLICYHOLDERS..... | 11,423,809 |
| Chubb European Investment Holdings, SLP . | 277,361 | | |
| Chubb Custom Insurance Company..... | 214,956 | | |
| Chubb National Insurance Company | 162,929 | | |
| Chubb Indemnity Insurance Company..... | 163,668 | | |
| Other Affiliates | 70,204 | | |
| Premiums Receivable | 1,510,107 | | |
| Other Assets | 1,303,050 | | |
| | | | |
| TOTAL ADMITTED ASSETS | \$ 27,371,175 | TOTAL LIABILITIES AND SURPLUS TO POLICYHOLDERS..... | \$ 27,371,175 |

Investments are valued in accordance with requirements of the National Association of Insurance Commissioners.
At December 31, 2016, investments with a carrying value of \$665,702,495 were deposited with government authorities as required by law.

State, County & City of New York, — ss:

Dawn M. Chloros, Assistant Secretary _____ of the Federal Insurance Company

being duly sworn, deposes and says that the foregoing Statement of Assets, Liabilities and Surplus to Policyholders of said Federal Insurance Company on December 31, 2016 is true and correct and is a true abstract of the Annual Statement of said Company as filed with the Secretary of the Treasury of the United States for the 12 months ending December 31, 2016.

Subscribed and sworn to before me
this March 3, 2017.

Jeanette Shipsey

Notary Public

JEANETTE SHIPSEY
Notary Public, State of New York
No. 02SH5074142
Qualified in Nassau County
Commission Expires March 10, 2019

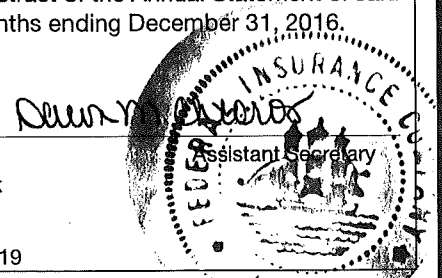



LIBERTY MUTUAL INSURANCE COMPANY
FINANCIAL STATEMENT — DECEMBER 31, 2016

| Assets | Liabilities |
|---|--|
| Cash and Bank Deposits..... \$1,092,914,837 | Unearned Premiums..... \$6,929,723,299 |
| *Bonds — U.S Government..... 1,406,763,970 | Reserve for Claims and Claims Expense..... 17,233,877,300 |
| *Other Bonds..... 11,379,916,523 | Funds Held Under Reinsurance Treaties..... 208,362,823 |
| *Stocks 10,349,761,988 | Reserve for Dividends to Policyholders..... 944,909 |
| Real Estate..... 290,265,760 | Additional Statutory Reserve..... 39,649,905 |
| Agents' Balances or Uncollected Premiums..... 4,709,977,463 | Reserve for Commissions, Taxes and |
| Accrued Interest and Rents..... 112,757,395 | Other Liabilities <u>3,061,117,958</u> |
| Other Admitted Assets..... <u>14,659,523,751</u> | Total \$27,473,676,194 |
| | Special Surplus Funds..... \$95,257,334 |
| | Capital Stock..... 10,000,000 |
| | Paid in Surplus..... 9,229,250,104 |
| | Unassigned Surplus..... 7,193,698,055 |
| | Surplus to Policyholders <u>16,528,205,493</u> |
| Total Admitted Assets..... <u>\$44,001,881,687</u> | Total Liabilities and Surplus <u>\$44,001,881,687</u> |



* Bonds are stated at amortized or investment value; Stocks at Association Market Values.
The foregoing financial information is taken from Liberty Mutual Insurance Company's financial statement filed with the state of Massachusetts Department of Insurance.

I, TIM MIKOLAJEWSKI, Assistant Secretary of Liberty Mutual Insurance Company, do hereby certify that the foregoing is a true, and correct statement of the Assets and Liabilities of said Corporation, as of December 31, 2016, to the best of my knowledge and belief.

IN WITNESS WHEREOF, I have hereunto set my hand and affixed the seal of said Corporation at Seattle, Washington, this 23rd day of March, 2017.

T. Mikolajewski

Assistant Secretary

Power of Attorney

Federal Insurance Company | Vigilant Insurance Company | Pacific Indemnity Company

Know All by These Presents, That FEDERAL INSURANCE COMPANY, an Indiana corporation, VIGILANT INSURANCE COMPANY, a New York corporation, and PACIFIC INDEMNITY COMPANY, a Wisconsin corporation, do each hereby constitute and appoint Ricardo Davila, Will Griffin and Michael Marino of Miami, Florida; Thomas MacDonald, Krystal L. Stravato and Kevin T. Walsh, Jr. of Cedar Knolls, New Jersey; Theresa J. Foley and Frankie Grella of Jericho, New York; Neil C. Donovan, Gerard Leib and Mary C. McGinn of Berwyn, Pennsylvania

each as their true and lawful Attorney-in-Fact to execute under such designation in their names and to affix their corporate seals to and deliver for and on their behalf as surety thereon or otherwise, bonds and undertakings and other writings obligatory in the nature thereof (other than bail bonds) given or executed in the course of business, and any instruments amending or altering the same, and consents to the modification or alteration of any instrument referred to in said bonds or obligations.

In Witness Whereof, said FEDERAL INSURANCE COMPANY, VIGILANT INSURANCE COMPANY, and PACIFIC INDEMNITY COMPANY have each executed and attested these presents and affixed their corporate seals on this 30th day of March, 2017.

Dawn M. Chloros

Dawn M. Chloros, Assistant Secretary

Stephen M. Haney

Stephen M. Haney, Vice President



STATE OF NEW JERSEY

County of Hunterdon

ss.

On this 30th day of March, 2017 before me, a Notary Public of New Jersey, personally came Dawn M. Chloros, to me known to be Assistant Secretary of FEDERAL INSURANCE COMPANY, VIGILANT INSURANCE COMPANY, and PACIFIC INDEMNITY COMPANY, the companies which executed the foregoing Power of Attorney, and the said Dawn M. Chloros, being by me duly sworn, did depose and say that she is Assistant Secretary of FEDERAL INSURANCE COMPANY, VIGILANT INSURANCE COMPANY, and PACIFIC INDEMNITY COMPANY and knows the corporate seals thereof, that the seals affixed to the foregoing Power of Attorney are such corporate seals and were thereto affixed by authority of said Companies; and that she signed said Power of Attorney as Assistant Secretary of said Companies by like authority; and that she is acquainted with Stephen M. Haney, and knows him to be Vice President of said Companies; and that the signature of Stephen M. Haney, subscribed to said Power of Attorney is in the genuine handwriting of Stephen M. Haney, and was thereto subscribed by authority of said Companies and in deponent's presence.

Notarial Seal



KATHERINE J. ADELAAR
NOTARY PUBLIC OF NEW JERSEY
No. 2318886
Commission Expires July 16, 2019

[Signature]
Notary Public

CERTIFICATION

Resolutions adopted by the Boards of Directors of FEDERAL INSURANCE COMPANY, VIGILANT INSURANCE COMPANY, and PACIFIC INDEMNITY COMPANY on August 30, 2016:

"RESOLVED, that the following authorizations relate to the execution, for and on behalf of the Company, of bonds, undertakings, recognizances, contracts and other written commitments of the Company entered into in the ordinary course of business (each a "Written Commitment"):

- (1) Each of the Chairman, the President and the Vice Presidents of the Company is hereby authorized to execute any Written Commitment for and on behalf of the Company, under the seal of the Company or otherwise.
(2) Each duly appointed attorney-in-fact of the Company is hereby authorized to execute any Written Commitment for and on behalf of the Company, under the seal of the Company or otherwise, to the extent that such action is authorized by the grant of powers provided for in such person's written appointment as such attorney-in-fact.
(3) Each of the Chairman, the President and the Vice Presidents of the Company is hereby authorized, for and on behalf of the Company, to appoint in writing any person the attorney-in-fact of the Company with full power and authority to execute, for and on behalf of the Company, under the seal of the Company or otherwise, such Written Commitments of the Company as may be specified in such written appointment, which specification may be by general type or class of Written Commitments or by specification of one or more particular Written Commitments.
(4) Each of the Chairman, the President and the Vice Presidents of the Company is hereby authorized, for and on behalf of the Company, to delegate in writing to any other officer of the Company the authority to execute, for and on behalf of the Company, under the Company's seal or otherwise, such Written Commitments of the Company as are specified in such written delegation, which specification may be by general type or class of Written Commitments or by specification of one or more particular Written Commitments.
(5) The signature of any officer or other person executing any Written Commitment or appointment or delegation pursuant to this Resolution, and the seal of the Company, may be affixed by facsimile on such Written Commitment or written appointment or delegation.

FURTHER RESOLVED, that the foregoing Resolution shall not be deemed to be an exclusive statement of the powers and authority of officers, employees and other persons to act for and on behalf of the Company, and such Resolution shall not limit or otherwise affect the exercise of any such power or authority otherwise validly granted or vested."

I, Dawn M. Chloros, Assistant Secretary of FEDERAL INSURANCE COMPANY, VIGILANT INSURANCE COMPANY, and PACIFIC INDEMNITY COMPANY (the "Companies") do hereby certify that

- (i) the foregoing Resolutions adopted by the Board of Directors of the Companies are true, correct and in full force and effect,
(ii) the Companies are duly licensed and authorized to transact surety business in all 50 of the United States of America and the District of Columbia and are authorized by the U.S. Treasury Department; further, Federal and Vigilant are licensed in the U.S. Virgin Islands, and Federal is licensed in Guam, Puerto Rico, and each of the Provinces of Canada except Prince Edward Island; and
(iii) the foregoing Power of Attorney is true, correct and in full force and effect.

Given under my hand and seals of said Companies at Whitehouse Station, NJ, this June 1, 2017.

Dawn M. Chloros

Dawn M. Chloros, Assistant Secretary

IN THE EVENT YOU WISH TO NOTIFY US OF A CLAIM, VERIFY THE AUTHENTICITY OF THIS BOND OR NOTIFY US OF ANY OTHER MATTER, PLEASE CONTACT US AT: Telephone (908) 903-3493 Fax (908) 903-3656 e-mail: surety@chubb.com

THIS POWER OF ATTORNEY IS NOT VALID UNLESS IT IS PRINTED ON RED BACKGROUND.

This Power of Attorney limits the acts of those named herein, and they have no authority to bind the Company except in the manner and to the extent herein stated.

Certificate No. 7689082

Liberty Mutual Insurance Company
The Ohio Casualty Insurance Company West American Insurance Company

POWER OF ATTORNEY

KNOWN ALL PERSONS BY THESE PRESENTS: That The Ohio Casualty Insurance Company is a corporation duly organized under the laws of the State of New Hampshire, that Liberty Mutual Insurance Company is a corporation duly organized under the laws of the State of Massachusetts, and West American Insurance Company is a corporation duly organized under the laws of the State of Indiana (herein collectively called the "Companies"), pursuant to and by authority herein set forth, does hereby name, constitute and appoint, Kevin T. Walsh, Jr.; Krystal L. Stravato; Michael Marino; Thomas MacDonald

all of the city of Cedar Knolls, state of NJ each individually if there be more than one named, its true and lawful attorney-in-fact to make, execute, seal, acknowledge and deliver, for and on its behalf as surety and as its act and deed, any and all undertakings, bonds, recognizances and other surety obligations, in pursuance of these presents and shall be as binding upon the Companies as if they have been duly signed by the president and attested by the secretary of the Companies in their own proper persons.

IN WITNESS WHEREOF, this Power of Attorney has been subscribed by an authorized officer or official of the Companies and the corporate seals of the Companies have been affixed thereto this 23rd day of March, 2017.



The Ohio Casualty Insurance Company
Liberty Mutual Insurance Company
West American Insurance Company

By: David M. Carey
David M. Carey, Assistant Secretary

STATE OF PENNSYLVANIA ss
COUNTY OF MONTGOMERY

On this 23rd day of March, 2017, before me personally appeared David M. Carey, who acknowledged himself to be the Assistant Secretary of Liberty Mutual Insurance Company, The Ohio Casualty Company, and West American Insurance Company, and that he, as such, being authorized so to do, execute the foregoing instrument for the purposes therein contained by signing on behalf of the corporations by himself as a duly authorized officer.

IN WITNESS WHEREOF, I have hereunto subscribed my name and affixed my notarial seal at King of Prussia, Pennsylvania, on the day and year first above written.



COMMONWEALTH OF PENNSYLVANIA
Notarial Seal
Teresa Pastella, Notary Public
Upper Merion Twp., Montgomery County
My Commission Expires March 28, 2021
Member, Pennsylvania Association of Notaries

By: Teresa Pastella
Teresa Pastella, Notary Public

This Power of Attorney is made and executed pursuant to and by authority of the following By-laws and Authorizations of The Ohio Casualty Insurance Company, Liberty Mutual Insurance Company, and West American Insurance Company which resolutions are now in full force and effect reading as follows:

ARTICLE IV – OFFICERS – Section 12. Power of Attorney. Any officer or other official of the Corporation authorized for that purpose in writing by the Chairman or the President, and subject to such limitation as the Chairman or the President may prescribe, shall appoint such attorneys-in-fact, as may be necessary to act in behalf of the Corporation to make, execute, seal, acknowledge and deliver as surety any and all undertakings, bonds, recognizances and other surety obligations. Such attorneys-in-fact, subject to the limitations set forth in their respective powers of attorney, shall have full power to bind the Corporation by their signature and execution of any such instruments and to attach thereto the seal of the Corporation. When so executed, such instruments shall be as binding as if signed by the President and attested to by the Secretary. Any power or authority granted to any representative or attorney-in-fact under the provisions of this article may be revoked at any time by the Board, the Chairman, the President or by the officer or officers granting such power or authority.

ARTICLE XIII – Execution of Contracts – SECTION 5. Surety Bonds and Undertakings. Any officer of the Company authorized for that purpose in writing by the chairman or the president, and subject to such limitations as the chairman or the president may prescribe, shall appoint such attorneys-in-fact, as may be necessary to act in behalf of the Company to make, execute, seal, acknowledge and deliver as surety any and all undertakings, bonds, recognizances and other surety obligations. Such attorneys-in-fact subject to the limitations set forth in their respective powers of attorney, shall have full power to bind the Company by their signature and execution of any such instruments and to attach thereto the seal of the Company. When so executed such instruments shall be as binding as if signed by the president and attested by the secretary.

Certificate of Designation – The President of the Company, acting pursuant to the Bylaws of the Company, authorizes David M. Carey, Assistant Secretary to appoint such attorneys-in-fact as may be necessary to act on behalf of the Company to make, execute, seal, acknowledge and deliver as surety any and all undertakings, bonds, recognizances and other surety obligations.

Authorization – By unanimous consent of the Company's Board of Directors, the Company consents that facsimile or mechanically reproduced signature of any assistant secretary of the Company, wherever appearing upon a certified copy of any power of attorney issued by the Company in connection with surety bonds, shall be valid and binding upon the Company with the same force and effect as though manually affixed.

I, Renee C. Llewellyn, the undersigned, Assistant Secretary, The Ohio Casualty Insurance Company, Liberty Mutual Insurance Company, and West American Insurance Company do hereby certify that the original power of attorney of which the foregoing is a full, true and correct copy of the Power of Attorney executed by said Companies, is in full force and effect and has not been revoked.

IN TESTIMONY WHEREOF, I have hereunto set my hand and affixed the seals of said Companies this 1st day of June, 2017.



By: Renee C. Llewellyn
Renee C. Llewellyn, Assistant Secretary

Not valid for mortgage, note, loan, letter of credit, currency rate, interest rate or residual value guarantees.

To confirm the validity of this Power of Attorney call 1-610-832-8240 between 9:00 am and 4:30 pm EST on any business day.

Contract No. C203844
County Alamance

Rev 5-17-11

Bond No. 8245-21-10 Federal Insurance Company
Bond No. 015053854 Liberty Mutual Insurance Company

CONTRACT PERFORMANCE BOND

Date of Performance Bond Execution: June 1, 2017

Name of Principal Contractor: Thalle Construction Company, Inc.
Federal Insurance Company, 15 Mountain View Road, Warren, NJ 07059

Name of Surety: Liberty Mutual Insurance Company, 175 Berkeley Street, Boston, MA 02116

Name of Contracting Body: **North Carolina Department of Transportation**
Raleigh, North Carolina

Amount of Bond: \$45,389,069.36

Contract ID No.: C203844

County Name: Alamance

KNOW ALL MEN BY THESE PRESENTS, That we, the PRINCIPAL CONTRACTOR (hereafter, PRINCIPAL) and SURETY above named, are held and firmly bound unto the above named Contracting Body, hereinafter called the Contracting Body, in the penal sum of the amount stated above for the payment of which sum well and truly to be made, we bind ourselves, our heirs, executors, administrators, and successors, jointly and severally, firmly by these presents.

THE CONDITION OF THIS OBLIGATION IS SUCH, that whereas the principal entered into a certain contract with the Contracting Body, numbered as shown above and hereto attached:

NOW THEREFORE, if the principal shall well and truly perform and fulfill all the undertakings, covenants, terms, conditions, and agreements of said contract during the original term of said contract and any extensions thereof that may be granted by the Contracting Body, with or without notice to the Surety, and during the life of any guaranty required under the contract, and shall also well and truly perform and fulfill all the undertakings, covenants, terms, conditions, and agreements of any and all duly authorized modifications of said contract that may hereafter be made, notice of which modifications to the surety being hereby waived, then this obligation to be void; otherwise to remain in full force and virtue.

IN WITNESS WHEREOF, the above-bound parties have executed this instrument under their several seals on the date indicated above, the name and corporate seal of each corporate party being hereto affixed and these presents duly signed by its undersigned representative, pursuant to authority of its governing body.

Contract No. C203844
County Alamance

Rev 5-17-11

CONTRACT PERFORMANCE BOND

Federal Insurance Company
Liberty Mutual Insurance Company
Print or type Surety Company Name

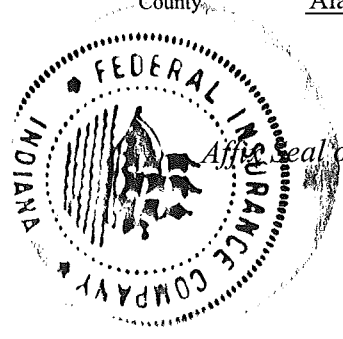

Affidavit Seal of Surety Company

By Krystal L. Stravato, Attorney-In-Fact
Print, stamp or type name of Attorney-in-Fact

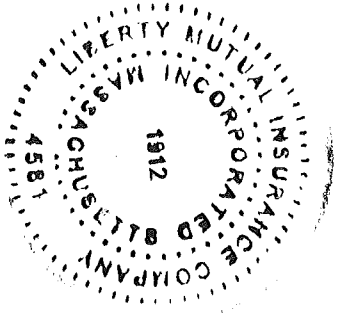

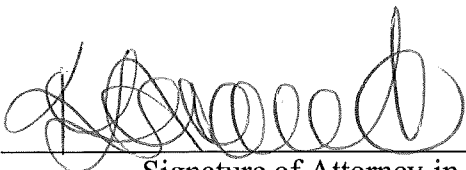
Signature of Attorney-in-Fact

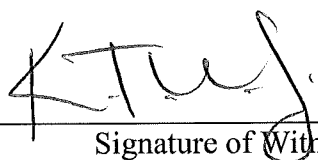
Signature of Witness

Kevin T. Walsh, Jr., Witness
Print or type Signer's name

240 Cedar Knolls Road, Suite 202
Cedar Knolls, NJ 07927
Address of Attorney-in-Fact

Contract No.
County

C203844
Alamance

Rev 5-17-11

CONTRACT PERFORMANCE BOND
CORPORATION

SIGNATURE OF CONTRACTOR (Principal)

Thalle Construction Company, Inc.
Full name of Corporation

900 NC 86 North, Hillsborough, NC 27278
Address as prequalified

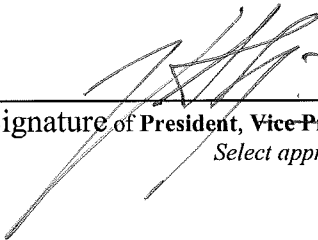
By 
Signature of ~~President~~, ~~Vice President~~, ~~Assistant Vice President~~
Select appropriate title

Peter K. Tully, Chief Executive Officer
Print or type Signer's name

Affix Corporate Seal

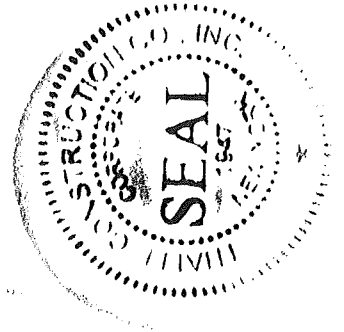

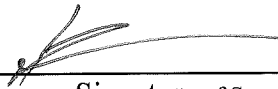
Attest 
Signature of ~~Secretary~~, ~~Assistant Secretary~~
Select appropriate title

Kenneth W. Tully
Print or type Signer's name

Contract No.
County

C203844
Alamance

Rev 5-17-11

CONTRACT PERFORMANCE BOND

Attach certified copy of Power of Attorney to this sheet

ACKNOWLEDGEMENT OF CONTRACTOR - IF A CORPORATION

STATE OF NEW YORK
COUNTY OF QUEENS

ON THE 1st DAY OF JUNE, 2017 BEFORE ME PERSONALLY APPEARED Peter K. Tully TO ME KNOWN, WHO, BEING BY ME DULY SWORN, DID DEPOSE AND SAY; THAT (S)HE IS THE CHIEF EXECUTIVE OFFICER OF Thalle Construction Co., Inc. THE CORPORATION THAT EXECUTED THE FOREGOING INSTRUMENT, AND ACKNOWLEDGED TO ME THAT SUCH CORPORATION EXECUTED THE SAME.

IN WITNESS WHEREOF, I HAVE HEREUNTO SET MY HAND AND AFFIXED MY OFFICIAL SEAL, AT MY OFFICE IN THE ABOVE COUNTY, THE DAY AND YEAR WRITTEN ABOVE.



Notary Public

CAROL R. GORDON
Notary Public, State of New York
No. 01GO4680187
Qualified in Queens County
Commission Expires April 30, 2018

ACKNOWLEDGEMENT OF SURETY COMPANY

STATE OF NEW JERSEY
COUNTY OF MORRIS

ON THE 1st DAY OF JUNE, 2017 BEFORE ME PERSONALLY APPEARED Krystal L. Stravato TO ME KNOWN, WHO BEING BY ME DULY SWORN, DID DEPOSE AND SAY; THAT (S)HE IS THE ATTORNEY-IN-FACT OF Federal Insurance Company, THE CORPORATION THAT EXECUTED THE FOREGOING INSTRUMENT, AND ACKNOWLEDGED TO ME THAT SUCH CORPORATION EXECUTED THE SAME.

IN WITNESS WHEREOF, I HAVE HEREUNTO SET MY HAND AND AFFIXED MY OFFICIAL SEAL, AT MY OFFICE IN THE ABOVE COUNTY, THE DAY AND YEAR WRITTEN ABOVE.



Notary Public

SANDY S. JAMES-BROWNE
Notary Public - State of New Jersey
My Commission Expires Sep 19, 2021

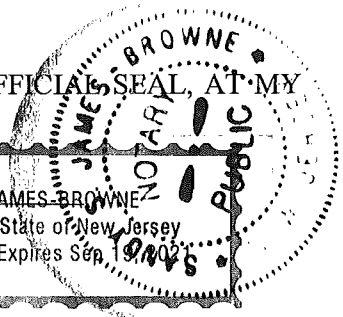

ACKNOWLEDGEMENT OF SURETY COMPANY

STATE OF NEW JERSEY
COUNTY OF MORRIS

ON THE 1st DAY OF JUNE, 2017 BEFORE ME PERSONALLY APPEARED Krystal L. Stravato TO ME KNOWN, WHO BEING BY ME DULY SWORN, DID DEPOSE AND SAY; THAT (S)HE IS THE ATTORNEY-IN-FACT OF Liberty Mutual Insurance Company THE CORPORATION THAT EXECUTED THE FOREGOING INSTRUMENT, AND ACKNOWLEDGED TO ME THAT SUCH CORPORATION EXECUTED THE SAME.

IN WITNESS WHEREOF, I HAVE HEREUNTO SET MY HAND AND AFFIXED MY OFFICIAL SEAL, AT MY OFFICE IN THE ABOVE COUNTY, THE DAY AND YEAR WRITTEN ABOVE.



Notary Public

SANDY S. JAMES-BROWNE
Notary Public - State of New Jersey
My Commission Expires Sep 19, 2021



FEDERAL INSURANCE COMPANY

STATEMENT OF ASSETS, LIABILITIES AND SURPLUS TO POLICYHOLDERS

Statutory Basis

DECEMBER 31, 2016

(in thousands of dollars)

| <u>ASSETS</u> | | <u>LIABILITIES AND SURPLUS TO POLICYHOLDERS</u> | |
|--|----------------------|---|----------------------|
| Cash and Short Term Investments..... | \$ (86,990) | Outstanding Losses and Loss Expenses | \$ 11,482,308 |
| United States Government, State and Municipal Bonds | 8,135,311 | Unearned Premiums..... | 2,723,875 |
| Other Bonds..... | 5,471,330 | Ceded Reinsurance Premiums Payable..... | 566,868 |
| Stocks | 130,689 | Provision for Reinsurance | 29,339 |
| Other Invested Assets..... | <u>1,289,903</u> | Other Liabilities..... | <u>1,144,976</u> |
| | | | |
| TOTAL INVESTMENTS | <u>14,940,243</u> | TOTAL LIABILITIES | <u>15,947,366</u> |
| | | | |
| Investments in Affiliates: | | Capital Stock..... | 20,980 |
| Chubb Investment Holdings, Inc. | 3,727,406 | Paid-In Surplus..... | 3,106,809 |
| Pacific Indemnity Company..... | 2,926,619 | Unassigned Funds | <u>8,296,020</u> |
| Executive Risk Indemnity Inc..... | 1,250,965 | | |
| Great Northern Insurance Company | 504,162 | | |
| Vigilant Insurance Company..... | 319,505 | | |
| Chubb European Investment Holdings, SLP . | 277,361 | SURPLUS TO POLICYHOLDERS..... | <u>11,423,809</u> |
| Chubb Custom Insurance Company..... | 214,956 | | |
| Chubb National Insurance Company | 162,929 | | |
| Chubb Indemnity Insurance Company..... | 163,668 | | |
| Other Affiliates | 70,204 | | |
| Premiums Receivable | 1,510,107 | | |
| Other Assets | <u>1,303,050</u> | | |
| | | | |
| TOTAL ADMITTED ASSETS | <u>\$ 27,371,175</u> | TOTAL LIABILITIES AND SURPLUS TO POLICYHOLDERS..... | <u>\$ 27,371,175</u> |

Investments are valued in accordance with requirements of the National Association of Insurance Commissioners. At December 31, 2016, investments with a carrying value of \$565,702,495 were deposited with government authorities as required by law.

State, County & City of New York, — ss:

Dawn M. Chloros, Assistant Secretary _____ of the Federal Insurance Company

being duly sworn, deposes and says that the foregoing Statement of Assets, Liabilities and Surplus to Policyholders of said Federal Insurance Company on December 31, 2016 is true and correct and is a true abstract of the Annual Statement of said Company as filed with the Secretary of the Treasury of the United States for the 12 months ending December 31, 2016.

Subscribed and sworn to before me
this March 3, 2017.

Jeanette Shipsey

Notary Public

JEANETTE SHIPSEY
Notary Public, State of New York
No. 02SH5074142
Qualified in Nassau County
Commission Expires March 10, 2019

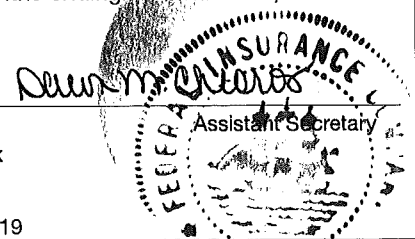



LIBERTY MUTUAL INSURANCE COMPANY
FINANCIAL STATEMENT — DECEMBER 31, 2016

| Assets | Liabilities |
|---|--|
| Cash and Bank Deposits..... \$1,092,914,837 | Unearned Premiums..... \$6,929,723,299 |
| *Bonds — U.S Government 1,406,763,970 | Reserve for Claims and Claims Expense..... 17,233,877,300 |
| *Other Bonds..... 11,379,916,523 | Funds Held Under Reinsurance Treaties..... 208,362,823 |
| *Stocks 10,349,761,988 | Reserve for Dividends to Policyholders..... 944,909 |
| Real Estate..... 290,265,760 | Additional Statutory Reserve 39,649,905 |
| Agents' Balances or Uncollected Premiums..... 4,709,977,463 | Reserve for Commissions, Taxes and |
| Accrued Interest and Rents..... 112,757,395 | Other Liabilities <u>3,061,117,958</u> |
| Other Admitted Assets..... <u>14,659,523,751</u> | Total \$27,473,676,194 |
| Total Admitted Assets..... <u>\$44,001,881,687</u> | Special Surplus Funds..... \$95,257,334 |
| | Capital Stock..... 10,000,000 |
| | Paid in Surplus..... 9,229,250,104 |
| | Unassigned Surplus..... 7,193,698,055 |
| | Surplus to Policyholders <u>16,528,205,493</u> |
| | Total Liabilities and Surplus <u>\$44,001,881,687</u> |



* Bonds are stated at amortized or investment value; Stocks at Association Market Values.
The foregoing financial information is taken from Liberty Mutual Insurance Company's financial statement filed with the state of Massachusetts Department of Insurance.

I, TIM MIKOLAJEWSKI, Assistant Secretary of Liberty Mutual Insurance Company, do hereby certify that the foregoing is a true, and correct statement of the Assets and Liabilities of said Corporation, as of December 31, 2016, to the best of my knowledge and belief.

IN WITNESS WHEREOF, I have hereunto set my hand and affixed the seal of said Corporation at Seattle, Washington, this 23rd day of March, 2017.

TAMIKOLAJEWSKI

Assistant Secretary

Power of Attorney

Federal Insurance Company | Vigilant Insurance Company | Pacific Indemnity Company

Know All by These Presents, That FEDERAL INSURANCE COMPANY, an Indiana corporation, VIGILANT INSURANCE COMPANY, a New York corporation, and PACIFIC INDEMNITY COMPANY, a Wisconsin corporation, do each hereby constitute and appoint Ricardo Davila, Will Griffin and Michael Marino of Miami, Florida; Thomas MacDonald, Krystal L. Stravato and Kevin T. Walsh, Jr. of Cedar Knolls, New Jersey; Theresa J. Foley and Frankie Grella of Jericho, New York; Neil C. Donovan, Gerard Leib and Mary C. McGinn of Berwyn, Pennsylvania

each as their true and lawful Attorney-in-Fact to execute under such designation in their names and to affix their corporate seals to and deliver for and on their behalf as surety thereon or otherwise, bonds and undertakings and other writings obligatory in the nature thereof (other than bail bonds) given or executed in the course of business, and any instruments amending or altering the same, and consents to the modification or alteration of any instrument referred to in said bonds or obligations.

In Witness Whereof, said FEDERAL INSURANCE COMPANY, VIGILANT INSURANCE COMPANY, and PACIFIC INDEMNITY COMPANY have each executed and attested these presents and affixed their corporate seals on this 30th day of March, 2017.

Dawn M. Chloros

Dawn M. Chloros, Assistant Secretary

Stephen M. Haney

Stephen M. Haney, Vice President



STATE OF NEW JERSEY

County of Hunterdon

ss.

On this 30th day of March, 2017 before me, a Notary Public of New Jersey, personally came Dawn M. Chloros, to me known to be Assistant Secretary of FEDERAL INSURANCE COMPANY, VIGILANT INSURANCE COMPANY, and PACIFIC INDEMNITY COMPANY, the companies which executed the foregoing Power of Attorney, and the said Dawn M. Chloros, being by me duly sworn, did depose and say that she is Assistant Secretary of FEDERAL INSURANCE COMPANY, VIGILANT INSURANCE COMPANY, and PACIFIC INDEMNITY COMPANY and knows the corporate seals thereof, that the seals affixed to the foregoing Power of Attorney are such corporate seals and were thereto affixed by authority of said Companies; and that she signed said Power of Attorney as Assistant Secretary of said Companies by like authority; and that she is acquainted with Stephen M. Haney, and knows him to be Vice President of said Companies; and that the signature of Stephen M. Haney, subscribed to said Power of Attorney is in the genuine handwriting of Stephen M. Haney, and was thereto subscribed by authority of said Companies and in deponent's presence.

Notarial Seal



KATHERINE J. ADELAAR
NOTARY PUBLIC OF NEW JERSEY
No. 2318885
Commission Expires July 16, 2019

Signature of Katherine J. Adelaar

Notary Public

CERTIFICATION

Resolutions adopted by the Boards of Directors of FEDERAL INSURANCE COMPANY, VIGILANT INSURANCE COMPANY, and PACIFIC INDEMNITY COMPANY on August 30, 2016:

"RESOLVED, that the following authorizations relate to the execution, for and on behalf of the Company, of bonds, undertakings, recognizances, contracts and other written commitments of the Company entered into in the ordinary course of business (each a "Written Commitment"):

- (1) Each of the Chairman, the President and the Vice Presidents of the Company is hereby authorized to execute any Written Commitment for and on behalf of the Company, under the seal of the Company or otherwise.
(2) Each duly appointed attorney-in-fact of the Company is hereby authorized to execute any Written Commitment for and on behalf of the Company, under the seal of the Company or otherwise, to the extent that such action is authorized by the grant of powers provided for in such person's written appointment as such attorney-in-fact.
(3) Each of the Chairman, the President and the Vice Presidents of the Company is hereby authorized, for and on behalf of the Company, to appoint in writing any person the attorney-in-fact of the Company with full power and authority to execute, for and on behalf of the Company, under the seal of the Company or otherwise, such Written Commitments of the Company as may be specified in such written appointment, which specification may be by general type or class of Written Commitments or by specification of one or more particular Written Commitments.
(4) Each of the Chairman, the President and the Vice Presidents of the Company is hereby authorized, for and on behalf of the Company, to delegate in writing to any other officer of the Company the authority to execute, for and on behalf of the Company, under the Company's seal or otherwise, such Written Commitments of the Company as are specified in such written delegation, which specification may be by general type or class of Written Commitments or by specification of one or more particular Written Commitments.
(5) The signature of any officer or other person executing any Written Commitment or appointment or delegation pursuant to this Resolution, and the seal of the Company, may be affixed by facsimile on such Written Commitment or written appointment or delegation.

FURTHER RESOLVED, that the foregoing Resolution shall not be deemed to be an exclusive statement of the powers and authority of officers, employees and other persons to act for and on behalf of the Company, and such Resolution shall not limit or otherwise affect the exercise of any such power or authority otherwise validly granted or vested."

I, Dawn M. Chloros, Assistant Secretary of FEDERAL INSURANCE COMPANY, VIGILANT INSURANCE COMPANY, and PACIFIC INDEMNITY COMPANY (the "Companies") do hereby certify that

- (i) the foregoing Resolutions adopted by the Board of Directors of the Companies are true, correct and in full force and effect,
(ii) the Companies are duly licensed and authorized to transact surety business in all 50 of the United States of America and the District of Columbia and are authorized by the U.S. Treasury Department; further, Federal and Vigilant are licensed in the U.S. Virgin Islands, and Federal is licensed in Guam, Puerto Rico, and each of the Provinces of Canada except Prince Edward Island; and
(iii) the foregoing Power of Attorney is true, correct and in full force and effect.

Given under my hand and seals of said Companies at Whitehouse Station, NJ, this June 1, 2017.

Dawn M. Chloros

Dawn M. Chloros, Assistant Secretary



IN THE EVENT YOU WISH TO NOTIFY US OF A CLAIM, VERIFY THE AUTHENTICITY OF THIS BOND OR NOTIFY US OF ANY OTHER MATTER, PLEASE CONTACT US AT: Telephone (908) 903-3493 Fax (908) 903-3656 e-mail: surety@chubb.com

THIS POWER OF ATTORNEY IS NOT VALID UNLESS IT IS PRINTED ON RED BACKGROUND.

This Power of Attorney limits the acts of those named herein, and they have no authority to bind the Company except in the manner and to the extent herein stated.

Certificate No. 7689081

Liberty Mutual Insurance Company
The Ohio Casualty Insurance Company West American Insurance Company

POWER OF ATTORNEY

KNOWN ALL PERSONS BY THESE PRESENTS: That The Ohio Casualty Insurance Company is a corporation duly organized under the laws of the State of New Hampshire, that Liberty Mutual Insurance Company is a corporation duly organized under the laws of the State of Massachusetts, and West American Insurance Company is a corporation duly organized under the laws of the State of Indiana (herein collectively called the "Companies"), pursuant to and by authority herein set forth, does hereby name, constitute and appoint, Kevin T. Walsh, Jr.; Krystal L. Stravato; Michael Marino; Thomas MacDonald

all of the city of Cedar Knolls, state of NJ each individually if there be more than one named, its true and lawful attorney-in-fact to make, execute, seal, acknowledge and deliver, for and on its behalf as surety and as its act and deed, any and all undertakings, bonds, recognizances and other surety obligations, in pursuance of these presents and shall be as binding upon the Companies as if they have been duly signed by the president and attested by the secretary of the Companies in their own proper persons.

IN WITNESS WHEREOF, this Power of Attorney has been subscribed by an authorized officer or official of the Companies and the corporate seals of the Companies have been affixed thereto this 23rd day of March, 2017.



The Ohio Casualty Insurance Company
Liberty Mutual Insurance Company
West American Insurance Company

By: David M. Carey
David M. Carey, Assistant Secretary

STATE OF PENNSYLVANIA ss
COUNTY OF MONTGOMERY

On this 23rd day of March, 2017, before me personally appeared David M. Carey, who acknowledged himself to be the Assistant Secretary of Liberty Mutual Insurance Company, The Ohio Casualty Company, and West American Insurance Company, and that he, as such, being authorized so to do, execute the foregoing instrument for the purposes therein contained by signing on behalf of the corporations by himself as a duly authorized officer.

IN WITNESS WHEREOF, I have hereunto subscribed my name and affixed my notarial seal at King of Prussia, Pennsylvania, on the day and year first above written.



COMMONWEALTH OF PENNSYLVANIA
Notarial Seal
Teresa Pastella, Notary Public
Upper Merion Twp., Montgomery County
My Commission Expires March 20, 2021
Member, Pennsylvania Association of Notaries

By: Teresa Pastella
Teresa Pastella, Notary Public

This Power of Attorney is made and executed pursuant to and by authority of the following By-laws and Authorizations of The Ohio Casualty Insurance Company, Liberty Mutual Insurance Company, and West American Insurance Company which resolutions are now in full force and effect reading as follows:

ARTICLE IV – OFFICERS – Section 12. Power of Attorney. Any officer or other official of the Corporation authorized for that purpose in writing by the Chairman or the President, and subject to such limitation as the Chairman or the President may prescribe, shall appoint such attorneys-in-fact, as may be necessary to act in behalf of the Corporation to make, execute, seal, acknowledge and deliver as surety any and all undertakings, bonds, recognizances and other surety obligations. Such attorneys-in-fact, subject to the limitations set forth in their respective powers of attorney, shall have full power to bind the Corporation by their signature and execution of any such instruments and to attach thereto the seal of the Corporation. When so executed, such instruments shall be as binding as if signed by the President and attested to by the Secretary. Any power or authority granted to any representative or attorney-in-fact under the provisions of this article may be revoked at any time by the Board, the Chairman, the President or by the officer or officers granting such power or authority.

ARTICLE XIII – Execution of Contracts – SECTION 5. Surety Bonds and Undertakings. Any officer of the Company authorized for that purpose in writing by the chairman or the president, and subject to such limitations as the chairman or the president may prescribe, shall appoint such attorneys-in-fact, as may be necessary to act in behalf of the Company to make, execute, seal, acknowledge and deliver as surety any and all undertakings, bonds, recognizances and other surety obligations. Such attorneys-in-fact subject to the limitations set forth in their respective powers of attorney, shall have full power to bind the Company by their signature and execution of any such instruments and to attach thereto the seal of the Company. When so executed such instruments shall be as binding as if signed by the president and attested by the secretary.

Certificate of Designation – The President of the Company, acting pursuant to the Bylaws of the Company, authorizes David M. Carey, Assistant Secretary to appoint such attorneys-in-fact as may be necessary to act on behalf of the Company to make, execute, seal, acknowledge and deliver as surety any and all undertakings, bonds, recognizances and other surety obligations.

Authorization – By unanimous consent of the Company's Board of Directors, the Company consents that facsimile or mechanically reproduced signature of any assistant secretary of the Company, wherever appearing upon a certified copy of any power of attorney issued by the Company in connection with surety bonds, shall be valid and binding upon the Company with the same force and effect as though manually affixed.

I, Renee C. Llewellyn, the undersigned, Assistant Secretary, The Ohio Casualty Insurance Company, Liberty Mutual Insurance Company, and West American Insurance Company do hereby certify that the original power of attorney of which the foregoing is a full, true and correct copy of the Power of Attorney executed by said Companies, is in full force and effect and has not been revoked.

IN TESTIMONY WHEREOF, I have hereunto set my hand and affixed the seals of said Companies this 1st day of June, 2017.

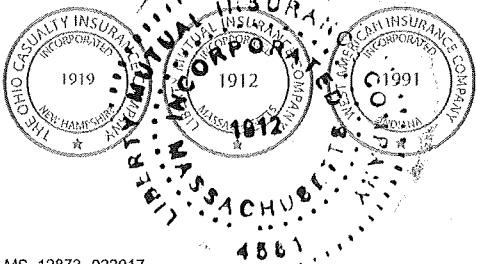

By: Renee C. Llewellyn
Renee C. Llewellyn, Assistant Secretary

Not valid for mortgage, note, loan, letter of credit, currency rate, interest rate or residual value guarantees.

To confirm the validity of this Power of Attorney call 1-610-832-8240 between 9:00 am and 4:30 pm EST on any business day.